

SERVICE MANUAL

SEGA

CONFIDENTIAL MISSION

DELUXE TYPE



IMPORTANT!

Before using this product, read this SERVICE MANUAL carefully to understand the contents stated herein. After reading this manual, be sure to keep it available nearby the product or somewhere convenient in order to be able to refer to it whenever necessary.

Manufactured in the UK by

SEGA



MANUFACTURING DIVISION (U.K.)

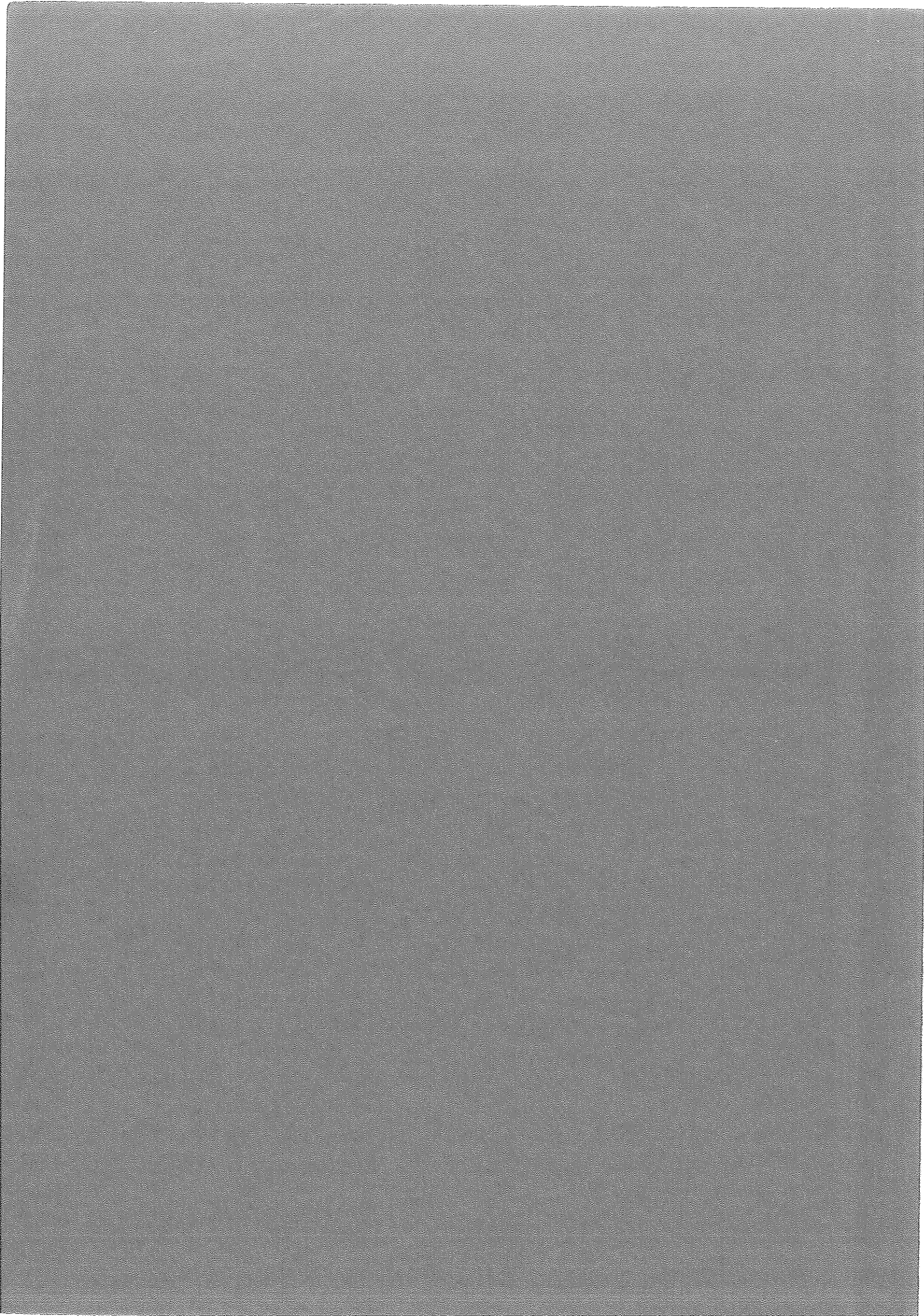

SAFETY WARNINGS

A

CH

D

BETRIEBSANLEITUNG FÜR VIDEO-GAMES

Diese Betriebsanleitung gehört zum Gerät und darf nicht entfernt werden !!

DK

BETJENINGSVEJLEDNING FOR VIDEO-GAMES

Denne betjeningsvejledning hører til apparatet og må ikke fjernes !!

E

INSTRUCCIONES DE SERVICIO PARA JUEGOS DE VÍDEO

¡¡Estas instrucciones de servicio son parte del aparato y no deben perderse!!

F

B

CH

INSTRUCTIONS DE SERVICE POUR JEUX VIDEO

Ces instructions de service font partie intégrante de l'appareil et doivent toujours l'accompagner !!

FIN

VIDEOPELIAUTOMAATTIEN KÄYTTÖOHJEET

Nämä käyttöohjeet kuuluvat laitteeseen eikä niitä saa poistaa!!

I

CH

ISTRUZIONI D'USO PER VIDEOGAMES

Questo manuale di istruzioni fa parte della macchina e non deve essere rimosso da essa!!

N

BRUKERVEILEDNING FOR VIDEO GAMES

Denne brukerveiledningen hører til maskinen og må ikke fjernes !!

NL

GEBRUIKSAANWIJZING VOOR VIDEOGAMES

Deze gebruiksaanwijzing hoort bij het toestel en mag niet verwijderd worden!!

P

INSTRUÇÕES DE SERVIÇO PARA OS JOGOS DE VÍDEO

Estas instruções fazem parte integral do aparelho e dele não podem ser retiradas!!

S

BRUKSANVISNING FÖR TV-SPEL

Denna bruksanvisning hör till apparaten och får inte avlägsnas!

GR

ΟΔΗΓΙΕΣ ΛΕΙΤΟΥΡΓΙΑΣ ΓΙΑ VIDEO-GAMES

Οι παρούσες οδηγίες λειτουργίας ανήκουν στη συσκευή και δεν επιτρέπεται να απομακρυνθούν!!

INHALTSVERZEICHNIS

1. **Vorwort**
 - EC-Konformitätserklärung

2. **Sicherheitshinweise**
 - 2.1. Begriffsdefinition
 - 2.2. Allgemeine Erläuterungen
 - 2.3. Grundsätzliche Sicherheitshinweise

3. **Geräteüberprüfung**
 - 3.1. Kontrolle nach Anlieferung

4. **Transport, Aufstellung und Inbetriebnahme**
 - 4.1. Wahl des Aufstellortes und Transport
 - 4.2. Aufstellung und Montage
 - 4.2.1. Video-Thekengerät
 - 4.2.2. Montagehinweise für Video-Standgerät und Video-Sitzgeräte
 - 4.2.2.1. Video-Standgerät, Lieferform
 - 4.2.2.2. Video-Sitzgerät, Lieferform
 - 4.3. Inbetriebnahme
 - 4.4. Einstellungen

5. **Inspektion, Wartung und Pflege**
 - 5.1. Allgemeine Hinweise
 - 5.2. Wartung
 - 5.3. Reinigen des Gehäuses und des äußeren Bildschirms

6. **Service**
 - 6.1. Allgemeine Hinweise
 - 6.2. Austausch defekter Beleuchtungskörper

7. **Ausserbetriebnahme**
 - 7.1. Allgemeine Hinweise
 - 7.2. Demontage
 - 7.3. Umstellung
 - 7.4. Entsorgung

8. **Warnhinweise**

1. Vorwort

Diese Betriebsanleitung gilt für Theken-, Stand- oder Sitz-Video-Spielautomaten. Ersatzteilnummern, Serviceanweisungen und Einstellungen siehe separat beiliegendes Original-Handbuch. Im Zweifelsfall insbesondere auch bei Verständnisschwierigkeiten sprachlicher oder sonstiger Art mit dem Original-Handbuch unbedingt die fachliche Hilfe Ihres Händlers in Anspruch nehmen!

Änderungen in diesem Handbuch durch Neuauflagen vorbehalten.

EC-Konformitätserklärung

Dieses Gerät entspricht den europäischen Sicherheitsrichtlinien und Standards. Es fällt nicht unter die Maschinenrichtlinie.

2. Sicherheitshinweise

2.1. Begriffsdefinition



WARNUNG !! Nichtbeachtung kann zu Personenschäden oder tödlichen Verletzungen führen.

2.2. Allgemeine Erläuterungen

Eingriffe in das Gerät nur durch Elektrofachkraft, sonst besteht Verletzungsgefahr sowie Gefahr einer dauerhaften Beschädigung. Die Folge wären teure Reparaturen, Austausch von Systemkomponenten, Erlöschen der Gewährleistungsansprüche.

Installation und Reparaturarbeiten nur durch Elektrofachkraft, Servicearbeiten nur durch eingewiesenes Personal. Der Eigentümer dieses Gerätes muß sicherstellen, daß alle Personen die mit der Aufstellung, Inbetriebnahme, Wartung, Reparatur und Instandhaltung des Gerätes zu tun haben, entsprechend qualifiziert sind und vor Arbeitsbeginn unbedingt die nötigen Sicherheitshinweise und dazugehörigen Kapitel des Handbuches gelesen und verstanden haben.

Betriebsanleitung unbedingt an sicherer Stelle für den späteren Gebrauch aufbewahren !

Bei unsachgemäßer Handhabung, bestimmungswidriger Verwendung und eigenmächtigen Umbauten wird keinerlei Haftung für Unfälle, Verletzungen und Beschädigungen übernommen! Eigenmächtige Umbauten und Veränderungen des Automaten sind aus Sicherheitsgründen ausdrücklich verboten.

Bei weiteren Fragen oder im Zweifelsfall Kontakt zu Ihrem Händler aufnehmen.

Die Sicherheitshinweise sind strikt einzuhalten ! Es geht um Ihre Sicherheit.

2.3. Grundsätzliche Sicherheitshinweise

Gerät darf nur betrieben werden, wenn Aufstellung vorschriftsmäßig und in Übereinstimmung mit dem Handbuch erfolgte.

Betriebsspannung und -frequenz des Gerätes muß mit der Netzspannung und -frequenz übereinstimmen. Elektrische Daten siehe Typenschild an der Geräterückseite. Gerät nur an ordnungsgemäß installierter, abgesicherter und geerdeter Netzsteckdose anschließen.

Aufstellung und Inbetriebnahme nur innerhalb geschlossener, trockener Räume! Gerät darf nur gewerblich genutzt werden!

Beschädigte oder fehlende Warnhinweise am Gerät sind sofort zu ersetzen.



WARNUNG !! Implosionsgefahr der Bildröhre und Neonröhren

Aufstellung nur auf stabilem, tragfähigem Untergrund, ggf. befestigen. Umstürzendes Gerät kann die Implosion der Bild- oder Neonröhren zur Folge haben. Umherfliegende Glassplitter können zu schwersten Verletzungen führen.



WARNUNG !! Gefahr durch elektrischen Schlag

Vor Öffnen des Gerätes IMMER den Netzstecker aus der Steckdose ziehen! Netzstecker niemals mit nassen Händen berühren. Geräte-Rückwand darf nur von Elektrofachkraft geöffnet werden. Lebensgefährliche, berührbare Hochspannungen im Inneren des Gerätes, die auch nach Ziehen des Netzsteckers anstehen. Nichtbeachtung kann zu Tod oder schweren Verletzungen führen.



WARNUNG !! Brandgefahr

Sicherungen nur gegen vorgeschriebene Sicherungen ersetzen. Lüftungsschlitze des Spielautomaten niemals blockieren. Umgebungstemperatur darf 40°C nicht überschreiten. Netzstromkreis und Zuleitungen nicht überlasten.

Bei Defekt sofort den Netzstecker aus der Steckdose ziehen und Reparatur nur von Elektrofachkraft durchführen lassen. Nur am Netzstecker, nicht am Kabel ziehen.

Steckverbindungen im Inneren des Gerätes, im Fall einer Fehlersuche, niemals unter Spannung abziehen oder aufstecken. Reparatur grundsätzlich im spannungslosen Zustand!

Nur Original-Ersatzteile verwenden.

Nichtbefolgung der oben genannten Punkte kann lebensgefährlich sein !

3. Geräteüberprüfung

3.1. Kontrolle nach Anlieferung

Gerät direkt bei der Anlieferung auf Transportschäden untersuchen. Sichtbare Beschädigungen auf den Speditionspapieren des anliefernden Spediteurs vermerken oder unmittelbar nach Erhalt der Ware melden, um Ihre Ansprüche zu sichern.

Gerät öffnen und sämtliche Baugruppen und Steckverbinder auf ordnungsgemäßen Sitz prüfen.

Beigepacktes Montagmaterial aus dem Geräteinneren oder der Kassenbox entnehmen.

Entspricht der mitgelieferte Netzstecker nicht der landesüblich vorgeschriebenen Norm, passenden Netzstecker an das Netzkabel anschließen.



WARNUNG !! Gefahr durch elektrischen Schlag

Anschluß des Netzsteckers nur durch Elektrofachkraft. Bei Nichtbeachtung gefährden Sie sich und andere!

Falls vorhanden, separates Kopfteil oder Sitzeinheit der Verpackung entnehmen. Montage dieser Teile erst am Aufstellplatz, sonst Beschädigung beim Transport.

4. Transport, Aufstellung und Inbetriebnahme

4.1. Wahl des Aufstellortes und Transport

Aufstellung und Inbetriebnahme nur innerhalb geschlossener, trockener Räume! Aufstellung

im Freien oder in feuchten / nassen Räumen ist strikt untersagt. Eindringende Feuchtigkeit kann zu Unfällen durch elektrischen Schlag oder Fehlern innerhalb des Gerätes führen.

Transportwege und -möglichkeiten am Aufstellplatz vor Transport prüfen. Bei Geräten mit Transportrollen besondere Vorsicht bei abschüssigem Boden.

Gerät nur mit einer ausreichenden Anzahl Personen bewegen. Vorsicht bei tiefer hängenden Beleuchtungskörpern.

Gerät auf ebenem, tragfähigem Untergrund aufstellen. Lüftungsöffnungen auf der Geräterückseite nicht behindern. Ausreichenden Wandabstand (min. 10 cm) einhalten.

Gerät nicht plazieren in der Nähe von:

- a) lebensrettenden Einrichtungen, wie z. B.:
 - Notausgängen,
 - Feuerlöschern etc.
- b) Behältern mit leicht entzündlichen Stoffen, Wasser oder Chemikalien,
- c) Wärmequellen, wie z. B.:
 - Heizkörpern
 - Öffnungen von Klimaanlage,
 - Schaufenstern mit direkter Sonneneinstrahlung etc.

Gerät keiner Belastung aussetzen, die zu Funktionstörung oder Defekt führt, wie z. B.:

- starker Vibration,
- extremer Staub- oder Schmutzbelastung,
- direkter Sonneneinstrahlung oder Hitze,
- Regen oder Feuchtigkeit,
- starker Magnetismus oder Funkwellen.

Direkt am Geräteaufstellplatz muß eine ordnungsgemäß installierte, geerdete, abgesicherte Netzsteckdose vorhanden sein.

Den Stromkreis, an dem das Gerät angeschlossen wird, nicht überlasten.

Netzkabel derart verlegen, daß niemand darüber stolpert. Nichtbeachtung kann zu schweren Verletzungen oder zur Beschädigung des Netzkabels führen.

Netzkabel nicht scharf knicken oder schwere Gegenstände darauf stellen, sonst Beschädigung der Isolation, mögliche Folge, berührbare Netzspannung, Kurzschluß und dadurch bedingte Feuer.

4.2. Aufstellung und Montage des Gerätes

Gerät plazieren. Netzstecker noch nicht einstecken, erst nach abgeschlossener Aufstellung!



WARNUNG !! Implosionsgefahr der Bildröhre und Neonröhren

Unbedingt die Sicherheitshinweise in Kapitel 2.3 beachten.

4.2.1. Video-Thekengeräte werden komplett montiert geliefert. Keine weiteren Montagen notwendig. Für sicheren Standplatz sorgen!

4.2.2. Montagehinweise Video-Standgerät und Video-Sitzgeräte

Falls vorhanden, separate Zubehörteile sicher mit den im Beipack befindlichen Schrauben am Gerät befestigen. Kopfteil während der Montage von mindestens 2 Helfern sichern lassen, Steighilfe, z. B. Leiter oder Tritt benutzen. Falls vorhanden, Steckverbindungen der Zubehörteile aufstecken.

Schutzleiterverbindungen sicher herstellen.

Montagehinweise siehe Original-Handbuch.

Im Zweifelsfall unbedingt die fachliche Hilfe Ihres Händlers in Anspruch nehmen!

4.2.2.1. Video-Standgerät, mögliche Lieferformen:

- a) komplett montiert und / oder
- b) mit separat beige-packtem Kopfteil (beleuchtet oder unbeleuchtet) und / oder
- c) mit separat beige-packter Bedienungseinheit

4.2.2.2. Video-Sitzgerät, mögliche Lieferformen:

- a-c) wie Video-Standgerät und / oder zusätzlich
- d) mit separat beige-packter Sitzeinheit

4.3. Inbetriebnahme

Falls vorhanden, mit den höhenverstellbaren Fußschrauben das Gerät genau nivellieren. Das Gerät muß absolut fest auf dem Untergrund stehen. Bei glatten Fußböden Gummikappen unter den Gerätefüßen benutzen.

Alle Baugruppen und Steckverbinder auf festen Sitz prüfen. Besonders Schutzleiterverbindungen aller berührbaren Metallteile von Elektrofachkraft auf festen Sitz prüfen lassen!

Hauptschalter ausschalten. Netzstecker erst nach Sicherstellung aller vorgenannter Punkte einstecken.

Hauptschalter einschalten. Bei unnormalem Geräusch, Rauch oder ungewöhnlichem Geruch nach dem Einschalten, sofort den Netzstecker aus der Steckdose zu ziehen und Elektrofachkraft zu Rate ziehen. Im Zweifelsfall unbedingt Ihren Händler kontaktieren.



WARNUNG !! Brandgefahr

Auf keinen Fall das Gerät in diesem Zustand weiter betreiben.

4.4. Einstellungen

Programm- bzw. modellbedingte Einstellungen dem beiliegendem Original-Handbuch entnehmen.



WARNUNG !! Gefahr durch elektrischen Schlag

Unbedingt die Sicherheitshinweise in Kapitel 2 beachten.

Im Zweifelsfall unbedingt die fachliche Hilfe Ihres Händlers in Anspruch nehmen!

5. Inspektion, Wartung und Pflege

5.1. Allgemeine Hinweise



WARNUNG !! Gefahr durch elektrischen Schlag

Unbedingt die Sicherheitshinweise in Kapitel 2 beachten.

Zustand des Netzkabels regelmäßig prüfen. Bei beschädigtem Kabel oder Netzstecker, Gerät sofort außer Betrieb nehmen und durch Elektrofachkraft reparieren lassen.

Unbedingt die Warnhinweise auf Vorhandensein und Lesbarkeit überprüfen, ggf. ersetzen (siehe Kapitel 8).

5.2. Wartung

Das Gerät selbst ist wartungsfrei.

5.3. Reinigen des Gehäuses und des äußeren Bildschirms

1. Gerät ausschalten und Netzstecker ziehen!
2. Gehäuse und äußeren Bildschirm mit weichem, feuchtem (nicht nassem) Tuch und milden Reinigungsmittel reinigen (keine Lösungsmittel-, säure- oder scheuermittelhaltigen Reiniger verwenden).

6. Service

6.1. Allgemeine Hinweise



WARNUNG !! Gefahr durch elektrischen Schlag

Unbedingt die Sicherheitshinweise in Kapitel 2 beachten.

Bei Defekt sofort den Netzstecker aus der Steckdose ziehen und Reparatur nur von Elektrofachkraft durchführen lassen. Servicehinweise siehe Original-Handbuch.

Im Zweifelsfall unbedingt die fachliche Hilfe Ihres Händlers in Anspruch nehmen!

6.2. Austausch defekter Beleuchtungskörper

1. Gerät ausschalten und Netzstecker ziehen!
2. Vorsicht, Beleuchtungskörper kann heiß sein!
3. Beleuchtungskörper nur durch vorgeschriebene Teile austauschen. Servicehinweise siehe Original-Handbuch.

7. Ausserbetriebnahme

7.1. Allgemeine Hinweise



WARNUNG !! Gefahr durch elektrischen Schlag

Unbedingt die Sicherheitshinweise in Kapitel 2 beachten.

7.2. Demontage

Netzstecker ziehen. Alle im Kapitel 4.2. beschriebenen Zubehörteile in umgekehrter Reihenfolge demontieren. Kopfteil während der Demontage von min. 2 Helfern sichern lassen.

7.3. Umstellung

Umtransport und Wiederinbetriebnahme wie im Kapitel 4 beschrieben durchführen.

7.4. Entsorgung

Durch zugelassenes Fachunternehmen entsorgen lassen.

8. Warnhinweise

Warnhinweise, in Text oder Bild, als Aufkleber, Aufdruck und / oder in Form dieser Betriebsanleitung unterliegen natürlichem Verschleiß. Der Betreiber trägt die Verantwortung, daß sie vorhanden und stets lesbar sind.

Beschädigte oder fehlende Warnhinweise sind sofort zu ersetzen. Kontaktieren Sie im Bedarfsfall Ihren Händler.

Betriebsanleitung unbedingt an sicherer Stelle für den späteren Gebrauch aufbewahren !

INDHOLDSFORTEGNELSE

1. **Forord**
EC-konformitetserklæring
2. **Sikkerhedshenvisninger**
 - 2.1. Begrebsdefinition
 - 2.2. Generelle bestemmelser
 - 2.3. Principielle sikkerhedshenvisninger
3. **Apparatcheck**
 - 3.1. Kontrol ved levering
4. **Transport, opstilling og idrifttagning**
 - 4.1. Valg af opstillingssted og transport
 - 4.2. Opstilling og montering
 - 4.2.1. Videoapparat, bordmodel
 - 4.2.2. Monteringshenvisninger for videoapparat med stående og siddende betjening
 - 4.2.2.1. Videoapparat til stående betjening, leveringsform
 - 4.2.2.2. Videoapparat til siddende betjening, leveringsform
 - 4.3. Idrifttagning
 - 4.4. Indstillinger
5. **Inspektion, vedligeholdelse og pleje**
 - 5.1. Generelle henvisninger
 - 5.2. Vedligeholdelse
 - 5.3. Rengøring af kabinet og ydre billedskærm
6. **Service**
 - 6.1. Generelle henvisninger
 - 6.2. Udskiftning af defekte belysningsselementer
7. **Demontering**
 - 7.1. Generelle henvisninger
 - 7.2. Demontering
 - 7.3. Genopstilling
 - 7.4. Destruering
8. **Advarselshenvisninger**

1. Forord

Denne betjeningsvejledning gælder for video-spilleautomater som bordmodel, eller modeller til stående eller siddende betjening. Reservedelsnumre, servicehenvisninger og indstillinger, se den separat vedlagte originalhåndbog. I tvivlstilfælde især ved forståelsesvanskeligheder af sproglig eller anden art vedrørende originalhåndbogen kontakt ubetinget forhandleren for at opnå faglig hjælp!

Med forbehold mod ændringer i denne håndbog ved nyoplag.

EC-konformitetserklæring

Dette apparat overholder de europæiske sikkerhedsretningslinier og standarder. Det falder ikke ind under retningslinier for maskiner.

2. Sikkerhedshenvisninger

2.1. Begrebsdefinition



ADVARSEL !! Ignorering kan føre til personskader eller livsfarlige kvæstelser.

2.2. Generelle bestemmelser

Indgreb i apparatet må kun foretages af elektrofagfolk, ellers består der fare for kvæstelser samt fare for blivende skader. Følgen heraf er dyre reparationer, udskiftning af systemkomponenter, tab af garantirettigheder.

Installation og reparationsarbejder må kun foretages af elektrofagfolk, servicearbejder kun af instrueret personale. Ejeren af dette apparat skal sørge for, at alle personer, der er beskæftiget med opstilling, idrifttagning, vedligeholdelse, reparation og service, er tilsvarende kvalificeret og at de før arbejdets påbegyndelse ubetinget har læst og forstået de nødvendige sikkerhedshenvisninger og dertil hørende kapitler i håndbogen.

Betjeningsvejledningen skal ubetinget opbevares på et sikkert sted for senere benyttelse!

Ved usagmæssig betjening, ikke formålsbestemt anvendelse og egenmægtige ombygninger overtages ingen garanti for uheld, tilskadekomst og beskadigelser! Egenmægtige ombygninger og ændringer af automaten er af sikkerhedsmæssige grunde udtrykkeligt forbudt.

Ved yderligere spørgsmål eller i tvivlstilfælde optag kontakt med Deres forhandler.

Sikkerhedshenvisningerne skal ubetinget overholdes ! Det gælder Deres sikkerhed.

2.3. Principielle sikkerhedshenvisninger

Apparatet må kun benyttes, hvis opstillingen er udført forskriftsmæssigt og i overensstemmelse med håndbogen.

Driftsspænding og -frekvens for apparatet skal være i overensstemmelse med den lokale netspænding og -frekvens. Vedrørende elektriske data se typeskiltet på apparatets bagside. Apparatet må kun tilsluttes til en forskriftsmæssig installeret, afsikret og jordforbundet netstikdåse.

Opstilling og idrifttagning er kun tilladt i lukkede, tørre lokaler! Apparatet må kun anvendes erhvervsmæssigt!

Beskadigede eller manglende advarselshenvisninger på apparatet skal omgående erstattes med nye.



ADVARSEL !! Implosionsfare for billedrør og neonrør

Opstilling må kun foretages på et stabilt, bæredygtigt underlag, i givet fald forstærkes dette. Hvis apparatet vælter kan dette have implosion af billed- og neonrør til følge. Omkringflyvende glassplinter kan medføre de alvorligste kvæstelser



ADVARSEL !! Fare for elektriske stød

Før åbning af apparatet skal netstikket ALTID trækkes ud af stikdåsen! Berør aldrig netstikket med våde hænder. Apparatets bagvæg må kun åbnes af elektrofagfolk. Livsfarlige, berørbare højspændinger inde i apparatet, der også er tilstede efter af netstikket er trukket. Ignorering kan medføre død eller svære kvæstelser.



ADVARSEL !! Brandfare

Sikringer må kun udskiftes med foreskrevne sikringer. Udluftningsslidser på spilleautomaten må aldrig blokeres. Omgivelsestemperaturen må ikke overskride 40°C. Netinstallation og tilledninger må ikke overbelastes.

Ved en defekt trækkes netstikket omgående ud af stikdåsen og en reparation må kun udføres af elektrofagfolk. Træk kun i netstikket, ikke i ledningen.

Stikforbindelser inde i apparatet må, ved en eventuel fejlsøgning, aldrig skilles ad eller forbindes under spænding. Reparationer må kun foretages i spændingsløs tilstand!

Anvend kun originale reservedele.

Ignorering af de ovenfor nævnte punkter kan være livsfarligt !

3. Apparatcheck

3.1. Kontrol ved levering

Apparatet undersøges omgående for transportskader ved levering. For at sikre Deres erstatningskrav, skal synlige beskadigelser noteres på speditionspapirerne fra speditøren eller meldes umiddelbart efter modtagelse af varen.

Apparatet åbnes og samtlige monteringsenheder og stikforbindelser kontrolleres for forskriftsmæssig og korrekt montering.

Vedlagte monteringsmateriale tages ud af apparatet eller kasseboksen.

Svarer det leverede netstik ikke til den lokalt foreskrevne norm, monteres et passende netstik på netledningen.



ADVARSEL !! Fare for elektriske stød

Tilslutning af netstikket må kun foretages af elektrofagfolk. Ved ignorering består fare for Dem og andre!

Hvis forhåndenværende, tages den separate overdel eller siddeenhed ud af emballagen. For at undgå transportskader, foretages montering af disse dele først på opstillingsstedet.

4. Transport, opstilling og idrifttagning

4.1. Valg af opstillingssted og transport

Opstilling og idrifttagning kun i lukkede, tørre lokaler! Opstilling i det fri eller i fugtige/våde rum er strengt forbudt. Indtrængende fugtighed kan føre til uheld gennem elektriske stød

eller fejl i apparatets indre. Undgå direkte sollys.

Transportveje og -muligheder på opstillingsstedet kontrolleres før transporten. Ved apparater med transportruller udvises særlig forsigtighed ved skrånende gulve.

Apparatet må kun bevæges med et tilstrækkeligt antal personer. Pas på lavthængende belysning.

Apparatet opstilles på en jævn, bæredygtig undergrund. Udluftningsåbningerne på bagsiden af apparatet må ikke tildækkes. Tilstrækkelig vægafstand (min. 10 cm.) skal overholdes.

Apparatet må ikke placeres i nærheden af:

- a) livsreddende indretninger, som f.eks.
 - nødudgange,
 - ildslukkere etc.
- b) beholdere med letantændelige stoffer, vand eller kemikalier.
- c) varmekilder, som f.eks.
 - radiatorer
 - åbninger fra klimaanlæg,
 - udstillingsvinduer med direkte sollys etc.

Apparatet må ikke udsættes for belastninger, der fører til funktionsforstyrrelser eller defekter som f.eks.

- stærk vibration,
- ekstrem støv- eller smudsbelastning,
- direkte sollys eller varme,
- regn eller fugtighed,
- stærke magnetfelter eller radiobølger.

Direkte på opstillingsstedet for apparatet skal der findes en korrekt installeret, jordforbundet, afsikret netstikdåse.

Netinstallationen, til hvilket apparatet er tilsluttet, må ikke overbelastes.

Netledningen forlægges således, at der ikke opstår snubelfare. Ignorering kan føre til alvorlige kvæstelser eller til beskadigelse af netledningen.

Undgå skarpe knæk på netledningen og anbring ikke denne under tunge genstande, da der ellers er fare for beskadigelse af isolationen. Mulige følger er fritliggende netspænding, kortslutning og deraf betinget ildebrand.

4.2. Opstilling og montering

Apparatet placeres på opstillingsstedet. Netstikket må først anbringes i netstikdåsen efter afsluttet opstilling!



ADVARSEL !! Implosionsfare for billedrør og neonrør

Overhold ubetinget sikkerhedshenvisningerne i kapitel 2.3.

4.2.1. Videoapparat, bordmodeller leveres komplet monteret. Ingen yderligere montering nødvendig. Sørg for en sikker placering!

4.2.2. Monteringshenvisninger for videoapparat til stående og siddende betjening

Hvis forhåndenværende, befæstiges separate tilbehørsdele sikkert på apparatet med de vedlagte skruer. Overdelen sikres under monteringen af mindst 2 hjælpere, benyt evt. stige eller taburet. Hvis forhåndenværende, tilsluttes stikforbindelserne på tilbehørsdelene.

Stelforbindelserne laves omhyggeligt.

Monteringshenvisninger, se originalhåndbogen.

I tvivlstilfælde opsøges ubetinget Deres forhandler for at opnå faglig hjælp!

4.2.2.1. Videoapparat til stående betjening, mulige leveringsformer:

- a) komplet monteret og/eller
- b) med separat vedlagt overdel (belyst eller ubelyst) og/eller
- c) med separat vedlagt betjeningsenhed

4.2.2.2. Videoapparat til siddende betjening, mulige leveringsformer:

- a-c) som videoapparat til stående betjening og/eller yderligere
- d) med separat vedlagt siddeenhed.

4.3. Idrifttagning

Hvis forhåndenværende, nivelleres apparatet nøjagtigt med de højdejusterbare apparatfødder. Apparatet skal stå absolut fast på underlaget. Ved glatte gulve benyttes gummikapper på apparatfødderne.

Alle monteringsenheder og stikforbindelser kontrolleres for korrekt samling. Især skal alle stelforbindelser til alle berørbare metaldele kontrolleres af en elektrofagmand for korrekt forbindelse!

Hovedafbryderen udkobles. Netstikket stikkes først i efter afslutning af alle forudgående punkter.

Hovedafbryderen indkobles. Ved unormal støj, røg eller usædvanlig lugt efter indkoblingen, trækkes netstikket omgående ud af stikdåsen og en elektrofagmand spørges til råds. I tvivlstilfælde kontakt ubetinget Deres forhandler.



ADVARSEL !! Brandfare

Det defekte apparat må under ingen omstændigheder benyttes i denne tilstand.

4.4. Indstillinger

Program - hhv. modelbetingede indstillinger findes i den vedlagte originalhåndbog.



ADVARSEL !! Fare for elektriske stød

Overhold ubetinget sikkerhedshenvisningerne i kapitel 2.

I tvivlstilfælde opsøges ubetinget Deres forhandler for at opnå faglig hjælp!

5. Inspektion, vedligeholdelse og pleje

5.1. Generelle henvisninger



ADVARSEL !! Fare for elektriske stød

Overhold ubetinget sikkerhedshenvisningerne i kapitel 2.

Netledningens tilstand kontrolleres med jævne mellemrum. Er ledningen eller netstikket beskadiget skal apparatet omgående tages ud af drift og repareres af en elektrofagmand.

Kontroller ubetinget om advarselshenvisningerne er anbragt på apparatet og om de er læsbare, hvis ikke skal de udskiftes (se kapitel 8).

5.2. Vedligeholdelse

Apparatet er vedligeholdelsesfrit.

5.3. Rengøring af kabinet og ydre billedskærm

1. Apparatet slukkes og netstikket trækkes ud!
2. Kabinettet og den ydre billedskærm rengøres med en blød, fugtig (ikke våd) klud og et mildt rensmiddel (anvend ikke opløsningsmiddel-, syre- eller skuremiddelholdige rensmidler).

6. Service

6.1. Generelle henvisninger



ADVARSEL !! Fare for elektriske stød

Overhold ubetinget sikkerhedshenvisningerne i kapitel 2.

Ved en defekt trækkes netstikket omgående ud af stikdåsen og en påfølgende reparation må kun udføres af en elektrofagmand. Vedrørende servicehenvisninger, se originalhåndbogen.

I tvivlstilfælde opsøges ubetinget Deres forhandler for at opnå faglig hjælp!

6.2. Udskiftning af defekte belysningselementer

1. Sluk for apparatet og træk netstikket ud!
2. Pas på, belysningselementerne kan være varme!
3. Udskift kun belysningselementer med foreskrevne dele. Vedrørende servicehenvisninger, se originalhåndbogen.

7. Demontering

7.1. Generelle henvisninger



ADVARSEL !! Fare for elektriske stød

Overhold ubetinget sikkerhedshenvisningerne i kapitel 2.

7.2. Demontering

Netstikket trækkes ud. Alle i kapitel 4.2 beskrevne tilbehørsdele demonteres i omvendt rækkefølge. Overdelen sikres af min. 2 hjælpere under demonteringen.

7.3. Genopstilling

Forny transport, opstilling og idrifttagning gennemføres som beskrevet i kapitel 4.

7.4. Destruering

Destruering må kun gennemføres af et autoriseret firma.

8. Advarselshenvisninger

Advarselshenvisninger, i tekst og/eller billede, som klæbemærkat, påtryk og/eller i form af denne betjeningsvejledning er udsat for et naturligt slid. Ejeren bærer ansvaret for at de altid er forhåndenværende og læsbare.

Beskadigede eller manglende advarselshenvisninger skal omgående erstattes med nye. Kontakt Deres forhandler ved behov.

Betjeningsvejledningen skal til senere brug ubetinget opbevares et sikkert sted!

CONTENIDO

1. **Prefacio**
Declaración de conformidad de la CEE
2. **Avisos de seguridad**
 - 2.1. Definición
 - 2.2. Aclaraciones generales
 - 2.3. Avisos básicos de seguridad
3. **Control del aparato**
 - 3.1. Control después de la entrega
4. **Transporte, instalación y puesta en servicio**
 - 4.1. Elección del lugar de montaje y transporte
 - 4.2. Instalación y montaje del aparato
 - 4.2.1. Los aparatos de vídeo para mostrador
 - 4.2.2. Avisos de montaje Aparato de vídeo de pie y aparatos con asiento
 - 4.2.2.1. Aparato de vídeo de pie, suministro
 - 4.2.2.2. Aparato de vídeo con asiento suministro
 - 4.3. Puesta en servicio
 - 4.4. Ajustes
5. **Inspección, mantenimiento y cuidado**
 - 5.1. Avisos generales
 - 5.2. Mantenimiento
 - 5.3. Limpieza del cuerpo y de la pantalla exterior
6. **Servicio**
 - 6.1. Avisos generales
 - 6.2. Cambio de las lámparas defectuosas
7. **Puesta fuera de servicio**
 - 7.1. Avisos generales
 - 7.2. Desmontaje
 - 7.3. Transporte
 - 7.4. Gestión residual
8. **Avisos de peligro**

1. Prefacio

Estas instrucciones de servicio se refieren a las máquinas recreativas de mostrador, de pie o de asiento. Para números de piezas de repuesto, avisos de servicio y ajustes, véase el manual original adjunto por separado. En caso de duda, particularmente en dificultades idiomáticas o de cualquier otra índole con el manual original, ¡recurra necesariamente a la ayuda técnica de su distribuidor!

Reservadas las modificaciones a este manual en nuevas ediciones.

Declaración de conformidad de la CEE

Este aparato satisface las directrices y los estándares de seguridad estipulados por la CEE. No recae bajo la denominación de directriz para maquinarias.

2. Avisos de seguridad

2.1. Definición



¡¡ATENCIÓN !! El incumplimiento puede llegar a provocar daños personales o lesiones mortales.

2.2. Aclaraciones generales

Intervenciones en el aparato sólo por personal eléctrico especializado, pues de lo contrario existe riesgo de lesiones personales así como de un deterioro permanente del aparato. Resultado de ello serían trabajos costosos de reparación, cambio de componentes del sistema, caducidad de los derechos de garantía.

Instalación y trabajos de reparación sólo por personal eléctrico especializado, trabajos de servicio sólo por personal instruido. El propietario del aparato tiene que asegurarse de que todas las personas que tengan que ver con la instalación, puesta en servicio, mantenimiento y reparación del aparato, estén cualificadas para ello y de que antes de comenzar con los trabajos hayan leído y comprendido los avisos necesarios de seguridad y el capítulo correspondiente del manual.

¡Guardar las instrucciones de servicio en un lugar seguro para su uso posterior!

¡No se asume ninguna clase de garantía por accidentes, lesiones y daños que devengan de un manejo inadecuado, un uso no autorizado y a transformaciones personales del aparato! Por motivos de seguridad, se prohíbe terminantemente realizar modificaciones y transformaciones personales en el aparato.

Contacte con su distribuidor para otras preguntas o en caso de duda.

¡Tienen que cumplirse estrictamente los avisos de seguridad! Por su propia seguridad.

2.3. Avisos básicos de seguridad

El aparato debe ponerse en servicio sólo, si se realizó la instalación correctamente conforme al manual.

La tensión y frecuencia de servicio del aparato tiene que coincidir con la tensión y la frecuencia de la red. Para los datos eléctricos, véase la placa de características ubicada en la parte posterior del aparato. Conectar el aparato solamente a un enchufe correctamente instalado, con cortacircuito y con toma de tierra.

¡Instalación y puesta en servicio únicamente dentro de locales cerrados y secos! ¡El aparato sólo debe usarse de forma comercial!

Los avisos de peligro deteriorados o ausentes en el aparato han de reemplazarse inmediatamente.



¡¡ATENCIÓN !! Peligro de implosión de los tubos de imagen y de neón
Instalación únicamente sobre una superficie estable y robusta, sujetar caso necesario. La caída del aparato puede tener como consecuencia la implosión de los tubos de imagen y de neón. Los cascotes de vidrio despedidos pueden provocar lesiones graves.



¡¡ATENCIÓN !! Peligro de sacudidas eléctricas

Antes de abrir el aparato ¡Saque SIEMPRE el enchufe de la toma de red! La pared trasera del aparato sólo ha de abrirla un electricista especializado. En el interior del aparato existen altas tensiones peligrosas al contacto, que se forman incluso después de desconectar el enchufe. Su incumplimiento puede provocar lesiones graves o la muerte.



¡¡ATENCIÓN !! Peligro de incendio

Cambie los fusibles quemados sólo por los fusibles prescritos. No obstruya nunca las rejillas de ventilación de las máquinas recreativas. No sobrepase la temperatura ambiente de 40°C. No sobrecargue el circuito eléctrico ni las líneas de alimentación.

En caso de defecto, saque inmediatamente el enchufe de la toma de red y encargue su reparación solamente a un técnico electricista. Tire solamente del enchufe y no del cable.

Al buscar fallos, no saque ni meta nunca las conexiones de enchufe existentes bajo tensión dentro del aparato. Por regla general, ¡todos los trabajos de reparación en estado sin tensión!

Utilice solamente piezas originales de repuesto.

¡El incumplimiento de los puntos arriba mencionados puede generar un peligro de muerte!

3. Control del aparato

3.1. Control después de la entrega

Controle los daños de transporte del aparato directamente después de la entrega. Para asegurar sus derechos, anote los daños visibles en los documentos de expedición de la agencia de transportes o notifique inmediatamente después de la recepción de la mercancía.

Abra el aparato y controle la posición correcta de todos los componentes y conexiones de enchufe.

Saque del interior del aparato o de la caja el material de montaje empaquetado.

Si el enchufe de red suministrado no cumple la norma prescrita local, conecte un enchufe adecuado al cable de alimentación.



¡¡ATENCIÓN !! Peligro de sacudidas eléctricas

Conexión del enchufe de red solamente por un técnico electricista.
¡Su incumplimiento pone en peligro a usted mismo y a otras personas!

Si disponibles, sacar del embalaje la pieza superior separada o la unidad con asiento. Montaje de estas piezas sólo en el lugar de instalación, de lo contrario deterioros en el transporte.

4. Transporte, instalación y puesta en servicio

4.1. Elección del lugar de montaje y transporte

¡Instalación y puesta en servicio únicamente dentro de locales cerrados y secos!. Se prohíbe estrictamente la instalación al aire libre o en locales húmedos. La humedad penetrante puede provocar accidentes causados por sacudidas eléctricas o por fallos dentro del aparato. Evite una exposición directa a los rayos del sol.

Antes del transporte, controlar en el lugar de instalación las vías y posibilidades de transporte. En suelos inclinados, mover con mucha precaución los aparatos provistos de rodillos para el transporte.

Mover el aparato junto con una cantidad suficiente de personas. Cuidado con las lámparas que cuelgan muy bajas.

Colocar el aparato sobre una superficie plana y robusta. No obstruir los orificios de ventilación situados en la parte trasera del aparato. Mantener una separación suficiente de la pared (10 cm mín.).

No colocar el aparato cerca de:

- a) instalaciones de salvamento, como p. ej.
 - salidas de emergencia,
 - extintores, etc.
- b) recipientes con sustancias fácilmente inflamables, agua o productos químicos,
- c) fuentes de calor, como p. ej.
 - calefacciones
 - aberturas de acondicionadores de aire
 - escaparates con irradiaciones directas del sol etc.

No someter el aparato a cargas que provoquen a una avería funcional o a defectos, como p. ej.

- fuertes vibraciones,
- acumulación extrema de polvo o suciedad,
- exposición directa a los rayos del sol o calor,
- lluvia o humedad,
- fuerte magnetismo o radioondas.

Tiene que existir una caja de enchufe instalada correctamente, con toma de tierra y de cortacircuito directamente en el lugar de montaje del aparato.

No sobrecargar el circuito eléctrico al que se acopla el aparato.

Tender el cable de alimentación de tal modo que nadie se tropiece con él. Su incumplimiento puede provocar lesiones o deteriorar el cable de alimentación.

No doblar fuertemente el cable de alimentación ni colocar sobre él objetos pesados, pues puede deteriorarse el aislamiento, teniendo como consecuencia una exposición libre de la tensión de red, un cortocircuito y un posible incendio.

4.2. Instalación y montaje del aparato

¡Colocar el aparato, no meter todavía el enchufe en la red, sólo después de concluir la instalación!.



¡¡ATENCIÓN !! Peligro de implosión de los tubos de imagen y de neón

Cumplir necesariamente los avisos de seguridad del capítulo 2.3.

4.2.1. Los aparatos de vídeo para mostrador se entregan completamente montados. No es necesario otro montaje. ¡Procurar un lugar seguro estático!

4.2.2. Avisos de montaje Aparato de vídeo de pie y aparatos con asiento

Si disponibles, sujetar las piezas accesorias separadas con seguridad al aparato con los tornillos que se encuentran en el paquete secundario. Asegurar la pieza superior durante el montaje con dos ayudantes como mínimo, usar por ejemplo escalerillas y otras ayudas. Enchufar las conexiones de enchufe de las piezas accesorias, si disponibles.

Establecer las conexiones seguras de toma de tierra.

Para los avisos de montaje véase el manual original.

¡En caso de duda, recurra necesariamente a la ayuda técnica de su distribuidor!

4.2.2.1. Aparato de vídeo de pie, suministros posibles:

- a) montado completamente y/o
- b) con pieza superior embalada por separado (iluminada o no) y /o
- c) con unidad de control embalada por separado.

4.2.2.2. Aparato de vídeo con asiento suministros posibles:

- a-c) como el aparato de pie y/o adicional
- d) con unidad de asiento embalada por separado.

4.3. Puesta en servicio

Si disponible, nivelar exactamente el aparato con los tornillos de pata regulables en altura. El aparato tiene que estar sobre el fundamento completamente fijo. En suelos resbaladizos utilizar las caperuzas de goma para las patas.

Controlar la posición correcta de los componentes y de las conexiones de enchufe. ¡Encargar a un electricista especializado controlar especialmente la correcta posición de todos los cables de tierra de todas las piezas metálicas libres!.

Desconectar el interruptor principal. Conectar el enchufe de red sólo después de controlar todos los puntos anteriormente mencionados.

Conectar el interruptor principal. Si después de conectar, escuchara un ruido anormal, humo o olores raros, sacar inmediatamente el enchufe de la toma de red y solicitar el consejo de un electricista especializado. En caso de duda, contacte necesariamente con su distribuidor.



¡¡ATENCIÓN !! Peligro de incendio

No ponga en funcionamiento en ningún caso el aparato averiado.

4.4. Ajustes

Leer los ajustes conformes al modelo y/o al programa en el manual original adjunto.



¡¡ATENCIÓN !! Peligro de sacudidas eléctricas

Cumplir necesariamente los avisos de seguridad del capítulo 2.

En caso de duda, ¡recurra necesariamente a la ayuda técnica de su distribuidor!

5. Inspección, mantenimiento y cuidado

5.1. Avisos generales



¡¡ATENCIÓN !! Peligro de sacudidas eléctricas

Cumplir necesariamente los avisos de seguridad del capítulo 2.

Controlar periódicamente el estado del cable de alimentación. Al dañarse los cables o enchufes, apagar inmediatamente el aparato y encargarlo reparar a un electricista especializado.

Controlar necesariamente la existencia y legibilidad de los avisos de peligro, cambiar en caso necesario (ver capítulo 8)

5.2. Mantenimiento

El aparato en sí no precisa mantenimiento.

5.3. Limpieza del cuerpo y de la pantalla exterior

1. ¡Apagar el aparato y sacar el enchufe!
2. Limpiar el cuerpo y la pantalla exterior con un paño suave, húmedo (bien escurrido) y un detergente fino (no usar limpiadores que contengan disolventes, ácidos o medios abrasivos)

6. Servicio

6.1. Avisos generales



¡¡ATENCIÓN !! Peligro de sacudidas eléctricas

Cumplir necesariamente los avisos de seguridad del capítulo 2.

En caso de defecto, saque inmediatamente el enchufe de la toma de red y encargue su reparación solamente a un técnico electricista. Para los avisos de servicio, véase el manual original.

En caso de duda, ¡recurra necesariamente a la ayuda técnica de su distribuidor!

6.2. Cambio de las lámparas defectuosas

1. ¡Apagar el aparato y sacar el enchufe de red!
2. ¡Cuidado, las lámparas pueden quemar!
3. Cambiar las lámparas solamente por piezas prescritas. Para los avisos de servicio, véase el manual original.

7. Puesta fuera de servicio

7.1. Avisos generales



¡¡ATENCIÓN !! Peligro de sacudidas eléctricas

Cumplir necesariamente los avisos de seguridad del capítulo 2.

7.2. Desmontaje

Sacar el enchufe de red. Desmontar en sentido inverso todos los accesorios descritos en el capítulo 4.2. Durante el desmontaje sujetar la pieza superior con ayuda de dos personas.

7.3. Transporte

Cambiar de lugar y efectuar la reconexión tal como descrito en el capítulo 4.

7.4. Gestión residual

Encargar la gestión residual a una empresa autorizada.

8. Avisos de peligro

Los avisos de peligro, ya sea en texto o en imágenes, como pegatinas, sobreimpresión y/ o en forma de estas instrucciones de servicio quedan supeditados al desgaste natural. El usuario tiene la responsabilidad de que se disponga de ellas y de que sean legibles.

Los avisos de peligro deteriorados o ausentes en el aparato han de reemplazarse inmediatamente. En caso necesario contacte con su distribuidor.

¡Guardar las instrucciones de servicio en un lugar seguro para su uso posterior!

SOMMAIRE

1. **Avant-propos**
Déclaration de conformité CE
2. **Instructions de sécurité**
 - 2.1. Définition des termes employés
 - 2.2. Explications d'ordre général
 - 2.3. Instructions de sécurité de base
3. **Vérification de l'appareil**
 - 3.1. Contrôle après livraison
4. **Transport, installation et mise en service**
 - 4.1. Choix du site d'installation et transport
 - 4.2. Installation et montage
 - 4.2.1. Appareil de comptoir vidéo
 - 4.2.2. Instructions de montage des appareils vidéo pour utilisation debout et assise
 - 4.2.2.1. Appareils vidéo pour utilisation debout, forme de livraison
 - 4.2.2.2. Appareils vidéo pour utilisation assise, forme de livraison
 - 4.3. Mise en service
 - 4.4. Réglages
5. **Révision, maintenance et entretien**
 - 5.1. Généralités
 - 5.2. Maintenance
 - 5.3. Nettoyage du boîtier et de l'écran extérieur
6. **Service**
 - 6.1. Généralités
 - 6.2. Remplacement des éléments d'éclairage défectueux
7. **Mise hors service**
 - 7.1. Généralités
 - 7.2. Démontage
 - 7.3. Changement de site
 - 7.4. Mise au rebut
8. **Panneaux de signalisation des dangers**

1. Avant-propos

Ces instructions de service ont cours de validité pour les automates de jeux vidéo utilisés sur comptoirs, debout et assis. Les numéros des pièces de rechange, les instructions de service et les réglages figurent dans le manuel original four/ni séparément avec l'appareil. En cas de doute, particulièrement si le manuel d'utilisation vous pose des difficultés de compréhension au niveau de la langue ou autres, il est impératif de faire appel à l'assistance spécialisée de votre fournisseur !

Sous réserve de modifications dans les nouvelles versions de ce manuel.

Déclaration de conformité CE

Cet appareil est conforme aux directives et aux standards de sécurité européens. Il n'est pas sujet aux directives sur les machines.

2. Instructions de sécurité

2.1. Définition des termes employés



ATTENTION !! Le non respect des instructions de sécurité peut être à l'origine de risques corporels et provoquer des blessures mortelles.

2.2. Explications d'ordre général

Les opérations effectuées sur l'appareils sont exclusivement du ressort d'un personnel spécialisé pour éviter tout risque de blessures, qui risqueraient également d'être à l'origine de séquelles durables. Il en résulterait des réparations onéreuses, le remplacement de composants du système, l'extinction des droits de garantie.

L'installation et les travaux de réparation doivent être exclusivement effectués par un personnel spécialisé, les travaux de service uniquement par un personnel formé à cet effet. Le propriétaire de cet appareil doit s'assurer que toutes les personnes chargées de l'installation, de la mise en service, de la maintenance, des réparations et de l'entretien sont qualifiées pour ce faire. Il est impératif qu'elles aient pris connaissance et compris les instructions de sécurité et les chapitres correspondants de ce manuel.

Conserver les instructions de service dans un endroit sûr pour pouvoir les consulter en cas de besoin !

Toute responsabilité est exclue pour les accidents, les blessures et des détériorations résultant d'une manutention non appropriée, d'une utilisation non conforme et de transformations réalisées sur l'initiative de l'utilisateur ! Il est expressément interdit, pour des raisons de sécurité, d'effectuer toute transformation ou modification sur l'automate.

Veuillez contacter votre fournisseur pour toute demande de renseignements complémentaires ou en cas de doute.

Les instructions de service doivent être respectées à la lettre ! Il s'agit de votre sécurité.

2.3. Instructions de sécurité de base

L'appareil ne doit être utilisé que si l'installation a été réalisée conformément aux instructions stipulées dans ce manuel.

La tension et la fréquence de service de l'appareil doivent correspondre à la tension et à la fréquence du réseau. Les caractéristiques électriques figurent sur la plaque signalétique située à l'arrière de l'appareil. Raccorder exclusivement l'appareil à une prise de courant installée correctement, équipée d'un fusible et d'une prise de terre.

Monter et utiliser l'appareil exclusivement dans des locaux secs et fermés ! L'appareil est prévu pour être utilisé uniquement à des fins professionnelles.

Remplacer immédiatement les panneaux de signalisation des dangers endommagés ou manquants.



ATTENTION !! Risque d'implosion des tubes cathodiques et des tubes au néon

Installer l'appareil sur un support stable et solide et l'y fixer si nécessaire. Un appareil qui tombe peut provoquer l'implosion des tubes cathodiques et des tubes au néon. Les éclats de verre projetés peuvent occasionner des blessures graves.



ATTENTION !! Risques d'électrocution

Avant d'ouvrir l'appareil, retirer TOUJOURS la fiche de la prise de courant ! Ne jamais toucher la prise avec des mains mouillées. L'arrière de l'appareil doit être ouvert exclusivement par un personnel spécialisé. Les hautes tensions accessibles régnant à l'intérieur de l'appareil et mortelles sont encore présentes lorsque la prise secteur a été retirée.



ATTENTION !! Risques d'incendie

Utiliser exclusivement les fusibles prescrits. Ne jamais obstruer les fentes d'aération des automates de jeux. La température de l'environnement de doit pas excéder 40°C. Ne pas surcharger le secteur et les lignes d'alimentation.

Dans le cas d'un dérangement, retirer immédiatement la fiche de la prise de courant et faire effectuer la réparation par un personnel spécialisé uniquement. Tirer sur la fiche, pas sur le câble.

Dans le cas d'une recherche d'erreur, ne jamais retirer les connexions enfichables située à l'intérieur de l'appareil si ce dernier est sous tension. Couper la tension avant d'effectuer toute réparation !

Utiliser exclusivement des pièces de rechange d'origine .

Le non respect des points énumérés ci-dessus peut vous mettre en danger de mort!

3. Vérification de l'appareil

3.1. Contrôle après livraison

Vérifier dès la livraison si l'appareil n'a subi aucun dommage pendant le transport. Noter les détériorations visibles sur les papiers de livraison de l'entreprise qui a effectué le transport, ou les communiquer immédiatement après la réception pour assurer votre recours.

Ouvrir l'appareil et s'assurer que tous les modules et raccords sont bien fixés.

Retirer le matériel de montage qui se trouve à l'intérieur de l'appareil ou dans le boîtier caisse.

Si la prise secteur n'est pas conforme à la norme prévue sur le site d'installation, raccorder la prise convenable au câble d'alimentation.



ATTENTION !! Risques d'électrocution

Le raccordement de la prise secteur doit être effectué exclusivement par un personnel spécialisé. Vous vous mettez en danger, ainsi que d'autres personnes si vous ne respectez pas ce point !

Sortir l'élément de tête de l'emballage, ou le siège fourni éventuellement séparément. Ne montez ces éléments que lorsque l'appareil se trouve sur le site d'installation, vous risquez sinon de les endommager pendant le transport.

4. Transport, installation et mise en service

4.1. Choix du site d'installation et transport

Effectuer le montage et la mise en service dans des locaux secs uniquement ! Il est strictement interdit de monter l'appareil à l'air libre ou dans des locaux humides. L'humidité peut provoquer des accidents par décharges électriques ou occasionner des erreurs dans l'appareil. Eviter d'exposer l'appareil aux rayons directs du soleil.

Avant d'effectuer le transport, vérifier les voies et les possibilités de transport sur le site d'installation. Prêter une attention particulière sur les sols inclinés si l'appareil est muni de roulettes.

Ne déplacer l'appareil que si le nombre de personnes nécessaires pour ce faire est suffisant. Prendre garde aux éléments d'éclairage bas.

Installer l'appareil sur un sol plane et solide. Ne pas obstruer les ouvertures de ventilation à l'arrière de l'appareil. Respecter un écart suffisant par rapport au mur (10 cm minimum).

Ne pas placer l'appareil à proximité

- a) d'installations de première urgence, comme par ex.
 - sorties de secours
 - extincteurs, etc.
- b) de conteneurs renfermant des produits facilement inflammables, de l'eau ou des produits chimiques
- c) de sources de chaleur, comme par ex.
 - radiateurs
 - ouvertures de climatiseurs
 - vitrines exposées aux rayons directs du soleil, etc.

Ne pas exposer l'appareil à des contraintes pouvant perturber ses fonctions ou provoquer un dérangement, comme par ex.

- importantes vibrations
- présence extrême de poussière ou de saletés
- rayonnements directs du soleil ou chaleur
- pluie ou humidité
- magnétisme ou ondes radio importantes

Une prise secteur dotée d'une prise de terre et d'un fusible doit être installée correctement sur le site d'installation.

Ne pas surcharger le circuit de courant auquel l'appareil est raccordé.

Poser le câble secteur de manière à ce que personne ne puisse y trébucher. Le non respect de ce point peut mener à des blessures graves et à une détérioration du câble secteur.

Ne jamais plier le câble secteur ou y poser d'objets lourds. L'isolation pourrait en être endommagée, découvrant ainsi le câble, et provoquer des risques d'électrocution, un court-circuit ou un risque d'incendie.

4.2. Installation et montage

Placer l'appareil. Ne pas encore brancher la prise secteur, mais attendre que l'installation soit terminée !



ATTENTION !! Risque d'implosion des tubes cathodiques et des tubes au néon
Respecter impérativement les instructions de sécurité stipulées au chapitre 2.3.

4.2.1. Les appareils de compteur vidéo sont livrés entièrement montés. Il n'est pas nécessaire d'effectuer de montages supplémentaires. Installer l'appareil dans un endroit sûr !

4.2.2. Instructions de montage des appareils vidéo pour utilisation debout et assise

Si des accessoires sont fournis avec l'appareil, les fixer sûrement au moyen des vis fournies dans le sachet accompagnant l'appareil. L'élément de tête doit être maintenu par 2 assistants au moins. Utiliser une échelle ou un escabeau si nécessaire. Brancher les connexions des accessoires si ces derniers sont également fournis.

Réaliser correctement les connexions à la terre.

Se reporter au manuel pour y consulter les instructions de montage.

En cas de doute, contactez impérativement votre fournisseur !

4.2.2.1. Appareils vidéo pour utilisation debout, forme de livraison

- a) monté complètement et / ou
- b) avec élément de tête livré séparément (éclairé ou non) et / ou
- c) avec unité de commande livrée séparément

4.2.2.2. Appareils vidéo pour utilisation assise, forme de livraison

- a-c) comme pour les appareils vidéo utilisés debout et / ou
- d) avec siège livré séparément

4.3. Mise en service

Positionner l'appareil de niveau au moyen des pieds de réglage à visser, si l'appareil en est équipé. Il faut que l'appareil soit absolument stable. Les pieds doivent être revêtus de pièces en caoutchouc si le sol est glissant.

Vérifier si tous les modules et toutes les connexions sont bien fixés. Faire vérifier par un spécialiste la fixation correcte de toutes les connexions de protection de toutes les parties métalliques dénudées.

Désactiver l'interrupteur principal. Ne brancher la prise secteur que lorsque tous les points énumérés ci-dessus ont été respectés.

Activer l'interrupteur principal. Dans le cas de bruits anormaux, d'apparition de fumée ou d'odeurs inhabituelles lorsque l'appareil est mis en service, débrancher immédiatement la prise secteur et demander conseil à un spécialiste ! Contactez impérativement votre fournisseur en cas de doute.



ATTENTION !! Risques d'incendie

Ne jamais continuer à utiliser un appareil défectueux.

4.4. Réglages

Effectuer les réglages propres au programme et au modèle d'appareil conformément aux instructions spécifiées dans le manuel original fourni.



ATTENTION !! Risques d'électrocution

Respecter impérativement les instructions de sécurité stipulées au chapitre 2.

En cas de doute, contactez impérativement l'assistance spécialisée de votre revendeur !

5. Révision, maintenance et entretien

5.1. Généralités



ATTENTION !! Risques d'électrocution

Respecter impérativement les instructions de sécurité stipulées au chapitre 2.

Vérifier régulièrement l'état du câble secteur. Mettre l'appareil hors service immédiatement si le câble secteur ou la prise secteur sont endommagés et les faire réparer aussitôt par un électricien.

Vérifier impérativement si les panneaux de signalisation des dangers sont en place et lisibles et les remplacer si nécessaire (voir le chapitre 8).

5.2. Maintenance

L'appareil est exempt de maintenance.

5.3. Nettoyage du boîtier et de l'écran extérieur

1. Mettre l'appareil hors service et débrancher la prise secteur.
2. Nettoyer le boîtier et l'écran extérieur au moyen d'un chiffon doux et humide (pas mouillé) et d'un produit de nettoyage doux (ne pas employer de solvants ou des produits de nettoyage contenant des acides ou des produits de nettoyage à récurer).

6. Service

6.1. Généralités



ATTENTION !! Risques d'électrocution

Respecter impérativement les instructions de sécurité stipulées au chapitre 2.

En cas de panne, débrancher immédiatement la prise secteur et faire réparer l'appareil par un spécialiste uniquement. Respecter les instructions de sécurité stipulées dans le manuel original.

En cas de doute, contactez impérativement l'assistance spécialisée de votre fournisseur!

6.2. Remplacement des éléments d'éclairage défectueux

1. Mettre l'appareil hors service.
2. Attention! Les éléments d'éclairage peuvent être chauds !
3. Remplacer les éléments d'éclairage par des pièces autorisées. Respecter les instructions de sécurité stipulées dans le manuel original.

7. Mise hors service

7.1. Généralités



ATTENTION !! Risques d'électrocution

Respecter impérativement les instructions de sécurité stipulées au chapitre 2.

7.2. Démontage

Débrancher la prise secteur. Démontez tous les accessoires décrits au chapitre 4.2 dans l'ordre inverse. Se faire aider par au moins 2 assistants pour démonter l'élément de tête.

7.3. Changement de site

Effectuer le transport et la remise en service conformément aux instructions décrites au chapitre 4.

7.4. Mise au rebut

La mise au rebut doit être effectuée par une entreprise spécialisée.

8. Panneaux de signalisation des dangers

Les panneaux de signalisation des dangers, qu'ils se présentent sous forme de texte ou de figures, qu'ils soient imprimés sur l'appareil et / ou sous forme de ces instructions de service, sont soumis à une usure naturelle. L'exploitant assume la responsabilité pour le fait qu'ils soient toujours présents et lisibles.

Les panneaux de signalisation des dangers détériorés ou manquants doivent être remplacés immédiatement. Contactez votre fournisseur en cas de besoin.

Conserver les instructions de service dans un endroit sûr pour pouvoir les consulter en cas de besoin.

SISÄLLYSLUETTELO

1. **Esipuhe**
EC-yhdenmukaisuusvakuutus
2. **Turvaohjeita**
 - 2.1. Käsitteen määrittely
 - 2.2. Yleisiä selostuksia
 - 2.3. Perustavanlaatuisia turvaohjeita
3. **Laitteen tarkastus**
 - 3.1. Tarkastus laitteen saavuttua
4. **Kuljetus, pystytys ja käyttöönotto**
 - 4.1. Pystytyspaikan valinta ja kuljetus
 - 4.2. Pystytys ja asentaminen
 - 4.2.1. Pöytämallin videopeliautomaatti
 - 4.2.2. Seisoma- ja istumamallin videopeliautomaattien asennusohjeita
 - 4.2.2.1. Seisomamallin videopeliautomaatti, toimitusmuoto
 - 4.2.2.2. Istumamallin videopeliautomaatti, toimitusmuoto
 - 4.3. Käyttöönotto
 - 4.4. Säätyöt
5. **Säännöllinen tarkastus, huolto ja hoito**
 - 5.1. Yleisiä ohjeita
 - 5.2. Huolto
 - 5.3. Kotelon ja kuvaruudun ulkopinnan puhdistaminen
6. **Huolto**
 - 6.1. Yleisiä ohjeita
 - 6.2. Viallisten valaisinyksiköiden vaihtaminen
7. **Käytöstäotto**
 - 7.1. Yleisiä ohjeita
 - 7.2. Purkaminen
 - 7.3. Siirtäminen
 - 7.4. Hävittäminen
8. **Varoitukset**

1. Esipuhe

Nämä käyttöohjeet on tarkoitettu pöytä-, seisoma- ja istumamallin videopeliautomaateille. Varaosien numerot, huolto-ohjeet ja säätötyöt, ks. erillistä laitteen mukana toimitettua alkuperäistä käsikirjaa. Epäselvissä tapauksissa, erityisesti myös alkuperäisen käsikirjan yhteydessä esiintyvissä kielellisissä tai muunlaisissa ymmärtämisvaikeuksissa, on ehdottomasti käytettävä myyntiliikkeen asiantuntevaa apua!

Oikeus tämän käsikirjan muutoksiin uusien painosten muodossa pidätetään.

EC-yhdenmukaisuusvakuutus

Tämä laite on Euroopan turvallisuusdirektiivien ja standardien mukainen. Laite ei kuulu konedirektiivin alaisuuteen.

2. Turvaohjeita

2.1. Käsitteen määrittely



VAROITUS !! Turvaohjeiden laiminlyönnistä voi olla seurauksena henkilövahingot tai hengenmenetys.

2.2. Yleisiä selostuksia

Laitteeseen saavat puuttua vain sähköalan ammattilaiset, muussa tapauksessa vaarana on loukkaantuminen sekä pysyvät laitevauriot. Tästä olisi taas seurauksena kalliit korjaustyöt, järjestelmäkomponenttien vaihto ja takuuoikeuksien raukeaminen.

Asennus- ja korjaustöitä saavat suorittaa vain sähköalan ammattilaiset, huoltotöitä vain laitteeseen perehtynyt henkilöstö. Laitteen omistajan täytyy varmistua siitä, että kaikki henkilöt, jotka ovat tekemisissä tämän laitteen pystytyksen, käyttöönoton, huolto-, korjaus- ja kunnostustöiden kanssa, ovat päteviä tehtävään ja että he ovat ennen töiden aloittamista ehdottomasti lukeneet ja ymmärtäneet tarpeelliset turvaohjeet ja niihin liittyvät käsikirjan luvut.

Käyttöohjeita on ehdottomasti säilytettävä luotettavassa paikassa myöhempää käyttöä varten!

Tapaturmista, loukkaantumisista tai vaurioista ei vastata, jos laitetta käsitellään epäasianmukaisesti tai sitä käytetään määräysten vastaisesti tai sen rakennetta muutetaan omavaltaisesti! Automaatin omavaltaiset rakenteelliset tai muut muutokset ovat turvallisuusyistä nimenomaisesti kiellettyjä.

Lisäkysymyksissä tai epäselvässä tapauksessa tulee ottaa yhteyttä myyntiliikkeeseen.

Turvaohjeita on noudatettava tarkasti! Kysymys on omasta turvallisuudestasi.

2.3. Perustavanlaatuisia turvaohjeita

Laitetta saa käyttää vain, kun se on pystytetty määräysten ja käsikirjan mukaisesti.

Laitteen käyttöjännitteen ja -taajuuden täytyy vastata verkkovirran jännitettä ja taajuutta. Sähkötiedot, ks. laitteen takaosassa olevaa tyyppikilpeä. Laitteen saa liittää vain asianmukaisesti asennettuun, suojattuun ja maadoitettuun seinäpistorasiaan.

Laitteen saa pystyttää ja ottaa käyttöön vain suljetussa, kuivassa tilassa! Laitetta saa käyttää vain ammattitarkoitukseen!

Laitteen vioittuneet tai puuttuvat varoitukset on vaihdettava heti uusiin.



VAROITUS !! Kuvaputken ja neonputkien räjähdysvaara

Laitteen saa pystyttää vain tukevalle, kantavalle alustalle, ja se on tarvittaessa kiinnitettävä. Jos laite kaatuu, kuva- tai neonputket voivat räjähtää. Ympäriinsä lentävät lasinsirut voivat aiheuttaa tällöin mitä vakavampia vammoja.



VAROITUS !! Sähköiskun vaara

Verkkopistoke on vedettävä AINA irti pistorasiasta, ennen kuin laite avataan! Verkkopistoketta ei saa koskaan koskettaa märillä käsillä. Laitteen takaseinän saavat avata vain sähköalan ammattilaiset. Laitteen sisäosassa on hengenvaarallista, kosketussuojaamatonta suurjännitettä myös verkkopistokkeen irrottamisen jälkeen. Jos tätä määräystä ei noudateta, seurauksena voi olla hengenmenetys tai vakavat vammat.



VAROITUS !! Tulipalon vaara

Sulakkeet saa vaihtaa vain määräysten mukaisiin sulakkeisiin. Peliautomaatin tuuletusrakoja ei saa koskaan peittää. Ympäristön lämpötila ei saa kohota yli 40°C. Verkkovirtapiiriä ja syöttöjohtoja ei saa ylikuormittaa.

Jos laitteessa on vikaa, verkkopistoke on vedettävä heti irti pistorasiasta ja korjaustyöt annettava vain sähköalan ammattilaisten tehtäväksi. Pistokkeen saa irrottaa vain pistokkeesta, ei sähköjohdosta vetämällä.

Laitteen sisässä olevia pistoliittimiä ei saa koskaan vetää vianhaun yhteydessä irti tai pistää paikalleen, kun laitteessa on jännitettä. Korjaustöitä saa suorittaa aina vain, kun laitteessa ei ole jännitettä!

Käyttää saa vain alkuperäisiä varaosia.

Edellä mainittujen määräysten laiminlyöminen voi olla hengenvaarallista!

3. Laitteen tarkastus

3.1. Tarkastus laitteen saavuttua

Laite tulee tarkastaa toimituksen saavuttua, näkykö siinä kuljetusvaurioita. Näkyvät vauriot tulee merkitä laitteen toimittaneen huolitsijan huolintapapereihin tai ilmoitettava välittömästi tavarantoimittajalle, jotta oikeudet säilyvät.

Laite avataan ja kaikkien rakenneryhmien ja pistoliittimien kiinnitys tarkastetaan.

Mukaan pakattu asennusmateriaali otetaan pois laitteen sisältä tai kassalaatikosta.

Jos mukana toimitettu verkkopistoke ei ole maassa voimassa olevien määräysten mukainen, verkkokaapeliin on liitettävä sopiva verkkopistoke.



VAROITUS !! Sähköiskun vaara

Verkkopistokkeen saavat liittää vain sähköalan ammattilaiset. Laiminlyönnillä vaarannat itsesi ja muut!

Erillinen yläosa tai istuinyksikkö, jos laitteeseen kuuluu tällaiset, otetaan ulos pakkauksesta. Nämä osat asennetaan vasta pystytyspaikalla, koska ne voivat vioittua kuljetuksessa.

4. Kuljetus, pystytys ja käyttöönotto

4.1. Pystytyspaikan valinta ja kuljetus

Laitteen saa pystyttää ja ottaa käyttöön vain suljetussa, kuivassa tilassa! Pystytys ulos tai kosteaan tai märkään tilaan on ankarasti kielletty. Sisään tunkeutuvasta kosteudesta voi

olla seurauksena sähköiskutapaturmat tai laitteen sisäosien vioittuminen. Suoraa auringonsäteilyä on vältettävä.

Kuljetusreitit ja -mahdollisuudet pystytyspaikalla tulee tarkastaa ennen kuljetusta. Jos laitetta kuljetetaan kuljetuspyörillä, on oltava erityisen varovainen kaltevilla alustoilla.

Laitteen siirtämiseen tulee käyttää riittävä määrä henkilöitä. Varo alhaalla riippuvia valaisimia.

Laite pystytetään tasaiselle, kantavalle alustalle. Laitteen takaosan tuuletusaukkoja ei saa peittää. Seiniin on pidettävä riittävä etäisyys (vähint. 10 cm).

Laitetta ei saa sijoittaa seuraavien kohteiden läheisyyteen:

- a) pelastusjärjestelmät, kuten esim.
 - varauloskäytävät,
 - palonsammuttimet jne.
- b) säiliöt, jotka sisältävät syttyviä aineita, vettä tai kemikaaleja,
- c) lämpölähteet, kuten esim.
 - lämmityspatterit,
 - ilmastointilaitteiden aukot,
 - näyteikkunat, joihin aurinko paistaa suoraan jne.

Laitetta ei saa kuormittaa millään tavalla, mikä aiheuttaa toimintahäiriöitä tai vikoja, kuten esim.

- voimakas värinä,
- äärimmäinen pöly tai lika,
- suora auringonsäteily tai kuumuus,
- sade tai kosteus,
- voimakas magneettisuus tai radioaallot.

Laitteen pystytyspaikan vieressä täytyy olla asianmukaisesti asennettu, maadoitettu ja sulakkeilla suojattu seinäpistorasia.

Virtapiiriä, johon laite liitetään, ei saa ylikuormittaa.

Verkkokaapeli on asennettava siten, että kukaan ei voi kompastua siihen. Laiminlyönnistä voi olla seurauksena vakavat vammat tai verkkokaapelin vioittuminen.

Verkkokaapelia ei saa taivuttaa jyrkälle mutkalle tai asettaa sen päälle raskaita esineitä, koska eristys voi tästä vioittua, jolloin verkkojännitteen koskettaminen on mahdollista tai seurauksena voi olla oikosulku ja tästä aiheutuva tulipalo.

4.2. Laitteen pystytys ja asentaminen

Laite sijoitetaan paikalleen, verkkopistoroketta ei liitetä vielä pistorasiaan, vaan vasta kun pystytys on päättynyt!



VAROITUS !! Kuvaputken ja neonputkien räjähdysvaara

Luvun 2.3 turvaohjeet on ehdottomasti otettava huomioon.

4.2.1. Pöytämallin videopeliautomaatit toimitetaan kokonaan kokoonpantuna. Lisäasennustyöt eivät ole tarpeen. On huolehdittava vain tukevasta pystytyspaikasta!

4.2.2. Seisoma- ja istumamallin videopeliautomaatit

Erilliset tarviketosat, jos tällaisia kuuluu laitteeseen, kiinnitetään laitteeseen luotettavalla tavalla laitteen mukaan pakatuilla ruuveilla. Vähintään 2 avustajan tulee pitää yläosasta kiinni asennuksen aikana, jolloin on käytettävä nousuapuvälineitä, esim. tikapuita tai askelmia. Tarviketosien pistoliittimet, jos tällaisia kuuluu laitteeseen, pistetään paikalleen.

Suojajohtimet liitetään luotettavalla tavalla.

Asennusohjeet, ks. alkuperäistä käsikirjaa.

Epäselvässä tapauksessa on ehdottomasti käytettävä myyntiliikkeen asiantuntevaa apua!

4.2.2.1. Seisomallin videopeliautomaatti, mahdolliset toimitusmuodot:

- a) kokonaan kokoonpantu ja/tai
- b) erikseen pakattu yläosa (valaistu tai valaisematon) ja/tai
- c) erikseen pakattu ohjausyksikkö.

4.2.2.2. Istumamallin videopeliautomaatti, mahdolliset toimitusmuodot:

- a-c) kuten seisomamallin videopeliautomaatti ja/tai lisäksi
- d) erikseen pakattu istuinyksikkö.

4.3. Käyttöönotto

Laite asetetaan tarkasti vaakasuoraan korkeussäädettävillä jalkaruuveilla, jos laitteessa on tällaiset. Laitteen täytyy seisoa ehdottoman tukevasti alustallaan. Sileillä lattioilla laitteen jalkojen alle asetetaan kumitulpat.

Kaikki rakenneryhmät ja pistoliittimet tarkastetaan, ovatko ne lujasti kiinni. Erityisesti kaikkien kosketussuojaamattomien metalliosien suojajohdinten liitäntöjen kiinnitys täytyy antaa sähköalan ammattilaisen tarkastettavaksi!

Pääkytkin kytketään pois päältä. Verkkopistoke pistetään pistorasiaan vasta, kun kaikki edellä mainitut seikat ovat varmasti kunnossa.

Pääkytkin kytketään päälle. Jos kuuluu epätavallisia ääniä, laitteesta tulee savua tai epätavallista hajua päällekytkennän jälkeen, verkkopistoke on vedettävä heti irti pistorasiasta ja paikalle on kutsuttava sähköalan ammattilainen. Epäselvässä tapauksessa on ehdottomasti otettava yhteyttä myyntiliikkeeseen.



VAROITUS !! Tulipalon vaara

Missään tapauksessa viallisen laitteen käyttämistä ei saa jatkaa korjaamattomana.

4.4. Säätyöt

Ohjelma- ja mallikohtaiset säätyöt on selostettu mukana seuraavassa alkuperäisessä käsikirjassa.



VAROITUS !! Sähköiskun vaara

Luvun 2 turvaohjeet on ehdottomasti otettava huomioon.

Epäselvässä tapauksessa on ehdottomasti käytettävä myyntiliikkeen asiantuntevaa apua!

5. Säännöllinen tarkastus, huolto ja hoito

5.1 Yleisiä ohjeita



VAROITUS !! Sähköiskun vaara

Luvun 2 turvaohjeet on ehdottomasti otettava huomioon.

Verkkokaapelin kunto on tarkastettava säännöllisesti. Jos kaapeli tai pistoke on viallinen, laite on otettava heti pois käytöstä ja korjautettava sähköalan ammattilaisella.

On ehdottomasti tarkastettava, ovatko varoitukset paikoillaan ja luettavassa kunnossa, tarvittaessa ne on vaihdettava (ks. luku 8).

5.2. Huolto

Laite itse ei tarvitse huoltoa.

5.3. Kotelon ja kuvaruudun ulkopinnan puhdistaminen

1. Laite on kytkettävä pois päältä ja verkkopistoke vedettävä irti!
2. Kotelo ja kuvaruudun ulkopinta puhdistetaan pehmeällä, kostealla (ei märällä) rievulla käyttäen mietoa puhdistusainetta (käyttää ei saa liuottimia, happoa tai hankaavia aineita sisältäviä puhdistusaineita).

6. Huolto

6.1. Yleisiä ohjeita



VAROITUS !! Sähköiskun vaara

Luvun 2 turvaohjeet on ehdottomasti otettava huomioon.

Jos laitteessa on vikaa, verkkopistoke on vedettävä heti irti pistorasiasta ja laite korjautettava sähköalan ammattilaisella. Huolto-ohjeet, ks. alkuperäistä käsikirjaa.

Epäselvässä tapauksessa on ehdottomasti käytettävä myyntiliikkeen asiantuntevaa apua!

6.2. Viallisten valaisimien vaihtaminen

1. Laite on kytkettävä pois päältä ja verkkopistoke vedettävä irti!
2. Varo! Valaisin voi olla kuuma!
3. Valaisimen saa vaihtaa vain määrättyjä osia käyttäen. Huolto-ohjeet, ks. alkuperäistä käsikirjaa.

7. Käytöstäotto

7.1. Yleisiä ohjeita



VAROITUS !! Sähköiskun vaara

Luvun 2 turvaohjeet on ehdottomasti otettava huomioon.

7.2. Purkaminen

Verkkopistoke vedetään irti seinäpistorasiasta. Kaikki luvussa 4.2 selostetut tarvikeosat puretaan irti päinvastaisessa järjestyksessä. Vähintään 2 avustajan on pidettävä laitteen yläosasta kiinni.

7.3. Siirtäminen

Laitteen siirtäminen ja jälleenkäyttöönnotto suoritetaan luvussa 4 selostetulla tavalla.

7.4. Hävittäminen

Laite annetaan hyväksytyyn jätehuoltoon hävitettäväksi.

8. Varoitukset

Varoitukset, olivatpa ne sitten tekstin tai kuvien, etiketin, painannan ja/tai näiden käyttöohjeiden muodossa, kuluvat luonnostaan käytössä. Käyttäjä vastaa siitä, että ne ovat paikallaan ja luettavassa kunnossa.

Vialliset tai puuttuvat varoitukset on korvattava heti uusilla. Ota tarvittaessa yhteyttä myyntiliikkeeseen.

Käyttöohjeita on ehdottomasti säilytettävä luotettavassa paikassa myöhempää käyttöä varten!

SOMMARIO

1. **Premessa**
Dichiarazione di conformità CE
2. **Indicazioni di sicurezza**
 - 2.1. Definizione dei concetti
 - 2.2. Chiarimenti generali
 - 2.3. Indicazioni di sicurezza fondamentali
3. **Verifica dell'apparecchio**
 - 3.1. Controllo dopo la fornitura
4. **Trasporto, montaggio e messa in esercizio**
 - 4.1. Scelta del luogo di montaggio e trasporto
 - 4.2. Posa e montaggio
 - 4.2.1. Apparecchio video da bacheca
 - 4.2.2. Istruzioni di montaggio per l'apparecchio video con comando in piedi e a sedere
 - 4.2.2.1. Apparecchio video con comando in piedi, stato di fornitura
 - 4.2.2.2. Apparecchio video con comando a sedere, stato di fornitura
 - 4.3. Messa in esercizio
 - 4.4. Impostazioni
5. **Ispezione, manutenzione e cura**
 - 5.1. Indicazioni generali
 - 5.2. Manutenzione
 - 5.3. Pulizia dell'involucro e dello schermo esterno
6. **Riparazione**
 - 6.1. Indicazioni generali
 - 6.2. Sostituzione di corpi luminosi difettosi
7. **Messa fuori esercizio**
 - 7.1. Indicazioni generali
 - 7.2. Smontaggio
 - 7.3. Spostamento
 - 7.4. Smaltimento
8. **Avvertenze**

1. Premessa

Queste istruzioni d'uso valgono per videogames da bacheca, con comando in piedi e a sedere. Per i numeri dei pezzi di ricambio, per le istruzioni di riparazione e per gli interventi di regolazione si veda il manuale originale fornito insieme all'apparecchio. In caso di incertezza, in particolar modo in caso di problemi di comprensione di tipo linguistico o di difficoltà di qualunque altro tipo rivolgersi necessariamente al proprio rivenditore di fiducia!

Ci si riserva il diritto di apportare modifiche dei contenuti nelle versioni future del presente manuale.

Dichiarazione di conformità CE

Il presente apparecchio soddisfa le direttive e gli standard europei di sicurezza. Esso non rientra nella categoria della direttiva macchine.

2. Indicazioni di sicurezza

2.1. Definizione dei concetti



AVVERTENZA !! La mancata osservanza delle indicazioni di sicurezza può condurre a infortuni o a lesioni mortali.

2.2. Note generali

Gli interventi all'interno dell'apparecchio devono essere eseguiti esclusivamente da un elettricista specializzato, in caso contrario persiste il pericolo di infortunio o di danno permanente all'apparecchio. Ne conseguirebbero costose riparazioni, la sostituzione di componenti di sistema cosiccome l'estinzione di qualsiasi garanzia.

Gli interventi di riparazione e di installazione devono essere eseguiti esclusivamente da un elettricista specializzato. I lavori di servizio e assistenza solamente da personale addestrato. Il proprietario del presente apparecchio deve assicurarsi che tutto il personale addetto alla posa, alla messa in esercizio, alla manutenzione cosiccome alla riparazione dell'apparecchio sia adeguatamente specializzato e che prima di procedere ad effettuare gli interventi di cui sopra abbia letto e compreso le indicazioni di sicurezza e i relativi capitoli del manuale.

Il manuale d'istruzioni va conservato in un luogo sicuro per l'uso futuro!

In caso di uso errato, impiego non corrispondente alla destinazione dell'apparecchio e in caso di intervento sull'apparecchio stesso non si risponde per incidenti, lesioni o danni derivanti. Interventi o modifiche di propria iniziativa sull'apparecchio sono espressamente vietate per motivi di sicurezza.

In caso di ulteriori quesiti o per maggiori informazioni rivolgetevi al vostro rivenditore.

È assolutamente necessario rispettare le indicazioni di sicurezza! Ne va della vostra sicurezza.

2.3. Indicazioni di sicurezza fondamentali

L'apparecchio può essere fatto funzionare solamente se la messa in posa è avvenuta esattamente in conformità a quanto contenuto nel manuale.

La tensione e la frequenza di esercizio dell'apparecchio devono corrispondere alla tensione e alla frequenza della rete elettrica. Per i dati elettrici si veda la targhetta di omologazione situata sul retro dell'apparecchio. Collegare l'apparecchio esclusivamente ad una presa elettrica regolarmente installata, protetta e collegata a terra.

La messa in posa e la messa in esercizio vanno effettuate esclusivamente all'interno di locali chiusi ed asciutti! L'apparecchio deve essere utilizzato esclusivamente a fini commerciali.

Gli adesivi di avvertenza danneggiati o mancanti devono essere immediatamente rimpiazzati con adesivi nuovi.



AVVERTENZA !! Pericolo di implosione del tubo catodico e del neon.

L'apparecchio va messo in posa solamente su pavimentazioni stabili e sufficientemente portanti, se necessario fissandovelo. La caduta dell'apparecchio può causare l'implosione del tubo catodico o del neon. Le schegge derivanti dall'implosione possono arrecare serie lesioni personali.



AVVERTENZA !! Pericolo di folgorazione

Prima di aprire l'apparecchio staccare SEMPRE la spina dalla presa di corrente! Non toccare mai la spina con mani bagnate. La parete posteriore dell'apparecchio può essere aperta esclusivamente da un elettricista specializzato. All'interno dell'apparecchio sono presenti alte tensioni su parti esposte e accessibili, anche dopo aver staccato la spina dell'apparecchio e che possono provocare la morte o serie lesioni personali.



AVVERTENZA !! Pericolo di incendio

Sostituire i fusibili danneggiati solamente con i fusibili prescritti. Mai ostruire le fessure di aerazione del videogame. Non esporre l'apparecchio a temperature ambientali superiori ai 40 °C, Non sovraccaricare i cavi di alimentazione o il circuito elettrico.

In caso di difetto estrarre subito la spina elettrica dalla presa della corrente e far eseguire l'intervento di riparazione esclusivamente da un elettricista specializzato. Tirare solo facendo forza sulla spina elettrica e non sul cavo.

Durante la ricerca di un malfunzionamento non estrarre o infilare mai dei connettori all'interno dell'apparecchio con l'apparecchio ancora sotto tensione. Tutti gli interventi vanno sempre eseguiti senza tensione!

Utilizzare esclusivamente ricambi originali.

La mancata osservazione delle indicazioni sopra riportate significa pericolo di morte!

3. Verifica dell'apparecchio

3.1. Controllo dopo la fornitura

Verificare subito dopo la fornitura che l'apparecchio sia in ordine e che non presenti danni. Annotare i danni visibili sulle bolle di spedizione del trasportatore o farne comunicazione subito dopo il ricevimento dell'apparecchio, in modo da assicurarsi il diritto di rivendicazione.

Aprire l'apparecchio e verificare la correttezza dei vari collegamenti dei gruppi costruttivi e dei connettori.

Estrarre il materiale di montaggio fornito insieme all'apparecchio dall'interno dell'apparecchio stesso o dalla cassetta della cassa.

Se la spina elettrica non corrisponde alla norma utilizzata localmente utilizzare una spina adatta collegandola al cavo di alimentazione.



AVVERTENZA !! Pericolo di folgorazione

Il collegamento della spina elettrica deve essere effettuato esclusivamente da un elettricista specializzato. In caso di mancata osservazione di tale regola mettete a rischio la vostra vita e la vita degli altri.

Se presente, estrarre dalla confezione la testata o il sedile. Il loro montaggio va effettuato solamente sul luogo di posa, altrimenti essi si potrebbero danneggiare durante il trasporto.

4. Trasporto, montaggio e messa in esercizio

4.1. Scelta del luogo di montaggio e trasporto

La posa e la messa in esercizio vanno effettuate esclusivamente all'interno di locali chiusi ed asciutti. La posa e l'erezione dell'apparecchio all'aperto o in locali bagnati o umidi non è assolutamente consentita. Delle infiltrazioni di umidità possono causare lesioni personali per folgorazione o causare malfunzionamenti interni dell'apparecchio.

Verificare prima di effettuare il trasporto quali sono le vie di accesso e le possibilità di trasporto disponibili sul luogo di montaggio dell'apparecchio. In caso di apparecchi dotati di ruote di trasporto fare particolarmente attenzione ai pavimenti inclinati.

Spostare l'apparecchio solamente con l'aiuto di un numero sufficiente di persone. Fare attenzione a lampade sospese ad altezze ridotte.

Appoggiare l'apparecchio su un pavimento piano e sufficientemente portante. Non ostruire le aperture di aerazione situate sul retro dell'apparecchio e mantenere una sufficiente distanza di sicurezza dalla parete (min. 10 cm).

Non piazzare l'apparecchio nelle vicinanze di:

- a) dispositivi di soccorso, come p. es.
 - uscite di emergenza,
 - estintori etc.
- b) serbatoi con sostanze facilmente infiammabili, acqua o sostanze chimiche
- c) sorgenti di calore, come p. es.:
 - caloriferi o radiatori,
 - bocchettoni dell'impianto di condizionamento,
 - vetrine esposte direttamente ai raggi solari etc.

Non esporre l'apparecchio a carichi o a sforzi che potrebbero comprometterne il sicuro funzionamento, come per esempio:

- forti vibrazioni,
- estrema esposizione a polvere e sporco,
- irradiazione solare diretta o calore,
- pioggia od umidità,
- campi magnetici oppure onde radio di elevata intensità

Direttamente sul luogo di posa dell'apparecchio deve essere presente una presa elettrica correttamente installata, collegata a terra e protetta.

Evitare di sovraccaricare il circuito elettrico a cui è collegato l'apparecchio.

Posare il cavo di alimentazione in maniera tale che nessuno vi possa inciampare. Il mancato rispetto di tale indicazione può provocare serie lesioni personali o condurre al danneggiamento del cavo di alimentazione stesso.

Non piegare troppo il cavo di alimentazione nè appoggiarvi sopra oggetti pesanti per non danneggiare il rivestimento isolante del cavo stesso, fatto che comporterebbe il rischio di folgorazione o di cortocircuito con successivo pericolo di incendio.

4.2. Posa e montaggio dell'apparecchio

Posizionare l'apparecchio. Non inserire la spina elettrica subito, ma solamente a posa ultimata!



AVVERTENZA!! Pericolo di implosione del tubo catodico e del neon

Osservare assolutamente le indicazioni di sicurezza contenute nel capitolo 2.3.

4.2.1. Apparecchio video da bacheca

Gli apparecchi video da bacheca vengono forniti già completamente montati. Non è necessario alcun ulteriore montaggio. Assicurarvi che il luogo di montaggio dell'apparecchio sia stabile e sicuro.

4.2.2. Istruzioni di montaggio per l'apparecchio video con comando in piedi e a sedere

Se presente, fissare saldamente all'apparecchio le parti accessorie utilizzando le viti fornite insieme all'apparecchio stesso. Durante il montaggio fare sorreggere la testata da due assistenti e utilizzare una scaletta o uno sgabello. Se presenti, collegare fra di loro gli spinotti delle parti accessorie.

Assicurarsi che i collegamenti dei conduttori di protezione avvengano in maniera corretta e sicura.

Per le istruzioni di montaggio fare riferimento al manuale di istruzioni originale.

In caso di incertezza ricorrere assolutamente all'assistenza del proprio rivenditore.

4.2.2.1. Apparecchio video statico, possibili stati di fornitura

- a) completamente montato e/o
- b) con testata confezionata separatamente (illuminata o non) e/o
- c) con unità di comando confezionata separatamente

4.2.2.2. Apparecchio video a sedere, possibili stati di fornitura

- a-c) come per l'apparecchio con comando in piedi e/o aggiuntivamente
- d) con unità sedile confezionata separatamente

4.3. Messa in esercizio

Se presenti, allineare l'apparecchio con le viti inferiori regolabili in altezza. L'apparecchio deve poggiare sul pavimento in maniera assolutamente stabile. In caso di pavimenti particolarmente lisci montare sotto ai piedi dell'apparecchio dei tamponi di gomma.

Verificare che tutti i gruppi costruttivi e i connettori siano saldamente collegati. In particolare modo lasciare controllare da un elettricista che tutte le parti metalliche toccabili siano correttamente collegate al conduttore di protezione!

Posizionare su spento l'interruttore principale. Inserire la spina solamente dopo che i punti sopraccitati sono stati eseguiti a dovere.

Accendere l'interruttore principale. In caso di rumori anormali, di fumo o di odori inconsueti presenti dopo l'accensione dell'apparecchio estrarre subito la spina elettrica dalla presa di corrente e consultare un elettricista. In caso di incertezza rivolgersi assolutamente al proprio rivenditore.



AVVERTENZA !! Pericolo di incendio

Non tenere assolutamente in funzione l'apparecchio in tali condizioni.

4.4. Impostazioni

Le impostazioni dipendenti dal programma o dal modello sono deducibili dal manuale di istruzioni originale fornito insieme all'apparecchio.



AVVERTENZA !! Pericolo di folgorazione

Osservare assolutamente le indicazioni di sicurezza contenute nel capitolo 2

In caso di incertezza ricorrere assolutamente all'assistenza del proprio rivenditore.

5. Ispezione, manutenzione e cura

5.1. Indicazioni generali



AVVERTENZA !! Pericolo di folgorazione

Osservare assolutamente le indicazioni di sicurezza contenute nel capitolo 2

Verificare ad intervalli regolari lo stato del cavo di alimentazione. In caso di cavo o di spina elettrica danneggiati mettere subito fuori esercizio l'apparecchio provvedendo a chiamare un elettricista per la sua riparazione.

Verificare assolutamente che i cartellini di avvertenza siano presenti e leggibili, in caso contrario sostituirli (vedere il capitolo 8).

5.2. Manutenzione

L'apparecchio di per sè non richiede alcuna manutenzione.

5.3. Pulizia dell'involucro e dello schermo esterno

1. Spegner l'apparecchio e staccare la spina elettrica!
2. Detergere l'involucro e lo schermo esterno con un panno morbido e inumidito (non bagnato) usando un detergente dolce (non usare detersivi contenenti solventi, acidi o sostanze abrasive).

6. Riparazione

6.1. Indicazioni generali



AVVERTENZA !! Pericolo di folgorazione

Osservare assolutamente le indicazioni di sicurezza contenute nel capitolo 2

In caso di difetti dell'apparecchio estrarre subito la spina elettrica dalla presa di corrente e fare eseguire la riparazione da un elettricista. Per le istruzioni di servizio consultare il manuale di istruzioni originale.

In caso di incertezza rivolgersi assolutamente al proprio rivenditore.

6.2. Sostituzione di corpi luminosi difettosi

1. Spegner l'apparecchio e staccare la spina!
2. Attenzione, le parti luminose possono essere molto calde!
3. Sostituire le parti luminose solamente con i ricambi prescritti. Per le istruzioni di servizio consultare il manuale di istruzioni originale.

7. Messa fuori esercizio

7.1. Indicazioni generali



AVVERTENZA !! Pericolo di folgorazione

Osservare assolutamente le indicazioni di sicurezza contenute nel capitolo 2

7.2. Smontaggio

Estrarre la spina elettrica. Smontare tutte le parti accessorie in sequenza inversa a quanto riportato nel capitolo 4.2. Fare sorreggere la testata durante lo smontaggio da almeno due assistenti.

7.3. Spostamento

Eseguire lo spostamento e la rimessa in esercizio dell'apparecchio come descritto nel capitolo 4.

7.4. Smaltimento

Fare eseguire lo smaltimento da una ditta specializzata.

8. Avvertenze

Tutte le avvertenze in forma testuale o illustrativa sotto forma di adesivi, scritte e/o sotto forma di istruzioni d'uso sono soggette a naturale usura. Il gestore ha la responsabilità che tali avvertenze siano presenti e che siano sempre leggibili.

Avvertenze danneggiate o mancanti sono da sostituire immediatamente. in caso di necessità contattare il proprio rivenditore.

Conservare assolutamente le istruzioni d'uso in un luogo sicuro per l'uso futuro.

INNHOLDSFORTEGNELSE

- 1. Forord**
EF-konformitetserklæring
- 2. Sikkerhetsinformasjoner**
 - 2.1. Begrepsdefinisjon
 - 2.2. Generelle forklaringer
 - 2.3. Prinsipielle sikkerhetsinformasjoner
- 3. Kontroll av maskinen**
 - 3.1. Kontroll etter levering
- 4. Transport, oppstilling og idriftsettelse**
 - 4.1. Valg av oppstillingssted og transport
 - 4.2. Oppstilling og montasje
 - 4.2.1. Video-bordmaskin
 - 4.2.2. Montasjeinstrukser for video-gulvmaskin og video-setemaskiner
 - 4.2.2.1. Video-gulvmaskin, leveringsform
 - 4.2.2.2. Video-setemaskin, leveringsform
 - 4.3. Idriftsettelse
 - 4.4. Innstillinger
- 5. Inspeksjon, vedlikehold og pleie**
 - 5.1. Generelle informasjoner
 - 5.2. Vedlikehold
 - 5.3. Rengjøring av huset og av den ytre skjermen
- 6. Service**
 - 6.1. Generelle informasjoner
 - 6.2. Utskiftning av defekte belysningslegemer
- 7. Maskinen settes ut av drift**
 - 7.1. Generelle informasjoner
 - 7.2. Demontasje
 - 7.3. Flytting
 - 7.4. Avfallsbehandling
- 8. Advarsler**

1. Forord

Denne brukerveiledningen gjelder for bord-, gulv- eller sete-video-spilleautomater. Reservedelsnumre, serviceanvisninger og innstillinger er å finne i den separate original-håndboken. I et tvilstilfelle og spesielt ved problemer med original-håndboken av språklig eller annen type er det absolutt nødvendig å innhente sakkyndig hjelp hos forhandleren!

Rett til endringer i denne håndboken ved nye opplag forbeholdes.

EF-konformitetserklæring

Denne maskinen er i samsvar med de europeiske sikkerhetsdirektivene og standardene. Den faller ikke inn under maskin-direktivet.

2. Sikkerhetsinformasjoner

2.1. Begrepsdefinisjon



ADVARSEL !! Ignorering kan medføre personskader eller skader med døden til følge.

2.2. Generelle forklaringer

Inngrep i maskinen må kun utføres av en elektro-fagmann, ellers er det fare for personskader og alvorlige skader på maskinen. Følgen av dette vil være dyre reparasjoner, utskiftning av systemkomponenter og at garantikrav blir ugyldige.

Installasjons- og reparasjonsarbeider må kun utføres av en elektro-fagmann, servicearbeider kun av opplært personale. Eieren av denne maskinen må påse at alle personer som er involvert i oppstilling, idriftsettelse, vedlikehold, reparasjon og service av denne maskinen er tilsvarende kvalifisert og har lest og forstått de nødvendige sikkerhetsinformasjonene og de tilhørende kapitlene i håndboken før arbeidene påbegynnes.

Brukerveiledningen må under enhver omstendighet oppbevares på et sikkert sted for senere bruk!

Ved usakkyndig håndtering, ikke korrekt anvendelse og egenmektige ombygginger bærer produsenten intet ansvar for ulykker, personskader og materielle skader! Av sikkerhetsmessige årsaker er egenmektige ombygginger og forandringer på automaten strengt forbudt.

Ta kontakt med forhandleren hvis du har spørsmål eller i et tvilstilfelle.

Sikkerhetsinformasjonene må følges nøye! Det dreier seg om din sikkerhet.

2.3. Prinsipielle sikkerhetsinformasjoner

Maskinen må kun settes i drift hvis oppstillingen er utført forskriftsmessig og i samsvar med håndboken.

Maskinens driftsspenning og -frekvens må stemme overens med nettspenningen og -frekvensen. Elektriske data: se typeskiltet på maskinens bakside. Maskinen må kun koples til en forskriftsmessig installert, sikret og jordet stikkontakt.

Oppstilling og idriftsettelse må kun foretas i lukkede, tørre rom! Maskinen må kun benyttes til næringsmessige formål.

Skadede eller manglende advarsler på maskinen skal erstattes omgående.



ADVARSEL !! Implosjonsfare for billedrøret og neonrørene

Oppstilling må kun foretas på stabil, bæredyktig grunn, maskinen må eventuelt befestiges. Hvis maskinen faller, kan dette medføre implosjon av billed- eller neonrørene. Glassplinter som slynges bort kan medføre alvorlige personskader.



ADVARSEL !! Fare for elektrisk støt

Før maskinen åpnes må ALLTID nettstøpselet trekkes ut av stikkkontakten! Berør aldri nettstøpselet med våte hender. Maskinens bakvegg må kun åpnes av en elektro-fagmann. I maskinens indre er det livsfarlig høyspenning som kan berøres og som også foreligger etter at nettstøpselet er frakoplet. Ignorering kan føre til døden eller til alvorlige personskader.



ADVARSEL !! Brannfare

Sikringer må kun byttes ut mot foreskrevne sikringer. Ventilasjonsslissene i spilleautomaten må aldri blokkeres. En omgivelsestemperatur på 40°C må ikke overskrides. Nettstrømkretsen og tilførselsledningene må ikke overbelastes.

Ved en defekt skal nettstøpselet omgående trekkes ut av stikkkontakten og en reparasjon kun utføres av en elektro-fagmann. Trekk kun i støpselet, ikke i kabelen.

Ved feilsøking må aldri pluggforbindelser i maskinens indre frakoples eller tilkoples under spenning. Reparasjoner skal prinsipielt kun utføres i spenningsløs tilstand!

Det må kun benyttes original-reservedeler.

Ignorering av punktene ovenfor kan være livsfarlig!

3. Kontroll av maskinen

3.1. Kontroll etter levering

Direkte ved levering skal maskinen kontrolleres med hensyn til transportskader. Synlige skader skal noteres på spedisjonspapirene til speditøren som leverer maskinen eller meldes umiddelbart etter at produktet er mottatt, slik at kravene du har er sikret.

Åpne maskinen og kontrollér samtlige komponentgrupper og pluggforbindelser med hensyn til om de sitter korrekt.

Medpakket montasjemateriale skal fjernes fra maskinens indre eller fra kasseboksen.

Hvis nettstøpselet som er levert ikke tilsvarer de foreskrevne bestemmelser i vedkommende land, skal et passende nettstøpsel koples til nettkabelen.



ADVARSEL !! Fare for elektrisk støt

Nettstøpselet må kun tilkoples av en elektro-fagmann. Ved ignorering utsetter du deg selv og andre for fare!

Hvis en slik foreligger, skal den separate hodedelen eller seteenheden taes ut av emballasjen. Disse delene må først monteres på oppstillingsstedet, ellers er det fare for skader under transporten.

4. Transport, oppstilling og idriftsettelse

4.1. Valg av oppstillingssted og transport

Oppstilling og idriftsettelse må kun finne sted i lukkede, tørre rom! Oppstilling utendørs eller i fuktige/våte rom er strengt forbudt. Fuktighet som trenger inn i maskinen kan føre til ulykker grunnet elektrisk støt og til feil i maskinen. Unngå direkte solstråling.

Gå gjennom transportveier og -muligheter på oppstillingsstedet før transport. For maskiner med transporttrinser må man være spesielt forsiktig hvis grunnen heller.

Maskinen må kun beveges ved hjelp av et tilstrekkelig antall personer. Utvis forsiktighet ved belyningsutstyr som henger lavt.

Maskinen skal stilles opp på jevn, bæredyktig grunn. Ventilasjonsåpningene på maskinens bakside må ikke tildekkes. Hold tilstrekkelig avstand til vegg (min. 10 cm).

Ikke plassér maskinen i nærheten av:

- a) Livreddende innretninger, som f.eks.
 - nødutganger,
 - brannslukningsapparater etc.
- b) Beholdere med lett antennelige stoffer, vann eller kjemikalier,
- c) Varmekilder, som f.eks.
 - varmovner,
 - åpninger i klimaanlegg,
 - vinduer med direkte solstråling etc.

Maskinen må ikke utsettes for belastninger som kan medføre funksjonsforstyrrelser eller defekter, som f.eks.

- sterk vibrasjon,
- ekstrem støv- eller smussbelastning,
- direkte solstråling eller varme,
- regn eller fuktighet,
- sterk magnetisme eller radiobølger.

Direkte på maskinens oppstillingssted må det befinne seg en forskriftsmessig installert, jordet og sikret nettstikkontakt.

Strømkretsen som maskinen koples til må ikke overbelastes.

Nettkabelen skal legges på en slik måte at ingen kan snuble i den. Ignorering kan medføre alvorlige personskader eller skader på kabelen.

Nettkabelen må ikke legges i skarp bøy og det må ikke settes tunge gjenstander på den, ellers kan isolasjonen skades, noe som kan føre til berørbar spenning, kortslutning og dermed brann.

4.2. Oppstilling og montasje av maskinen

Plassér maskinen. Ikke stikk i nettstøpselet ennå, første etter at oppstillingen er avsluttet!



ADVARSEL !! Implosjonsfare for billedrøret og neonrørene

Det er absolutt nødvendig å overholde sikkerhetsinstruksene i kapittel 2.3.

4.2.1. Video-bordmaskiner leveres i komplett montert tilstand. Ingen ytterligere montasjearbeider er nødvendige. Sørg for et sikkert oppstillingssted!

4.2.2. Montasjeinstrukser video-gulvmaskin og video-setemaskiner

Hvis slike finnes, skal separate tilbehørsdeler festes sikkert til maskinen ved hjelp av skruene som er medlevert. Hodedelen skal sikres ved hjelp av minst 2 medhjelpere under montasjen. Oppstigningshjelp, f.eks. stige eller trapp, skal benyttes. Hvis slike finnes, skal tilbehørsdelenes pluggforbindelser plugges i.

Opprett jordlederforbindelsene på en sikker måte.

Montasjeinstrukser er å finne i original-håndboken.

I et tvilstilfelle er det absolutt nødvendig å innhente sakkyndig hjelp hos forhandleren!

4.2.2.1. Video-gulvmaskin, mulige leveringsformer:

- a) komplett montert og/eller
- b) med separat pakket hodedel (belyst eller ikke belyst) og/eller
- c) med separat pakket betjeningsenhet

4.2.2.2. Video-setemaskin, mulige leveringsformer:

- a-c) som video-gulvmaskin og/eller i tillegg
- d) med separat pakket seteenhet

4.3. Idriftsettelse

Hvis slike finnes, skal maskinen nivelleres eksakt ved hjelp av de høydejusterbare fotskruene. Maskinen må stå absolutt fast på grunnen. Ved glatte gulv skal det benyttes gummihetter under maskinens føtter.

Alle komponentgrupper og pluggforbindelser skal kontrolleres med hensyn til om de sitter godt. Spesielle jordlederforbindelser for alle berørbare metalldele skal kontrolleres av en elektro-fagmann med hensyn til om de sitter godt!

Slå av hovedbryteren. Nettstøpselet skal først tilkoples etter at alle punktene ovenfor er kontrollert.

Slå på hovedbryteren. Ved unormale lyder, røyk eller uvanlig lukt etter innkopling, skal nettstøpselet frakoples stikkontakten øyeblikkelig og en elektro-fagmann konsulteres. I et tvilstilfelle er det absolutt nødvendig å ta kontakt med forhandleren.



ADVARSEL !! Brannfare

Ikke under noen omstendigheter må den defekte maskinen fortsette å være i drift i denne tilstanden.

4.4. Innstillinger

Program- hhv. modellrelaterte innstillinger er oppført i den medleverte original-håndboken.



ADVARSEL !! Fare for elektrisk støt

Det er absolutt nødvendig å overholde sikkerhetsinstruksene i kapittel 2.

I et tvilstilfelle er det absolutt nødvendig å innhente sakkyndig hjelp hos forhandleren!

5. Inspeksjon, vedlikehold og pleie

5.1. Generelle informasjoner



ADVARSEL !! Fare for elektrisk støt

Det er absolutt nødvendig å overholde sikkerhetsinstruksene i kapittel 2.

Nettkabelens tilstand skal kontrolleres med regelmessige mellomrom. Hvis kabelen eller nettstøpselet er skadet, skal maskinen omgående settes ut av drift og repareres av en elektro-fagmann.

Det er absolutt nødvendig å kontrollere advarselene med hensyn til om de foreligger og er leselige, om nødvendig må de skiftes ut (se kapittel 8).

5.2. Vedlikehold

Selve maskinen er vedlikeholdsfri.

5.3. Rengjøring av huset og av den ytre skjermen

1. Slå av maskinen og kople fra nettstøpselet!
2. Rengjør huset og den ytre skjermen med en myk, fuktet (ikke våt) klut og mildt rengjøringsmiddel (det må ikke benyttes løsemiddel-, syre- eller skuremiddelholdige rengjøringsmidler).

6. Service

6.1. Generelle informasjoner



ADVARSEL !! Fare for elektrisk støt

Det er absolutt nødvendig å overholde sikkerhetsinstruksene i kapittel 2.

Ved en defekt skal nettstøpselet øyeblikkelig frakoples stikkontakten og reparasjonen skal kun utføres av en elektro-fagmann. Se serviceinstrukser i original-håndboken.

I et tvilstilfelle er det absolutt nødvendig å innhente sakkyndig hjelp hos forhandleren!

6.2. Utskiftning av defekte belysningslegemer

1. Slå av maskinen og kople fra nettstøpselet!
2. Forsiktig, belysningslegemet kan være varmt!
3. Belysningslegemet må kun skiftes ut mot foreskrevne deler. Se serviceinstrukser i original-håndboken.

7. Maskinen settes ut av drift

7.1. Generelle informasjoner



ADVARSEL !! Fare for elektrisk støt

Det er absolutt nødvendig å overholde sikkerhetsinstruksene i kapittel 2.

7.2. Demontasje

Nettstøpselet frakoples. Alle tilbehørsdeler som er beskrevet i kapittel 4.2 skal demonteres i omvendt rekkefølge. Sikre hodedelen under demontasjonen ved hjelp av minst 2 medhjelpere.

7.3. Flytting

Omtransport og gjenidriftsettelse utføres som beskrevet i kapittel 4.

7.4. Avfallsbehandling

Maskinen skal avfallsbehandles av et godkjent spesialfirma.

8. Advarsler

Advarsler, i tekst eller bilder, som klistremerker, påtrykt og/eller i form av denne brukerveiledningen, er selvsagt utsatt for slitasje. Operatøren bærer ansvaret for at disse foreligger og alltid er i leselig stand.

Skadede eller manglende advarsler skal erstattes omgående. Ta om nødvendig kontakt med forhandleren.

Brukerveiledningen må under enhver omstendighet oppbevares på et sikkert sted for senere bruk!

INHOUDSOPGAVE

- 1 Voorwoord**
EG-verklaring van overeenstemming
- 2. Veiligheidsaanwijzingen**
 - 2.1. Begripsbepaling
 - 2.2. Algemene toelichting
 - 2.3. Principiële veiligheidsaanwijzingen
- 3. Controle van het toestel**
 - 3.1. Controle na de levering
- 4. Transport, opstelling en inbedrijfstelling**
 - 4.1. Keuze van de opstellingsplaats en transport
 - 4.2. Opstelling en montage
 - 4.2.1. Video-balietoestel
 - 4.2.2. Montageaanwijzingen voor video-standtoestel en videotoestel met zitplaats
 - 4.2.2.1. Video-standtoestel leverborm
 - 4.2.2.2. Videotoestel met zitplaats leverborm
 - 4.3. Inbedrijfstelling
 - 4.4. Instellingen
- 5. Inspectie, onderhoud en behandeling**
 - 5.1. Algemene aanwijzingen
 - 5.2. Onderhoud
 - 5.3. Reinigen van het huis en het buitenste beeldscherm
- 6. Service**
 - 6.1. Algemene aanwijzingen
 - 6.2. Vervanging van defecte verlichtingselementen
- 7. Buitenwerkingstelling**
 - 7.1. Algemene aanwijzingen
 - 7.2. Demontage
 - 7.3. Verplaatsing
 - 7.4. Als afval verwijderen
- 8. Waarschuwingen**

1. Voorwoord

Deze gebruiksaanwijzing geldt voor videospeelautomaten op de balie, standautomaten en automaten met zitplaats. Reserveonderdeelnummers, serviceaanwijzingen en instellingen, zie apart bijgesloten origineel handboek. In geval van twijfel vooral ook bij problemen met het begrijpen van de taal of andere problemen met het originele handboek in elk geval de vakkundige hulp van uw dealer inroepen

EG-verklaring van overeenstemming

Dit toestel voldoet aan de veiligheidsrichtlijnen en standaards. Het apparaat valt niet onder de machinerichtlijn.

2. Veiligheidsaanwijzingen

2.1. Begripsbepaling



WAARSCHUWING!! Niet-inachtneming kan personenschade of dodelijk letsel ten gevolg hebben.

2.2. Algemene toelichting

Ingrepen aan het apparaat alleen door elektriciens anders bestaat er gevaar voor letsel alsmede gevaar voor een duurzame beschadiging.

Het gevolg hiervan zijn dure reparaties, vervanging van systeemcomponenten, vervallen van de aanspraak op garantie.

Installatie- en reparatiewerkzaamheden mogen alleen door een elektricien, servicewerkzaamheden alleen door opgeleid personeel plaatsvinden. De eigenaar van het toestel moet ervoor zorgen dat alle personen die met de opstelling, inbedrijfstelling, onderhoud, reparatie en instandhouding van het apparaat te maken hebben, overeenkomstig gekwalificeerd zijn en voor het begin van het werk de noodzakelijke veiligheidsinstructies en de bijbehorende hoofdstukken van het handboek gelezen en begrepen hebben.

De gebruiksaanwijzing absoluut op een veilige plaats voor later gebruik bewaren.

Bij onvakkundig hanteren, niet-reglementaire toepassing en eigenmachtige verbouwingen bestaat er geen aanspraak voor ongevallen, letsel en beschadigingen. Eigenmachtige verbouwingen en veranderingen van de automaat zijn om veiligheidsredenen uitdrukkelijk verboden.

Bij verdere vragen of in geval van twijfel contact met uw dealer opnemen.

De veiligheidsaanwijzingen moeten streng worden nageleefd. Het gaat om uw veiligheid.

2.3. Principiële veiligheidsaanwijzingen

Het apparaat mag alleen in werking gesteld worden wanneer de opstelling volgens de voorschriften en in overeenstemming met het handboek heeft plaatsgevonden.

Bedrijfsspanning en frequentie van het apparaat moet overeenstemmen met de netspanning en -frequentie. Elektrische gegevens zie typeplaatje op de achterzijde van het toestel. Apparaat alleen op behoorlijk geïnstalleerd, beveiligd en geaard stopcontact aansluiten.

Opstelling en inbedrijfstelling alleen in gesloten, droge ruimten. Apparaat mag alleen commercieel worden toegepast.

Beschadigde of ontbrekende waarschuwingaanwijzingen op het toestel moeten onmiddellijk worden vervangen.



WAARSCHUWING!! Implosiegevaar van de beeldbuizen en neonbuizen

Opstelling alleen op stabiele draagkrachtige ondergrond evt. bevestigen. Omvallen toestel kan de implosie van beeldbuizen of neonbuizen ten gevolg hebben. Rondvliegende glasscherven kunnen ernstig letsel veroorzaken.



WAARSCHUWING!! Gevaar door elektrische schokken

Voor het openen van het apparaat altijd de stekker uit het stopcontact trekken! Stekker nooit met natte handen aanraken. Achterwand van het toestel mag alleen door een elektricien geopend worden. Levensgevaarlijke aanraakbare hoogspanning in het inwendige van het toestel die ook na het eruit trekken van de stekker aanwezig zijn. Niet-inachtneming kan dodelijk of ernstig letsel veroorzaken.



WAARSCHUWING!! Brandgevaar

Zekeringen alleen door voorgeschreven zekeringen vervangen. Ventilatiesleuven van de speelautomaat nooit blokkeren. De omgevingstemperatuur mag 40°C niet overschrijden. Stroomcircuit en toevoerleidingen niet overbelasten.

Bij defect onmiddellijk de stekker uit het stopcontact trekken en reparatie alleen door elektriciens laten uitvoeren. Alleen aan de stekker, niet aan het snoer trekken.

Steekverbindingen in het inwendige van het toestel, in het geval van het zoeken naar een fout nooit onder spanning eruit trekken of erop steken. Reparatie principieel in spanningsloze toestand!

Alleen originele reserveonderdelen gebruiken.

Niet opvolgen van de bovengenoemde punten kan levensgevaarlijk zijn.

3. Controle van het toestel

3.1. Controle na de levering

Apparaat direct na de levering op transportschade onderzoeken. Zichtbare beschadigingen op de leverantiebewijs van de leverende expediteur noteren of direct na ontvangst van de goederen melden om uw aanspraken veilig te stellen.

Toestel openen en alle bouwgroepen en steekverbindingen op correct zitten controleren. Bijgesloten montage materiaal uit het inwendige van het toestel of de kassabox nemen. Wanneer de stekker niet overeenkomt met de in het desbetreffende land voorgeschreven norm, de passende stekker aan de netkabel aansluiten.



WAARSCHUWING!! Gevaar door elektrische schokken

Aansluiten van de netstekker alleen door erkende elektriciens. Bij niet-inachtneming brengt u zichzelf en anderen in gevaar.

Indien aanwezig, apart hoofdgedeelte of ziteenheid uit de verpakking nemen. Montage van deze delen pas op de opstellingsplaats, anders evt. beschadiging tijdens het transport.

4. Transport, opstelling en inbedrijfstelling

4.1. Keuze van de opstellingsplaats en transport

Opstelling en inbedrijfstelling alleen binnen gesloten, droge ruimten! Opstelling in de open lucht of in vochtige/natte ruimten is streng verboden. Binnendringend vocht kan ongevallen door elektrische schokken of fouten in het apparaat veroorzaken. Directe zonbestraling vermijden.

Transportwegen en -mogelijkheden op de opstellingsplaats voor het transport controleren. Bij apparaten met transportrollen bijzonder voorzichtig te werk gaan bij hellende ondergrond.

Apparaat alleen met voldoende aantal personen bewegen. Voorzichtig bij lager hangende verlichtingselementen.

Apparaat op gelijkmatige draagkrachtige ondergrond plaatsen. Ventilatieopeningen aan de achterzijde van het toestel niet blokkeren. Voldoende wandafstand (min. 10 cm) aanhouden.

Apparaat niet in de nabijheid van:

- a) levensreddende inrichtingen zoals bijv.
 - nooduitgangen
 - brandblussers enz.
- b) containers met licht ontvlambare stoffen, water of chemicaliën
- c) warmtebronnen zoals bijv.
 - verwarmingselementen
 - openingen van airconditioning
 - etalages met directe zonnebestraling enz.plaatsen.

Apparaat niet blootstellen aan belasting die tot functiestoring of defect leidt zoals bijv. sterke vibratie

- extreme stof- of vuilbelasting
- directe zonnebestraling of hitte
- regen of vochtigheid
- sterk magnetisme of radiogolven

Direkt op de opstellingsplaats van het toestel moet een behoorlijk geïnstalleerd, geaard, beveiligd stopcontact aanwezig zijn.

Het stroomcircuit waaraan het apparaat is aangesloten, niet overbelasten.

Netkabel zodanig leggen dat niemand erover struikelt. Niet-inachtneming kan ernstig letsel of beschadiging van het kabel ten gevolg hebben.

Netkabel niet scherp knikken of zware voorwerpen erop zetten anders beschadiging van de isolatie met als mogelijk gevolg aanraakbare netspanning, kortsluiting en daardoor brand.

4.2. Opstelling en montage

Apparaat plaatsen, stekker er niet insteken, pas nadat de opstelling afgesloten is.



WAARSCHUWING!! Implosiegevaar van de beeldbuis en neonbuizen

Absoluut de veiligheidsaanwijzingen in hoofdstuk 2.3 inachtnemen.

4.2.1. Video-baliestoestellen worden compleet gemonteerd geleverd. Geen verdere montage noodzakelijk. Voor veilige standplaats zorgen.

4.2.2. Montageaanwijzingen voor video-standtoestel en videotoestel met zitplaats

Wanneer aanwezig, aparte accessoires veilig met de in het bijgesloten pak aanwezige schroeven aan het apparaat bevestigen. Hoofdgedeelte tijdens de montage door tenminste twee hulpkrachten laten beveiligen, opstapje bijv. ladder of trapje gebruiken. indien aanwezig, steekverbindingen van de accessoires erop steken.

Veiligheidsaarddraadverbindingen veilig tot stand brengen.

Montage-aanwijzingen, zie origineel handboek.

In geval van twijfel in elk geval de vakkundige hulp van uw dealer gebruiken.

4.2.2.1. Video-standtoestel, leverborm

- a) compleet gemonteerd en/of
- b) met apart ingepakt hoofdgedeelte (verlicht of niet verlicht) en/of
- c) met apart verpakte bedieningseenheid

4.2.2.2. Videotoestel met zitplaats, mogelijke leverbormen

- a-c) net als video-standtoestel en/of extra
- d) met apart verpakte ziteenheid

4.3. Inbedrijfstelling

Indien aanwezig, met hoogte verstelbare voetschroeven het toestel precies nivelleren. Het toestel moet absoluut stevig op de ondergrond staan. Bij gladde vloerbedekking rubberen doppen onder de voeten van het toestel gebruiken.

Alle bouwgroepen en steekverbindingen op vast zitten controleren. Bijzonder verbindingen van veiligheidsaarddraad van alle aanraakbare metalen onderdelen door een elektricien op vast zitten laten controleren.

Hoofdschakelaar uitschakelen. Stekker pas na het controleren van alle bovengenoemde punten erin steken.

Hoofdschakelaar inschakelen. Bij niet normaal geluid, rook of ongewone geur na het inschakelen onmiddellijk de stekker uit het stopcontact trekken en elektricien te hulp roepen. In geval van twijfel in elk geval contact opnemen met uw dealer.



WAARSCHUWING!! Brandgevaar

Het toestel in geen geval in defecte toestand gebruiken

4.4. Instellingen

Instellingen m.b.t. het programma c.q. model staan vermeld in het bijgesloten originele handboek.



WAARSCHUWING!! Gevaar door elektrische schokken

In elk geval de veiligheidsinstructies in hoofdstuk 2 inacht nemen

In geval van twijfel in elk geval de vakkundige hulp van uw dealer inroepen.

5. Inspectie, onderhoud en behandeling

5.1. Algemene aanwijzingen



WAARSCHUWING!! Gevaar door elektrische schokken

In elk geval de veiligheidsinstructies in hoofdstuk 2 inacht nemen

Toestand van de stekker regelmatig controleren. Bij beschadigde kabel of netstekker apparaat onmiddellijk buiten werking stellen en door elektricien laten repareren.

In elk geval de waarschuwingaanwijzingen op aanwezig zijn en leesbaarheid controleren evt. vervangen (zie hoofdstuk 8).

5.2. Onderhoud

Het apparaat zelf is onderhoudsvrij.

5.3. Reinigen van het huis en het buitenste beeldscherm

1. Toestel uitschakelen en stekker eruit trekken.
2. Huis en buitenste beeldscherm met zachte vochtige doek (niet nat) en mild reinigingsmiddel reinigen (geen oplosmiddel-, zuur- of schuurmiddelhoudende reinigingsmiddelen gebruiken).

6. Service

6.1. Algemene aanwijzingen



WAARSCHUWING!! Gevaar door elektrische schokken

In elk geval de veiligheidsinstructies in hoofdstuk 2 inachtnemen

Bij defect netstekker er onmiddellijk uittrekken en reparatie door elektriciens laten uitvoeren. Serviceaanwijzingen, zie origineel handboek.

In geval van twijfel in elk geval de vakkundige hulp van uw dealer inroepen.

6.2. Vervanging van defecte verlichtingselementen

1. Toestel uitschakelen en stekker eruit trekken.
2. Voorzichtig, verlichtingselement kan heet zijn.
3. Verlichtingselementen alleen door voorgeschreven onderdelen vervangen. Serviceaanwijzingen, zie origineel handboek.

7. Buitenwerkingstelling

7.1. Algemene aanwijzingen



WAARSCHUWING!! Gevaar door elektrische schokken

In elk geval de veiligheidsinstructies in hoofdstuk 2 inachtnemen

7.2. Demontage

Stekker eruit trekken. Alle in hoofdstuk 4.2. beschreven originele accessoires in omgekeerde volgorde demonteren. Hoofdgedeelte tijdens de demontage door tenminste twee hulpkrachten laten beveiligen.

7.3. Verplaatsing

Verplaatsing en hernieuwde inbedrijfstelling uitvoeren zoals beschreven in hoofdstuk 4.

7.4. Als afval verwijderen

Door toegelaten vakbedrijven laten verwijderen.

8. Waarschuwingen

Waarschuwingaanwijzingen in de tekst of afbeelding opschrift en /of in vorm van deze gebruiksaanwijzing zijn onderhevig aan natuurlijke slijtage. De exploitant draagt de verantwoordelijkheid dat deze aanwezig en leesbaar zijn.

Beschadigde of ontbrekende aanwijzingen moeten onmiddellijk worden vervangen. Neem indien noodzakelijk contact op met uw dealer.

Gebruiksaanwijzing in elk geval op een veilige plaats voor later gebruik bewaren.

ÍNDICE

1. **Introdução**
Declaração conforme as leis vigentes na CE
2. **Instruções de segurança**
 - 2.1. Conceito
 - 2.2. Esclarecimento geral
 - 2.3. Instruções de Segurança Elementares
3. **Controlo do equipamento**
 - 3.1. Controlo depois da entrega
4. **Transporte, Instalação e Colocação em funcionamento**
 - 4.1. Escolha do Local de Instalação e Transporte
 - 4.2. Instalação e Montagem dos Aparelhos
 - 4.2.1. Consola Vídeo de parede
 - 4.2.2. Montagem de Consolas Vídeo com e sem assento
 - 4.2.2.1. Consola Vídeo Vertical. Forma de Fornecimento
 - 4.2.2.2. Consola Vídeo com Assento. Forma de Fornecimento
 - 4.3. Colocação em Serviço
 - 4.4. Ajustação
5. **Inspeção, Manutenção e Limpeza**
 - 5.1. Considerações Gerais
 - 5.2. Manutenção
 - 5.3. Limpeza da Caixa Exterior e do Écran
6. **Assistência**
 - 6.1. Considerações Gerais
 - 6.2. Substituição das Lâmpadas de Iluminação quando estragadas
7. **Retirar de Serviço**
 - 7.1. Considerações Gerais
 - 7.2. Desmontagem
 - 7.3. Deslocamento
 - 7.4. Reciclagem
8. **Aviso de Precaução**

1. Introdução

Estas instruções de serviço são válidas para as máquinas de jogo-vídeo para parede e de consola, com e sem assento. Ver no manual de origem fornecido as indicações relativas a peças sobresselentes, instruções de manutenção e regulação do equipamento. Em caso de dúvida na leitura do manual de origem, por dificuldade de compreensão linguística ou outra, solicitar a ajuda do fornecedor impreterivelmente!

O direito da alteração deste manual por nova edição é mantido.

Declaração conforme as leis vigentes na CE

Este equipamento está conforme as directivas de segurança e normas europeias. Não é abrangido pelas directivas comunitárias para máquinas.

2. Instruções de segurança

2.1. Conceito



AVISO !!

A não observância destas instruções pode provocar danos físicos ou ferimentos mortais.

2.2. Esclarecimento geral

O manuseamento do aparelho deve ser efectuado unicamente por pessoal especializado em electricidade, sob pena de perigo de ferimentos ou danos físicos permanentes. Como consequência ter-se-ão reparações mais caras, substituição de componentes do sistema e perda do direito à garantia.

Os trabalhos de instalação e reparação só devem ser efectuados por electricista especializado, os trabalhos de assistência por pessoal com formação adequada. O proprietário deste aparelho deve assegurar-se que qualquer trabalho de montagem, ligação, manutenção, reparação e conservação do equipamento é efectuado por pessoal qualificado que antes do início dos trabalhos leu e compreendeu as necessárias medidas de segurança e os capítulos do manual respeitantes às tarefas a efectuar.

As instruções de serviço devem ser colocadas impreterivelmente em local seguro para utilização futura.

Em caso de manuseamento impróprio, utilização contrária ao determinado ou reconstrução arbitrária, não é assumida qualquer responsabilidade em caso de acidente, ferimento ou prejuízo. Reconstrução arbitrária ou alteração dos equipamentos são proibidas por razões de segurança.

Para mais esclarecimentos ou em caso de dúvida contactar o fornecedor.

As normas de segurança são para serem exactamente cumpridas ! Está em jogo a sua segurança.

2.3. Instruções de segurança elementares

O equipamento só deve ser posto em serviço depois de montado e verificado cuidadosamente segundo as indicações do manual.

A tensão e frequência de serviço para o aparelho devem corresponder à tensão e frequência da rede. Os dados eléctricos encontram-se na chapa na parte de trás do equipamento. O aparelho só deve ser ligado a uma tomada de corrente bem instalada, protegida e ligada à terra.

A colocação e utilização do equipamento só devem ser efectuadas em quarto fechado e seco. O equipamento só pode ser utilizado industrialmente.

As chapas de aviso devem ser imediatamente substituídas em caso de danos ou de falta.



AVISO !! Perigo de implosão do tubo de raios catódicos e das lâmpadas de néon

Instalar e segurar o equipamento só em superfície estável e com capacidade de carga apropriada. Um equipamento instável pode provocar a implosão do tubo de raios catódicos ou das lâmpadas de néon. Os pedaços de vidro resultantes da implosão podem provocar ferimentos muito graves.



AVISO !! Perigo de choque eléctrico

Antes de abrir o equipamento, retirar sempre a ficha da tomada eléctrica. Nunca mexer na tomada com as mãos húmidas. O painel anterior só deve ser aberto por um electricista especializado. A alta tensão remanescente que permanece no interior do equipamento mesmo depois de desligado é mortal. A falta de atenção pode provocar ferimentos graves ou mortais.



AVISO !! Perigo de incêndio

A protecção eléctrica só pode ser substituída pela recomendada. As aberturas de respiração do aparelho nunca devem ser bloqueadas. A temperatura ambiente não deve ultrapassar os 40°C. As cargas da rede e dos condutores não devem ser sobrecarregadas.

Em caso de avaria, retirar imediatamente a tomada da ficha e efectuar a reparação só por electricista especializado. Puxar pela ficha, nunca pelo cabo.

Na pesquisa da avaria, nunca ligar ou desligar em tensão as fichas internas do equipamento. Por princípio, a reparação deve ser efectuada sem corrente!

Utilizar unicamente peças sobresselentes originais.

O não cumprimento das regras acima descritas pode ter consequências mortais!

3. Controlo do equipamento

3.1. Controlo depois da entrega

A pesquisa de danos de transporte deve ser efectuada imediatamente após a sua recepção. Anotar imediatamente na folha de carga da transportadora os danos visíveis ou durante o acto de recepção, para assegurar os seus direitos.

O equipamento deve ser aberto e todos os elementos de construção e fichas de ligação verificados no respeito à rigidez de montagem.

Retirar do interior do equipamento ou caixa adjunta os materiais de montagem complementares.

No caso da ficha eléctrica não corresponder às normas existentes no país de destino, montar uma ficha apropriada no cabo de ligação.



AVISO !! Perigo de choque eléctrico

Só um electricista especializado deve montar a ficha. O não cumprimento desta medida de segurança põe em perigo você e os outros!

Caso exista, retirar a parte superior e o assento da embalagem. Fazer a montagem destes só no local escolhido, pois podem-se danificar durante o transporte.

4. Transporte, Instalação e Colocação em funcionamento

4.1. Escolha do local e transporte

A colocação e utilização do equipamento só em quarto fechado e seco. A colocação ao ar livre ou em ambiente húmido ou molhado é estritamente proibida. A existência de humidade

no interior do equipamento pode provocar acidentes através de choque eléctrico ou erros de funcionamento do aparelho. Evitar os raios solares directos.

Verificar primeiro o caminho e o lugar de colocação. Com equipamentos providos com rodas de transporte, tomar especial atenção a caminhos íngremes.

Deslocar o equipamento utilizando o número de pessoas necessárias. Tomar atenção com a existência de lâmpadas baixas.

Colocar o equipamento em superfície nivelada e de carga apropriada. Não tapar as aberturas para o ar na parte de trás. Afastar da parede o equipamento (min. 10 cm).

Não colocar o equipamento na proximidade de:

- a) equipamentos de segurança, i.e.:
 - saídas de emergência,
 - extintores, etc..
- b) contentores com substâncias facilmente inflamáveis, água ou produtos químicos.
- c) corpos quentes, i.e.:
 - aquecedores,
 - aberturas da instalação do ar condicionado,
 - montras directas ao sol, etc..

Não colocar os equipamentos em condições que possam provocar avarias ou defeitos de funcionamento, i.e.:

- vibrações fortes,
- muita sujidade ou pó,
- raios de sol directos ou aquecimento,
- chuva ou humidade,
- forte magnetismo ou ondas electromagnéticas.

Junto ao local de instalação deve existir uma tomada eléctrica devidamente instalada, protegida e ligada à terra.

A carga do circuito eléctrico utilizado para o aparelho não deve ser ultrapassada.

O cabo eléctrico deve ser instalado de modo que não se possa tropeçar nele. O não cumprimento desta medida de segurança pode ocasionar ferimentos e/ou danos no cabo.

Não vincar o cabo eléctrico nem colocar pesos em cima dele, sob pena de o isolamento ficar danificado e o condutor em carga ficar à vista, podendo ocasionar curto-circuitos e mesmo fogo.

4.2. Instalação e Montagem dos Aparelhos

Situar o equipamento. Não ligar à corrente antes de finalizar a instalação.



AVISO !! Perigo de implosão do tubo de raios catódicos e das lâmpadas de néon

Cumprir absolutamente as directivas de segurança do ponto 2.3.

4.2.1. As Consolas Vídeo de parede são fornecidos completamente montados. Nenhuma montagem adicional é necessária. Prover um lugar seguro!

4.2.2. Montagem de Consolas Vídeo vertical e vídeo com assento

As peças acessórias, caso existam, devem ser devidamente aparafusadas ao equipamento com os parafusos fornecidos. A parte superior necessita de dois ajudantes durante a montagem. Utilizar meios de elevação próprios, i.e., escada ou escadote. Caso existam, ligar as fichas do equipamento acessório.

Assegurar a ligação do condutor de protecção.

Para as instruções de montagem ver o manual de origem.

Em caso de dúvida, utilizar únicamente a ajuda competente do fornecedor!

4.2.2.1. Consola Vídeo Vertical, possíveis formas de fornecimento:

- a) Completamente montado e/ou
- b) com a parte superior em embalagem separada (com ou sem iluminação) e/ou
- c) com unidade de utilização em embalagem separada

4.2.2.2. Consola Vídeo com assento, possíveis formas de fornecimento:

- a-c) como para a Consola Vídeo Vertical e/ou como acessório
- d) com unidade de assento em embalagem separada

4.3. Colocação em serviço

Se for necessário, nivelar exactamente por meio dos pés roscados o equipamento. O equipamento deve ficar bem agarrado ao chão. Em piso escorregadio, utilizar capas de borracha nos pés do equipamento.

Todos os elementos de construção e ligações devem ser verificados quanto à rigidez. Em especial, as ligações à terra de todas as partes metálicas à vista devem ser verificadas por electricista especializado.

Desligar o interruptor geral. A ligação à corrente só depois de verificados todos os pontos anteriores.

Ligar o interruptor geral. No caso de aparecerem ruídos, fumos ou cheiros inesperados logo após a ligação, tirar rapidamente a ficha da tomada e consultar um electricista especializado. Em caso de dúvida, consultar impreterivelmente o fornecedor.



AVISO !! Perigo de incêndio

Em caso algum continuar a utilizar o equipamento enquanto defeituoso

4.4. Afinação

Utilizar as instruções do manual de origem para a afinação consoante o programa e modelo em causa



AVISO !! Perigo de choque eléctrico

Cumprir absolutamente as directivas de segurança do ponto 2.

Em caso de dúvida, impreterivelmente seguir o conselho especializado do fornecedor.

5. Inspeção, Manutenção e Limpeza

5.1. Considerações gerais



AVISO !! Perigo de choque eléctrico

Cumprir absolutamente as directivas de segurança do ponto 2.

Verificar o estado do cabo eléctrico regularmente. Em caso de danificação do cabo ou da ficha, desligar imediatamente o aparelho e mandar reparar por electricista especializado.

Verificar impreterivelmente a existência e a legibilidade da chapa de aviso do equipamento e substituí-la se necessário (ver Ponto 8).

5.2. Manutenção

O equipamento em si é livre de manutenção.

5.3. Limpeza da caixa exterior e do écran

1. Desligar o equipamento e retirar a ficha da tomada de corrente.
2. Limpar a caixa exterior do aparelho e o écran com um pano macio levemente humedecido (sem ser molhado) e com um detergente neutro (não usar produtos de limpeza tais como diluentes, ácidos ou abrasivos).

6. Assistência

6.1. Considerações gerais



AVISO !! Perigo de choque eléctrico

Cumprir absolutamente as directivas de segurança do ponto 2.

Em caso de avaria, desligar imediatamente o equipamento e retirar a ficha da tomada e proceder à reparação únicamente por electricista especializado. Para mais instruções ver o manual de origem.

Em caso de dúvida impreterivelmente seguir o conselho especializado do fornecedor.

6.2. Substituição das Lâmpadas de Iluminação quando estragadas

1. Desligar o equipamento e retirar a ficha da tomada!
2. Atenção, a lâmpada pode estar ainda quente!
3. Substituir a lâmpada de iluminação por outra devidamente aprovada. Para sugestões de serviço ver o manual de origem.

7. Retirar de serviço

7.1. Considerações gerais



AVISO !! Perigo de choque eléctrico

Cumprir absolutamente as directivas de segurança do ponto 2.

7.2. Desmontagem

Retirar a ficha da tomada. Todos os elementos acessórios descritos no ponto 4.2. devem ser desmontados em ordem inversa. A desmontagem da parte superior deve ser assistida por dois ajudantes.

7.3. Deslocamento

O transporte e nova instalação devem ser efectuadaa segundo as prescrições do ponto 4.

7.4. Reciclagem

O equipamento deve ser reciclado por uma firma especializada e autorizada.

8. Aviso de precaução

O texto e imagens das placas de aviso, sejam elas impressas ou em auto colante e/ou as páginas destas instruções sofrem um desgaste natural com o tempo. O encarregado local tem a responsabilidade sobre a existência e legibilidade dos mesmos.

As chapas de aviso em falta ou danificadas devem ser substituídas imediatamente. Em caso de necessidade, contactar o fornecedor.

As instruções de serviço devem ser colocadas impreterivelmente em local seguro para utilização futura.

INNEHÅLLSFÖRTECKNING

1. **Förord**
EG-försäkran om överensstämmelse
2. **Säkerhetsanvisningar**
 - 2.1. Begreppsdefinitioner
 - 2.2. Allmänna förklaringar
 - 2.3. Grundläggande säkerhetsanvisningar
3. **Apparatkontroll**
 - 3.1. Kontroll efter mottagningen
4. **Transport, uppställning och drifttagning**
 - 4.1. Val av uppställningsplats och transport
 - 4.2. Uppställning och montering
 - 4.2.1. TV-spel för bänkautomater
 - 4.2.2. Monteringsanvisningar för TV-spel i stå- och sittautomater
 - 4.2.2.1. TV-spel i ståautomater; leveransalternativ
 - 4.2.2.2. TV-spel i sittautomater; leveransalternativ
 - 4.3. Drifttagning
 - 4.4. Inställningar
5. **Inspektion, underhåll och service**
 - 5.1. Allmänna anvisningar
 - 5.2. Underhåll
 - 5.3. Rengöring av huset och den yttre bildskärmen
6. **Service**
 - 6.1. Allmänna anvisningar
 - 6.2. Byte av defekta lampor
7. **Urdrifttagning**
 - 7.1. Allmänna anvisningar
 - 7.2. Demontering
 - 7.3. Förflyttning
 - 7.4. Avfallshantering
8. **Varningstexter/-bilder**

1. Förord

Denna bruksanvisning gäller för TV-spel för bänk-, stå- och sittautomater. För reservdelsnummer, serviceanvisningar och inställningar, se den medföljande separata originalhandboken. Ta alltid kontakt med din återförsäljare om du är osäker på innehållet i originalhandboken, även vid språksvårigheter eller liknande.

Med förbehåll för ändringar genom nya upplagor av denna handbok.

EG-försäkran om överensstämmelse

Denna apparat överensstämmer med europeiska säkerhetsdirektiv och normer. Den berörs inte av maskindirektivet.

2. Säkerhetsanvisningar

2.1. Begreppsdefinitioner



WARNING !! Om säkerhetsanvisningarna inte följs kan detta leda till personskador eller skador med dödlig utgång!

2.2. Allmänna förklaringar

Arbeten på apparaten för endast utföras av elteknisk personal, i annat fall finns det risk för personskador eller bestående materiella skador. Följderna kan bli dyra reparationer, utbyte av systemkomponenter samt att garantin inte längre gäller.

Installations- och reparationsarbeten får endast utföras av elteknisk personal och servicearbeten endast av instruerad personal. Ägaren av denna apparat ansvarar för att alla personer som är inblandade i uppställning, drifttagning, underhåll och reparation av apparaten har de rätta kvalifikationerna och att de alltid har läst och förstått de nödvändiga säkerhetsanvisningarna och de tillhörande kapitlen i handboken.

Förvara alltid bruksanvisningen på ett säkert ställe för senare bruk.

Vi påtar oss inget ansvar för olyckor, personskador och materiella skador som uppträder till följd av felaktig användning eller egenmäktiga förändringar av apparaten.

Egenmäktiga ombyggnader eller förändringar av automaten är uttryckligen förbjudna av säkerhetsskäl.

Om du har ytterligare frågor eller är osäker om innehållet, ta kontakt med din återförsäljaren.

Säkerhetsanvisningarna skall följas till punkt och pricka. Det handlar om din säkerhet!

2.3. Grundläggande säkerhetsanvisningar

Ta endast apparaten i drift om den är uppställd enligt föreskrifterna och i överensstämmelse med handboken.

Apparatens driftspänning och -frekvens skall överensstämma med nätspänningen och -frekvensen. För elektriska data, se typskylten på apparatens baksida. Anslut endast apparaten till ett korrekt installerat, säkrat och jordat eluttag.

Ställ endast upp apparaten och ta den i drift i slutna och torra rum. Apparaten får endast användas yrkesmässigt.

Skadade eller saknade varningstexter/-bilder på apparaten skall genast ersättas.



VARNING !!

Implosionsrisk för bildrör och neonrör

Ställ endast upp apparaten på ett stabilt, bärkraftigt underlag och fäst den vid behov. Om apparaten välter kan bildröret eller neonröret implodera. Kringflygande glassplitter kan leda till svåra personskador.



VARNING !!

Risk för elektriska stötar

Innan apparaten öppnas skall stickkontakten ALLTID dras ut ur eluttaget. Rör aldrig vid stickkontakten med våta händer. Apparaten baksida får endast öppnas av elteknisk personal. Det förekommer livsfarlig, oskyddad högspänning inuti apparaten som ligger kvar även sedan stickkontakten dragits ur. Risk för dödsfall eller svåra personskador.



VARNING !!

Brandfara

Byt endast ut säkringar mot föreskrivna säkringar. Blockera aldrig spelautomatens luftintag. Omgivningstemperaturen får inte överstiga 40°C. Överbelasta inte nätet eller matningskablar.

Dra genast ut stickkontakten ur eluttaget vid fel och låt endast en eltekniker utföra reparationen. Dra i stickkontakten och inte i kabeln.

Dra aldrig ut eller stick in ett kontaktdon inuti apparaten vid felsökning när spänningen är tillslagen. Utför i princip reparationsarbetena när apparaten är spänningslös.

Använd endast original reservdelar!

Ovanstående punkter måste följas, annars finns risk för livshotande skador!

3. Apparatkontroll

3.1. Kontroll efter mottagningen

Undersök apparaten direkt när den mottagits för att konstatera ev. transportskador. Notera synliga skador på mottagningsbeviset från speditiionsfirman eller meddela dem omedelbart efter det att varorna mottagits, för att säkra era anspråk.

Öppna apparaten och kontrollera att alla moduler och kontaktdon sitter som de skall.

Ta ut medföljande monteringsmaterial från apparatens inre eller från myntboxen.

Om den medföljande stickkontakten inte överensstämmer med den nationella standarden, skall en passande stickkontakt anslutas till nätkabeln.



VARNING !!

Risk för elektriska stötar

Stickkontakten från endast anslutas till nätkabeln av en eltekniker. I annat fall riskerar man att skada sig själv och andra.

Ta först ut den eventuella separata huvuddelen eller sitheten ur förpackningen. Dessa delar skall monteras först på uppställningsplatsen, annars skadas de under transporten.

4. Transport, uppställning och drifttagning

4.1. Val av uppställningsplats och transport

Ställ endast upp apparaten och ta den i drift i slutna och torra rum. Uppställning i det fria eller i fuktiga/våta rum är strängt förbjuden. Inträngande fukt kan leda till olyckor genom elektriska stötar eller till fel inuti apparaten. Utsätt inte apparaten för direkt solstrålning.

Kontrollera transportvägar och -möjligheter till uppställningsplatsen innan transporten utförs.

Var särskilt försiktig på sluttande golv när apparaten förflyttas på transporttrullar.

När apparaten förflyttas skall ett tillräckligt antal personer delta i arbetet. Var försiktig vid lågt hängande belysningsarmaturer.

Ställ endast upp apparaten på ett stabilt, bärkraftigt underlag. Täck inte för luftintagen på apparatens baksida. Se till att hålla tillräckligt avstånd till väggen (ca 10 cm).

Placera inte apparaten i närheten av:

- a) livräddningsanordningar som t ex:
 - nödutgångar,
 - brandsläckare o s v;
- b) behållare med lättantändliga ämnen, vatten eller kemikalier;
- c) värmeelement, som t ex:
 - öppningar på klimatanläggningar,
 - skyltfönster med direkt solinstrålning o s v.

Utsätt inte apparaten för belastningar som kan leda till funktionsstörningar eller fel, som t ex:

- starka vibrationer,
- extrem belastning från damm eller smuts,
- direkt solinstrålning eller hög värme,
- regn eller fuktighet,
- stark magnetism eller radiovågor.

Vid uppställningsplatsen skall det finnas ett korrekt installerat, jordat och säkrat eluttag.

Överbelasta inte det strömnät som apparaten är ansluten till.

Dra nätkabeln på ett sådant sätt att ingen snubblar över den. I annat fall kan det leda till svåra personskador eller skador på nätkabeln.

Bocka inte nätkabeln eller ställ tunga föremål på den, för att inte skada isoleringen. I annat fall finns det risk för oskyddad nätspänning, kortslutning och därmed fara för brand.

4.2. Uppställning och montering av apparaten

Placera apparaten på uppställningsplatsen och stick ännu inte in stickkontakten i eluttaget. Detta görs när uppställningen är helt avslutad.



WARNING !!

Implosionsrisk för bildrör och neonrör

Säkerhetsanvisningarna i avsnitt 2.3 måste ovillkorligen följas!

4.2.1. TV-spel för bänkautomater levereras komplett monterade. Ingen ytterligare montering är nödvändig. Se till att apparaten står säkert.

4.2.2. Monteringsanvisningar för TV-spel i stå- och sittautomater

Fäst ev. separata tillbehör delar säkert på apparaten med skruvarna i den medföljande förpackningen. Huvuddelen skall hållas fast av minst två medhjälpare under monteringen; använd stege eller pall. Anslut ev. kontaktdon på tillbehör delarna.

Upprätta säkra skyddsledarförbindelser.

För monteringsanvisningar, se originalhandboken.

Om du är osäker, ta alltid kontakt med din återförsäljare.

4.2.2.1. TV-spel i ståautomater; leveransalternativ:

- a) komplett monterad och/eller
- b) med separat medföljande huvudel (med eller utan belysning) och/eller
- c) med separat medföljande manöverenhet.

4.2.2.2. TV-spel i sittautomater; leveransalternativ:

- a–c) som för ståautomater och/eller
- c) med separat medföljande sittenhet.

4.3. Drifttagning

Nivellera apparaten exakt med hjälp av de justerbara fotskruvarna. Apparaten måste stå helt stadigt på underlaget. Sätt gummiskydd på apparatfötterna om golvet är halt.

Kontrollera att alla moduler och kontaktdon sitter säkert. Särskilt skall skyddsledarna till alla åtkomliga metalldelar kontrolleras av en eltekniker.

Slå från nätströmbrytaren. Stick in stickkontakten först sedan alla de ovanstående punkterna kontrollerats.

Slå till nätströmbrytaren. Vid onormalt ljud, lukt eller rökbildning efter inkopplingen skall stickkontakten genast dras ut ur eluttaget och en eltekniker kontaktas. Om du är osäker, kontakta alltid din återförsäljare.



VARNING !! Brandfara

Den defekta apparaten får under inga omständigheter tas i bruk.

4.4. Inställningar

För inställningar beroende på olika program och modeller, se den medföljande originalhandboken.



VARNING !! Risk för elektriska stötar

Säkerhetsanvisningarna i avsnitt 2 måste ovillkorligen följas!

Om du är osäker, kontakta alltid din återförsäljare.

5. Inspektion, underhåll och service

5.1. Allmänna anvisningar



VARNING !! Risk för elektriska stötar

Säkerhetsanvisningarna i avsnitt 2 måste ovillkorligen följas!

Kontrollera nätkabelns skick regelbundet. Om kabeln eller stickkontakten är skadade skall apparaten genast tas ur drift och repareras av en eltekniker.

Kontrollera ovillkorligen att varningstexterna/-bilderna är på plats och är läsbara, byt ut dem vid behov (se avsnitt 8).

5.2. Underhåll

Själva apparaten är underhållsfri.

5.3. Rengöring av huset och den yttre bildskärmen

1. Slå från apparaten och dra ut stickkontakten ur eluttaget.
2. Rengör huset och den yttre bildskärmen med en mjuk, fuktig (ej våt) duk och ett mildt rengöringsmedel (inget syrehaltigt rengöringsmedel eller rengöringsmedel som innehåller lösningsmedel eller slipmedel).

6. Service

6.1. Allmänna anvisningar



VARNING !! Risk för elektriska stötar

Säkerhetsanvisningarna i avsnitt 2 måste ovillkorligen följas!

Vid fel skall stickkontakten genast dras ut ur eluttaget och apparaten repareras av en eltekniker. För serviceanvisningar, se originalhandboken.

Om du är osäker, ta alltid kontakt med din återförsäljare.

6.2. Byte av defekta lampor

1. Slå från apparaten och dra ut stickkontakten ur eluttaget.
2. Var försiktig; lamporna kan vara heta.
3. Byt endast ut lamporna mot föreskrivna reservdelar. För serviceanvisningar, se originalhandboken.

7. Urdrifftagning

7.1. Allmänna anvisningar



VARNING !! Risk för elektriska stötar

Säkerhetsanvisningarna i avsnitt 2 måste ovillkorligen följas!

7.2. Demontering

Dra ut stickkontakten ur eluttaget. Demontera alla tillbehörsdelarna i avsnitt 4.2 i omvänd ordningsföljd. Huvuddelen skall hållas fast av minst två medhjälpare under demonteringen.

7.3. Förflyttning

Förflyttning och ny drifftagning skall göras såsom beskrivs i avsnitt 4.

7.4. Avfallshantering

Låt ett godkänt avfallsföretag ta hand om den uttjänta apparaten.

8. Varningstexter/-bilder

Varningstexter eller -bilder i form av etiketter, tryck och/eller i denna bruksanvisning utsätts för naturligt slitage. Användaren ansvarar för att de finns tillhands och är läsbara.

Skadade eller saknade varningstexter/-bilder skall genast ersättas. Kontakta vid behov din återförsäljare.

Förvara alltid bruksanvisningen på ett säkert ställe för senare bruk.

ΠΕΡΙΕΧΟΜΕΝΑ

1. **Πρόλογος**
Δήλωση Ανταπόκρισης Ε.Ε.
2. **Υποδείξεις ασφαλείας**
 - 2.1. Ορισμός έννοιας
 - 2.2. Γενικές εξηγήσεις
 - 2.3. Βασικές υποδείξεις ασφαλείας
3. **Ελεγχος συσκευής**
 - 3.1. Έλεγχος μετά την παράδοση
4. **Μεταφορά, εγκατάσταση και θέση λειτουργίας**
 - 4.1. Επιλογή τόπου εγκατάστασης και μεταφορά
 - 4.2. Εγκατάσταση και συναρμολόγηση
 - 4.2.1. Συσκευή Video μπαρ
 - 4.2.2. Οδηγίες εγκατάστασης ως ορθή συσκευή Video και καθιστή συσκευή Video
 - 4.2.2.1. Ορθή συσκευή Video, τύπος παράδοσης
 - 4.2.2.2. Καθιστή συσκευή Video, τύπος παράδοσης
 - 4.3. Θέση λειτουργίας
 - 4.4. Ρυθμίσεις
5. **Έλεγχος, συντήρηση και φροντίδα**
 - 5.1. Γενικές οδηγίες
 - 5.2. Συντήρηση
 - 5.3. Καθάρισμα πλαισίου και εξωτερικής οθόνης
6. **Σέρβις**
 - 6.1. Γενικές οδηγίες
 - 6.2. Αντικατάσταση χαλασμένων σωμάτων φωτισμού
7. **Θέση εκτός λειτουργίας**
 - 7.1. Γενικές οδηγίες
 - 7.2. Αποσυναρμολόγηση
 - 7.3. Μετατόπιση
 - 7.4. Απομάκρυνση
8. **Προειδοποιητικές υποδείξεις**

1. Πρόλογος

Οι παρούσες οδηγίες λειτουργίας ισχύουν για ηλεκτρονικές συσκευές βιντεοπαιχνιδιών μπαρ, καθιστές ή ορθές. Νούμερα παραγγελίας ανταλλακτικών, οδηγίες σέρβις και ρυθμίσεις βλέπε στο ξεχωριστό συνημμένο γνήσιο εγχειρίδιο λειτουργίας. Σε περίπτωση αμφιβολιών, ιδιαίτερα σε δυσκολίες συνεννόησης γλωσσικής ή άλλης μορφής με το γνήσιο εγχειρίδιο λειτουργίας, να ζητάτε οπωσδήποτε την ειδική βοήθεια του αντιπροσώπου σας!

Διατηρούμε το δικαίωμα αλλαγών του παρόντος εγχειριδίου σε νέες εκδόσεις.

Δήλωση Ανταπόκρισης Ε.Ε.

Η συσκευή αυτή ανταποκρίνεται στις ευρωπαϊκές Οδηγίες Ασφαλείας και Πρότυπα. Δεν υπόκειται στην Οδηγία περί Μηχανών.

2. Υποδείξεις ασφαλείας

2.1. Ορισμός έννοιας



ΠΡΟΣΟΧΗ !!

Η μη τήρηση των οδηγιών μπορεί να προκαλέσει σωματικές βλάβες ή θανατηφόρους τραυματισμούς.

2.2. Γενικές εξηγήσεις

Επεμβάσεις στη συσκευή επιτρέπεται να γίνονται μόνο από ειδικό ηλεκτρολόγο, διαφορετικά υπάρχει κίνδυνος τραυματισμού ή διαρκούς βλάβης της συσκευής. Οι συνέπειες θα ήταν ακριβές επισκευές, αντικαταστάσεις εξαρτημάτων του συστήματος, εξάλειψη των δικαιωμάτων εγγύησης.

Οι εργασίες εγκατάστασης και επισκευής πρέπει να εκτελούνται μόνο από ε ι δ ι κ ό ηλεκτρολόγο, εργασίες σέρβις μόνο από ενημερωμένο προσωπικό. Ο ιδιοκτήτης αυτής της συσκευής πρέπει να είναι σίγουρος ότι όλα τα άτομα που έχουν να κάνουν με την εγκατάσταση, θέση λειτουργίας, φροντίδα, επισκευή και συντήρηση της συσκευής, έχουν την απαραίτητη εξειδίκευση και ότι πριν από την έναρξη των εργασιών διάβασαν και κατανόησαν τις απαραίτητες οδηγίες ασφαλείας και τα σχετικά κεφάλαια του εγχειριδίου.

Οι οδηγίες λειτουργίας πρέπει να φυλάσσονται οπωσδήποτε σε ασφαλές μέρος για να μπορούν να χρησιμοποιηθούν αργότερα!

Σε περίπτωση ακατάλληλου χειρισμού, αντικανονικής χρήσης και αυθαίρετων μετατροπών πάνω στη συσκευή, δεν αναλαμβάνεται απολύτως καμία ευθύνη για ατυχήματα, τραυματισμούς και βλάβες! Για λόγους ασφαλείας απαγορεύονται αυστηρώς αυθαίρετες μετατροπές και αλλαγές της αυτόματης ηλεκτρονικής συσκευής.

Σε περίπτωση περαιτέρω ερωτήσεων ή αμφιβολιών απευθυνθείτε στον αντιπρόσωπό σας.

Οι υποδείξεις ασφαλείας πρέπει να τηρούνται οπωσδήποτε! Αφορούν την ασφάλειά σας.

2.3. Βασικές υποδείξεις ασφαλείας

Η συσκευή επιτρέπεται να λειτουργεί μόνο εφόσον έγινε η προδιαγραμμένη και σύμφωνα με το εγχειρίδιο εγκατάσταση.

Η λειτουργική τάση και συχνότητα της συσκευής πρέπει να ανταποκρίνονται στην τάση και συχνότητα δικτύου. Τα ηλεκτρικά στοιχεία αναφέρονται στην πινακίδα τύπου της συσκευής. Η συσκευή πρέπει να συνδέεται μόνο σε σωστά εγκαταστημένο, ασφαλισμένο και γειωμένο ρευματοδότη.

Η εγκατάσταση και λειτουργία επιτρέπεται μόνο μέσα σε κλειστούς και ξηρούς χώρους! Επιτρέπεται μόνο η επαγγελματική χρήση της συσκευής!

Πρέπει να γίμεται αμέσως αντικατάσταση χαλασμένων ή ανύπαρκτων προειδοποιητικών υποδείξεων.



ΠΡΟΣΟΧΗ !!

Εσωτερική έκρηξη λυχνίων και λαμπτήρων αερίου νέου

Εγκατάσταση μόνο πάνω σε σταθερή και ανθεκτική επιφάνεια, εν ανάγκη στερεώνετε τη συσκευή. Κατά το πέσιμο της συσκευής μπορεί να προκληθεί εσωτερική έκρηξη των λυχνίων και των λαμπτήρων αερίου νέου. Τα σπασμένα γυαλιά μπορεί να προκαλέσουν πολύ βαριά τραύματα.



ΠΡΟΣΟΧΗ !!

Κίνδυνος ηλεκτροπληξίας

Πριν ανοίξετε τη συσκευή πρέπει να βγάξετε ΠΑΝΤΟΤΕ το ρευματολήπτη από την πρίζα! Μην πιάνετε ποτέ το ρευματολήπτη με βρεγμένα χέρια. Το πίσω μέρος της συσκευής επιτρέπεται να ανοιχτεί μόνο από ειδικό ηλεκτρολόγο. Πολύ επικίνδυνες υψηλές τάσεις στο εσωτερικό της συσκευής, οι οποίες συνεχίζουν να υπάρχουν και μετά την εξαγωγή του ρευματολόπτη από την πρίζα. Η μη τήρηση μπορεί να επιφέρει το θάνατο ή επικίνδυνους τραυματισμούς.



ΠΡΟΣΟΧΗ !!

Κίνδυνος πυρκαγιάς

Η αντικατάσταση των ασφαλειών επιτρέπεται να γίνεται μόνο με τις προδιαγραμμένες ασφάλειες. Μην καλύπτετε ποτέ τις σχισμές αερισμού της συσκευής. Η θερμοκρασία περιβάλλοντος δεν επιτρέπεται να υπερβαίνει ποτέ τους 40°C. Μην υπερφορτώνετε το κύκλωμα ρεύματος και τους αγωγούς τροφοδότησης.

Σε περίπτωση βλάβης βγάξετε αμέσως το ρευματολήπτη από την πρίζα και επιδιορθώστε τη βλάβη μόνο με ειδικό ηλεκτρολόγο. Τραβάτε μόνο το βύσμα και ποτέ το καλώδιο.

Σε περίπτωση αναζήτησης κάποιας βλάβης της συσκευής, μην εμβυσματώνετε και μην βγάξετε του συνδέσμους στο εσωτερικό της συσκευής, εάν η συσκευή βρίσκεται υπό τάση. Η επισκευή γίνεται μόνο όταν η συσκευή δεν βρίσκεται υπό τάση!

Χρησιμοποιείτε μόνο γνήσια ανταλλακτικά.

Η μη τήρηση των ανωτέρω σημείων μπορεί να οδηγήσει σε κίνδυνο της σωματικής σας ακεραιότητας!

3. Έλεγχος συσκευής

3.1. Έλεγχος μετά την παράδοση

Αμέσως μετά την παράδοση της συσκευής κάνετε έλεγχο για τυχόν ζημιές μεταφοράς. Εμφανείς βλάβες πρέπει να τις σημειώσετε στα έντυπα φορτωτικής του μεταφορέα ή να τις δηλώσετε αμέσως μετά την παραλαβή του εμπορεύματος, για να μπορέσετε έτσι να εξασφαλίσετε τις αξιώσεις σας.

Ανοίξτε τη συσκευή και κάνετε έλεγχο της κανονικής εφαρμογής όλων των δομοστοιχείων και συνδέσεων.

Αφαιρέστε το συνημμένο υλικό συναρμολόγησης από το εσωτερικό της συσκευής ή από το κουτί ταμείου.

Σε περίπτωση που ο διαθέσιμος ρευματολήπτης δεν ανταποκρίνεται στις προδιαγραφές της χώρας σας, συνδέστε το κατάλληλο βύσμα στο καλώδιο.



ΠΡΟΣΟΧΗ !!

Κίνδυνος ηλεκτροπληξίας

Η σύνδεση του ρευματολήπτη γίνεται μόνο από ειδικό ηλεκτρολόγο. Εάν δεν τηρηθεί αυτό, εκθέτετε σε κίνδυνο τον εαυτόν σας και τους άλλους!

Εάν υπάρχουν διαθέσιμα ξεχωριστό τμήμα κεφαλής ή μονάδα καθίσματος, τα βγάζετε από τη συσκευασία. Το μοντάρισμα των εξαρτημάτων αυτών πρέπει να γίνει στον τόπο εγκατάστασης, διαφορετικά υπάρχει κίνδυνος βλάβης κατά τη μεταφορά.

4. Μεταφορά, εγκατάσταση και θέση λειτουργίας

4.1. Επιλογή τόπου εγκατάστασης και μεταφορά

Η εγκατάσταση και λειτουργία επιτρέπεται μόνο μέσα σε κλειστούς και ξηρούς χώρους! Η εγκατάσταση σε υπαίθριους ή υγρούς χώρους απαγορεύεται αυστηρώς. Εάν εισχωρήσει υγρασία μέσα στη συσκευή, μπορεί να προκληθούν ατυχήματα ηλεκτροπληξίας ή βλάβες στο εσωτερικό της συσκευής. Αποφεύγετε την έκθεση της συσκευής σε άμεση ηλιακή ακτινοβολία.

Ελέγχετε τους δρόμους μεταφοράς και τις δυνατότητες εγκατάστασης πριν να κάνετε τη μεταφορά. Ιδιαίτερη προσοχή σε συσκευές με ρόδες μεταφοράς σε κατηφορικά δάπεδα.

Η μεταφορά της συσκευής πρέπει να γίνεται με επαρκή αριθμό ατόμων. Προσοχή σε χαμηλά κρεμασμένα φωτιστικά σώματα.

Τοποθετείτε τη συσκευή σε επίπεδη, σταθερή και ανθεκτική επιφάνεια. Μην καλύπτετε ποτέ τις σχισμές αερισμού της συσκευής. Διατηρείτε επαρκή απόσταση από τον τοίχο (τουλάχισ. 10 εκατ.).

Μην τοποθετείτε τη συσκευή κοντά σε:

- α) διασωστικούς εξοπλισμούς, όπως π.χ.:
 - εξόδους κινδύνου
 - πυροσβεστήρες κ.λπ.
- β) δοχεία με εύφλεκτες ύλες, νερό ή χημικές ουσίες,
- γ) πηγές θερμότητας, όπως π.χ.:
 - σώματα καλοριφέρ
 - ανοίγματα συστημάτων κλιματισμού
 - βιτρίνες με άμεση ηλιακή ακτινοβολία κ.λπ.

Μην εκθέτετε τη συσκευή σε φόρτο, που προκαλεί λειτουργικές διαταραχές ή βλάβες, όπως π.χ. σε:

- ισχυρές δονήσεις
- σκόνες και βρωμιές
- άμεση ηλιακή ακτινοβολία ή θερμότητα
- βροχή ή υγρασία
- ισχυρό μαγνητικό πεδίο ή ραδιοκύματα

Στον τόπο εγκατάστασης πρέπει να υπάρχει διαθέσιμος σωστά τοποθετημένος, γειωμένος και ασφαλισμένος ρευματοδότης.

Μην υπερφορτώνετε το κύκλωμα ρεύματος που είναι συνδεδεμένη η συσκευή.

Η τοποθέτηση του καλωδίου πρέπει να γίνει έτσι, ώστε να μην σκοντάφτει κανένας επάνω του. Η μη τήρηση μπορεί να οδηγήσει σε σοβαρούς τραυματισμούς ή σε βλάβη του καλωδίου.

Μην κάμπτετε ισχυρά το καλώδιο και μην τοποθετείτε επάνω του βαριά αντικείμενα, γιατί μπορεί να προκληθεί ζημιά στη μόνωση με δυνατά επακόλουθα εκτεθειμένη τάση, βραχυκύκλωμα και ενδεχόμενη πρόκληση πυρκαγιάς.

4.2. Εγκατάσταση και συναρμολόγηση της συσκευής

Τοποθετείτε τη συσκευή, κάνετε πλήρη εγκατάσταση και μετά βάζετε το ρευματολήπτη στην πρίζα.



ΠΡΟΣΟΧΗ !! Εσωτερική έκρηξη λυχνίων και λαμπτήρων αερίου νέου
Τηρείτε οπωσδήποτε τις υποδείξεις ασφαλείας στο κεφάλαιο 2.3.

4.2.1. Συσσκευές Video μπαρ παραδίνονται σε πλήρη συναρμολόγηση. Δεν είναι απαραίτητες άλλου είδους συναρμολογήσεις. Εξασφαλίζετε σταθερή θέση εγκατάστασης!

4.2.2. Οδηγίες εγκατάστασης ως ορθή συσκευή Video και καθιστή συσκευή Video
Εάν υπάρχουν διαθέσιμα, στερεώνετε σταθερά τα ξεχωριστά εξαρτήματα στη συσκευή με τις συνημμένες βίδες. Το εξάρτημα κεφαλής πρέπει να το κρατάνε τουλάχιστον δύο βοηθοί κατά την εγκατάσταση. Χρησιμοποιείτε σκάλα ή άλλη σταθερή βάση. Εάν υπάρχουν διαθέσιμοι, εμβυσματώνετε τους συνδέσμους των εξαρτημάτων.

Δημιουργείτε ασφαλείς συνδέσεις σύρματος γης.

Οδηγίες μονταρίσματος βλέπε γνήσιο εγχειρίδιο.

Σε περίπτωση αμφιβολιών απευθυνθείτε οπωσδήποτε στον αντιπρόσωπό σας!

4.2.2.1. Ορθή συσκευή Video, διαθέσιμοι τύποι παράδοσης:

- α) με πλήρη συναρμολόγηση και / ή
- β) με ξεχωριστά συσκευασμένο εξάρτημα κεφαλής (με ή χωρίς φωτισμό) και / ή
- γ) με ξεχωριστά συσκευασμένη μονάδα χειρισμού

4.2.2.2. Καθιστή συσκευή Video, διαθέσιμοι τύποι παράδοσης:

- α-γ) όπως η ορθή συσκευή Video και / ή επιπλέον
- δ) με ξεχωριστά συσκευασμένη μονάδα καθίσματος

4.3. Θέση λειτουργίας

Εάν υπάρχουν διαθέσιμοι, ρυθμίζετε ακριβώς τη συσκευή με τους ρυθμιστικούς κοχλίες. Η συσκευή πρέπει να στέκεται σταθερά πάνω στο δάπεδο. Σε περίπτωση λείων δαπέδων, χρησιμοποιείτε πλαστικά καλύμματα κάτω από τα πόδια της συσκευής.

Ελέγχετε την άσογη εφαρμογή όλων των δομοστοιχείων και συνδέσεων. Ιδιαίτερα ελέγχετε με τη βοήθεια ειδικού ηλεκτρολόγου την άσογη εφαρμογή των συνδέσεων σύρματος γης όλων των εκτεθειμένων μεταλλικών τμημάτων!

Κλείνετε τον γενικό διακόπτη. Βάζετε το ρευματολήπτη στην πρίζα αφού πρώτα έχετε τηρήσει όλες τις ανωτέρω αναφερόμενες οδηγίες.

Ανοίγετε τον γενικό διακόπτη. Εάν διαπιστωθεί ασυνήθιστος θόρυβος, καπνός ή παράξενη μυρωδιά μετά το άνοιγμα του διακόπτη, βγάξετε αμέσως το ρευματοδότη από την πρίζα και ζητάτε τη συμβουλή ειδικού ηλεκτρολόγου. Σε περίπτωση αμφιβολιών απευθυνθείτε οπωσδήποτε στον αντιπρόσωπό σας!



ΠΡΟΣΟΧΗ !! Κίνδυνος πυρκαγιάς
Μην λειτουργείτε σε καμία περίπτωση τη χαλασμένη συσκευή.

4.4. Ρυθμίσεις

Τα προγράμματα και τις ενδεχόμενες ρυθμίσεις του μοντέλου τις βρίσκετε στο συνημμένο γνήσιο εγχειρίδιο λειτουργίας.



ΠΡΟΣΟΧΗ !! Κίνδυνος ηλεκτροπληξίας
Τηρείτε οπωσδήποτε τις υποδείξεις ασφαλείας στο κεφάλαιο 2.

Σε περίπτωση αμφιβολιών απευθυνθείτε οπωσδήποτε στον αντιπρόσωπό σας!

5. Έλεγχος, συντήρηση και φροντίδα

5.1. Γενικές οδηγίες



ΠΡΟΣΟΧΗ!! Κίνδυνος ηλεκτροπληξίας

Τηρείτε οπωσδήποτε τις υποδείξεις ασφαλείας στο κεφάλαιο 2.

Ελέγχετε τακτικά την κατάσταση του καλωδίου. Σε περίπτωση χαλασμένου καλωδίου ή ρευματολήπτη, διακόπτεται αμέσως τη λειτουργία της συσκευής και την επισκευάζετε με ειδικό ηλεκτρολόγο.

Ελέγχετε οπωσδήποτε την ύπαρξη και το ευανάγνωστο των προειδοποιητικών υποδείξεων, και αν είναι απαραίτητο κάνετε αντικατάστασή τους (βλέπε κεφάλαιο 8).

5.2. Συντήρηση

Η συσκευή αυτή καθ' αυτή δεν χρειάζεται συντήρηση.

5.3. Καθάρισμα πλαισίου και εξωτερικής οθόνης

1. Διακόπτετε τη λειτουργία της συσκευής και βγάξετε το ρευματολήπτη από την πρίζα!
2. Καθαρίζετε το πλαίσιο και την εξωτερική οθόνη με μαλακό, υγρό (όχι πολύ βρεγμένο πανί) και ελαφρύ απορρυπαντικό (μην χρησιμοποιείτε διαλυτικά, οξέα ή απορρυπαντικά τριψίματος).

6. Σέρβις

6.1. Γενικές οδηγίες



ΠΡΟΣΟΧΗ !! Κίνδυνος ηλεκτροπληξίας

Τηρείτε οπωσδήποτε τις υποδείξεις ασφαλείας στο κεφάλαιο 2.

Σε περίπτωση χαλασμένου καλωδίου ή ρευματολήπτη, διακόπτεται αμέσως τη λειτουργία της συσκευής και την επισκευάζετε μόνο με ειδικό ηλεκτρολόγο. Υποδείξεις ασφαλείας βλέπε γνήσιο εγχειρίδιο λειτουργίας.

Σε περίπτωση αμφιβολιών απευθυνθείτε οπωσδήποτε στον αντιπρόσωπό σας!

6.2. Αντικατάσταση χαλασμένων σωμάτων φωτισμού

1. Διακόπτετε τη λειτουργία της συσκευής και βγάξετε το ρευματολήπτη από την πρίζα!
2. Προσοχή, το σώμα φωτισμού μπορεί να καίει!
3. Κάνετε αντικατάσταση των σωμάτων φωτισμού μόνο με προδιαγραμμένα ανταλλακτικά. Οδηγίες σέρβις βλέπε γνήσιο εγχειρίδιο λειτουργίας.

7. Θέση εκτός λειτουργίας

7.1. Γενικές οδηγίες



ΠΡΟΣΟΧΗ!! Κίνδυνος ηλεκτροπληξίας

Τηρείτε οπωσδήποτε τις υποδείξεις ασφαλείας στο κεφάλαιο 2.

7.2. Αποσυναρμολόγηση

Βγάξετε το ρευματολήπτη από την πρίζα. Αποσυναρμολογείτε όλα τα περιγραφόμενα στο κεφάλαιο 4.2 εξαρτήματα στη αντίθετη σειρά. Το εξάρτημα κεφαλής πρέπει να το κρατάνε τουλάχιστον δύο βοηθοί κατά την αποσυναρμολόγηση.

7.3. Μετατόπιση

Κάνετε τη μεταφορά και επαναλειτουργήστε τη συσκευή όπως περιγράφεται στο κεφάλαιο 4.

7.4. Απομάκρυνση

Η απομάκρυνση της συσκευής γίνεται μόνο από εξουσιοδοτημένη εταιρία.

8. Προειδοποιητικές υποδείξεις

Οι προειδοποιητικές υποδείξεις, σε κείμενο ή σε εικόνα, ως αυτοκόλλητες ετικέτες ή σφραγίδες, ή στη μορφή αυτών των οδηγιών λειτουργίας, παλιώνουν με το πέρασμα του χρόνου. Ο εκμεταλλευτής της συσκευής είναι υπεύθυνος για την ύπαρξη και το ευανάγνωστο των προειδοποιητικών υποδείξεων.

Πρέπει να γίνεται αμέσως αντικατάσταση χαλασμένων ή ανύπαρκτων προειδοποιητικών υποδείξεων. Σε περίπτωση ανάγκης απευθυνθείτε στον αντιπρόσωπό σας.

Οι οδηγίες λειτουργίας πρέπει να φυλάσσονται οπωσδήποτε σε ασφαλές μέρος για να μπορούν να χρησιμοποιηθούν αργότερα!

CONTENTS

1.	BEFORE USING THIS PRODUCT	1
1.1.	INSPECTIONS IMMEDIATELY AFTER TRANSPORTING THE PRODUCT TO THE LOCATION	2
2.	INTRODUCTION TO THIS SERVICE MANUAL	4
3.	INSTALLATION AND SERVICE INSTRUCTIONS.....	5
3.1.	HANDLING AND INSTALLATION PRECAUTIONS.....	5
3.2.	COIN HANDLING	5
3.3.	NAME OF PARTS	6
3.4.	ACCESSORIES.....	7
3.5.	SHIPPING THE GAME BOARD.....	8
3.6.	SHIPPING THE GD-ROM DRIVE	8
3.7.	ASSEMBLY INSTRUCTIONS	9
3.7.1.	ASSEMBLE THE MACHINE	10
3.7.1.1.	ASSEMBLE THE PTV	10
3.7.1.2.	ATTACH THE GUARD RAILS	11
3.7.1.3.	ATTACH THE GUN CABINET	11
3.7.1.4.	FIT THE PTV.....	12
3.7.2.	LEG-LEVELLING PROCEDURE	13
3.7.3.	COIN HANDLING INSTALLATION.....	15
3.7.3.1.	WIRING CONNECTIONS.....	16
3.7.4.	CONNECTION TO THE POWER SUPPLY	17
3.7.5.	ASSEMBLY CHECK	18
3.8.	MOVING THE MACHINE	20
3.9.	FUSES.....	21
3.10.	REPLACEMENT OF FLUORESCENT LAMP AND OTHER LAMPS	22
3.10.1.	FLUORESCENT LAMP REPLACEMENT.....	22
3.10.2.	LAMP REPLACEMENT.....	23
3.11.	TROUBLESHOOTING.....	24
3.12.	CONTROLLER	25
3.12.1.	REPLACING THE MICRO-SWITCH.....	25
3.12.2.	REPLACING THE SENSOR UNIT.....	25
3.13.	GAMEBOARD.....	27
3.13.1.	REMOVING THE BOARD.....	27
3.13.2.	REMOVING THE GD-ROM DRIVE	29
3.14.	COMPOSITION OF THE GAME BOARD.....	30
3.15.	PERIODIC CHECK AND INSPECTION	31
4.	HOW TO PLAY.....	32
4.1.	INTRODUCTION TO THE GAME	33
4.1.1.	MISSIONS.....	33
4.2.	PLAY INSTUCTIONS	34
4.2.1.	GAME SCREEN.....	35
4.2.2.	RELOADING BULLETS	35
4.2.3.	GAME OVER.....	35
4.2.4.	LOSING LIFE POINTS.....	36
4.2.5.	SPECIAL TASKS	36
4.2.6.	CLEARING THE STAGE	37
4.2.7.	AVAILABLE ITEMS	38
4.2.8.	INTERNET RANKING	40
4.2.9.	TIPS FOR HIGH SCORES	40
5.	MAINTENANCE INSTRUCTIONS.....	41
5.1.	EXPLANATION OF TEST AND DATA DISPLAY	41
5.1.1.	VTS ASSEMBLY	42
5.2.	SYSTEM TEST MODE	43
5.2.1.	RAM TEST	44
5.2.2.	JVS TEST.....	45
5.2.3.	SOUND TEST	46
5.2.4.	CRT TEST.....	46
5.2.5.	SYSTEM ASSIGNMENTS	47
5.2.5.1.	COIN ASSIGNMENTS.....	48
5.2.5.2.	COIN/CREDIT SETTING (COIN CHUTE COMMON TYPE).....	49

5.2.5.3.	MANUAL SETTING.....	50
5.2.6.	BOOKKEEPING.....	51
5.2.7.	BACKUP DATA CLEAR.....	52
5.2.8.	CLOCK SETTING.....	52
5.2.9.	GAME TEST MODE.....	53
5.2.9.1.	INPUT TEST.....	53
5.2.9.2.	OUTPUT TEST.....	53
5.2.10.	GAME ASSIGNMENTS.....	54
5.2.11.	GUN ADJUSTMENT.....	55
5.2.11.1.	BOOKKEEPING.....	56
5.2.11.2.	BACKUP DATA CLEAR.....	57
6.	COIN MECH INSTALLATION AND CREDIT BOARD SET UP.....	58
6.1.	INTRODUCTION.....	58
6.1.1.	PRICE OF PLAY SETTINGS UK.....	60
6.1.2.	PRICE OF PLAY SETTINGS Austria-Czech-Denmark-Norway-Israel-France2.....	61
6.1.3.	PRICE OF PLAY SETTINGS - BELGIUM.....	62
6.1.4.	PRICE OF PLAY SETTINGS - FRANCE.....	63
6.1.5.	PRICE OF PLAY SETTINGS - ITALY.....	64
6.1.6.	PRICE OF PLAY SETTINGS - PORTUGAL.....	65
6.1.7.	PRICE OF PLAY SETTINGS - NETHERLANDS.....	66
6.1.8.	PRICE OF PLAY SETTINGS - SPAIN.....	67
7.	DESIGN RELATED PARTS.....	68
8.	PARTS LIST.....	69
8.1.	SPY-0000UK TOP ASSY SPY DX.....	69
8.2.	SPY-0500UK ASSY PTV.....	70
8.3.	SPY-0520UK ASSY BILLBOARD DX.....	71
8.4.	SPY-0530UK ASSY MASK.....	72
8.5.	SPY-1000UK ASSY PTV CABI DX.....	73
8.6.	SPY-1060UK ASSY LID UPPER.....	75
8.7.	SPY-1070UK ASSY LID LOWER.....	75
8.8.	SPY-1100UK ASSY CONTROLLER CABINET.....	76
8.9.	SPY-1150UK ASSY FENCE L.....	77
8.10.	SPY-1160UK ASSY FENCE R.....	78
8.11.	SPY-2000UK ASSY CTRL PANEL DX.....	79
8.12.	SPY-4000UK ASSY MAIN BD DX.....	80
8.13.	SPY-4100UK ASSY PWR SPLY.....	81
8.14.	SPY-INST-DX ASSY INST KIT SPY DX.....	82
8.15.	HOD-1020UK ASSY AC UNIT.....	82
8.16.	HOD-1070UK ASSY SPEAKER.....	83
8.17.	HOD-1530 ASSY FAN UNIT.....	83
9.	APPENDIX A - ELECTRICAL SCHEMATIC.....	84
9.1.	WIRE COLOURS.....	84
9.2.	ELECTRICAL SCHEMATIC.....	84

1. BEFORE USING THIS PRODUCT

To ensure the safe usage of the product, be sure to read the following before using the product. The following instructions are intended for the use of QUALIFIED SERVICE PERSONNEL ONLY. After carefully reading and sufficiently understanding the instructions should any activity be carried out on the product. Only qualified service personnel should carry out maintenance on the product.

Terms such as **WARNING!**, **CAUTION**, and **IMPORTANT!** Are used where an explanation is given which requires special attention, depending on the potential risk. SEGA is not responsible for injury or damage caused by use in a manner contrary to the instructions stated in this document. In order to prevent accidents warning stickers and printed instructions are applied in the places where a potentially hazardous situation relating to the product could arise. Be sure to comply with these warnings.



WARNING!

Indicates that mishandling the product by disregarding this warning will cause a potentially hazardous situation which can result in death or serious injury.



CAUTION!

Indicates that mishandling the product by disregarding this caution will cause a potentially hazardous situation which can result in personal injury and or material damage.



IMPORTANT!

This is cautionary information which should be complied with when handling the product. Indicates that mishandling the product by disregarding this will cause a potentially hazardous situation which may not result in personal injury but could damage the product.

Be sure to turn off the power and disconnect from the mains supply before working on the machine.

Ensure that the correct fuse(s) is fitted to the machine.

Details of the correct fusing of the machine are enclosed in the Service Manual.

Ensure that only qualified Service Engineers perform any maintenance work on the machine.

Specification changes, removal of equipment, conversion and/or addition, not designated by SEGA are not permitted and will invalidate this product's CE conformity.

The parts of the product also include any warning labels or safety covers for personal protection etc. A potential hazard will be created if the machine is operated while any parts have been removed. Should any doors, lids or protective covers be damaged or lost, do not operate the product. SEGA is not liable in any whatsoever for any injury and/or damage caused by specification changes not designated by SEGA.

Before installing the product, check for the Electrical Specification Sticker, SEGA products have a sticker on which the electrical specifications are detailed. Ensure that the product is compatible with the power supply voltage and frequency requirements of the location in which the machine is to be installed.

Install and operate the machine only in places where appropriate lighting is available, allowing warning stickers to be clearly read.

To ensure maximum safety for both customers and operators, stickers and printed instructions describing potentially hazardous situations are applied to places where accidents could occur. Ensure that where the product is operated has sufficient lighting to allow any warnings to be read. If any sticker or printed warning is removed or defaced, do not operate the machine, until it has been replaced by an identical item.

When handling the monitor, be very careful. (Applies only to product with monitor)

Some of the monitor (TV) parts are subject to high tension voltage. Even after turning off the power some components are still occasionally subject to high tension voltage. Monitor repair and replacement should be performed by qualified service engineers only.

In cases where commercially available monitors and printers are used only the contents relating to this product are stated in this manual. Some commercially available equipment has functions and reactions not stated in this manual. Read this manual in conjunction with the specific manual of such equipment.

Descriptions contained herein may be subject to change without prior notification.

The contents described herein are fully prepared with due care. However, should any question arise or errors be found please contact SEGA.

1.1. INSPECTIONS IMMEDIATELY AFTER TRANSPORTING THE PRODUCT TO THE LOCATION



IMPORTANT!

- Inspection should only be carried out by QUALIFIED SERVICE PERSONNEL.

Normally, at the time of shipment, SEGA products are in a state to allowing usage immediately after transporting to the location. Nevertheless, an irregular situation may arise during transportation preventing this. Before turning on the power, check the following points to ensure that the product has been transported safely.

- Are there any dented parts or defects (cuts, etc.) on the external surfaces of the product?
- Are castors and leg adjusters present and undamaged?
- Do the power supply voltage and frequency requirements meet with the local supply?
- Are all wiring connectors correctly and securely connected? Unless connected in the correct direction, connector connections cannot be made successfully. Do not insert connectors forcibly.
- Are all IC's of each IC BD firmly inserted?
- Does the power cord have any cuts or dents?
- Do fuses meet the specified rating?
- Are such units such as monitors, control equipment, IC BD, etc. firmly secured?
- Are all earth wires connected?
- Are all accessories available?
- Can all doors and lids be opened with the accessory keys and/or tools?

CONCERNING THE STICKER DISPLAY

SEGA product has stickers describing the product manufacture number (Serial Number) and electrical specification. If you require service assistance you will require the Serial Number. Identical machines may have different parts fitted internally. Only by quoting the Serial Number will the correct parts be identified.

CONCERNING WARNING STICKERS

SEGA product has warning displays on stickers, labels or printed instructions adhered/attached to or incorporated in the places where hazardous situations can arise. The warning displays are intended for the accident prevention of customers and service personnel.

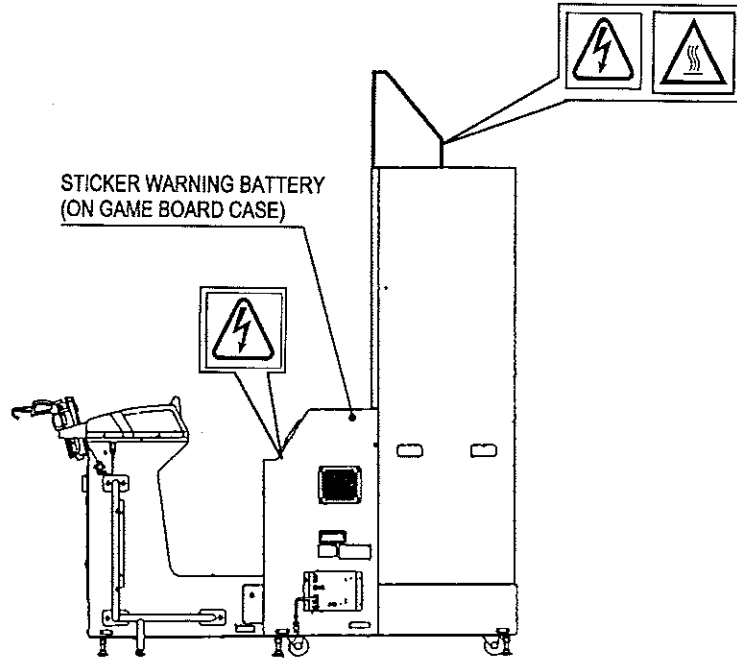
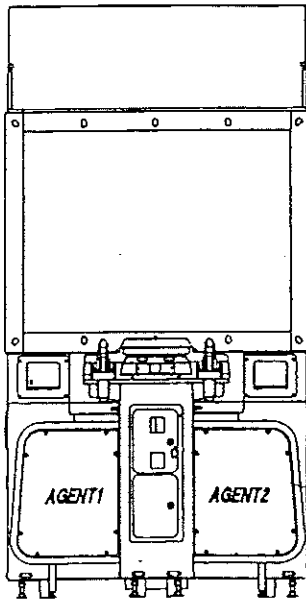

SPECIFICATIONS

Installation Space (cm):	114X164.6	
Height (cm):	225.4	
Weight (kg):	242	
Power, Max:	Rated Voltage (V.AC):	230
	Rated Current (A):	2.1A
Operating Temperature Range	5-30°C	

Note: Descriptions in this manual are subject to change without prior notice.

2. INTRODUCTION TO THIS SERVICE MANUAL

SEGA ENTERPRISES LTD., supported by its experience in electronic high technology of VLSIs, microprocessors etc. and with a wealth of experience, have for more than 30 years been supplying various innovative and popular games to the world market. This Service Manual is intended to provide detailed descriptions together with all the necessary information covering the general operation of electronic assemblies, electromechanicals, servicing controls, spare parts, etc. as regards **CONFIDENTIAL MISSION DELUXE**, a new SEGA product. This manual is intended for those who have knowledge of electricity and technical expertise especially in IC's, CRT's, microprocessors etc. Carefully read this manual to acquire sufficient knowledge before working on the machine. Should there be any malfunction, non-technical personnel should under no circumstances touch the interior systems. Should such a situation arise contact the nearest branch listed below or our head office.

SEGA AMUSEMENTS EUROPE LTD./ SEGA SERVICE CENTRE

Unit 2 Industrial Estate,
Leigh Close,
New Malden,
Surrey,
KT3 3NL,
England.

Telephone: +44(0) 20 8336 2256

Fax: +44(0) 20 8336 1715

3. INSTALLATION AND SERVICE INSTRUCTIONS



IMPORTANT!

- Installation and commissioning should only be carried out by **QUALIFIED SERVICE PERSONNEL**.

3.1. HANDLING AND INSTALLATION PRECAUTIONS

When installing or inspecting the machine, be very careful of the following points and pay attention to ensure that the player can enjoy the game safely.

The game must NOT be installed under the following conditions:

- Outside, the game is designed for indoor use only.
- In areas directly exposed to sunlight, high humidity, dust, excessive heat or extreme cold.
- In locations that would present an obstacle in the case of an emergency i.e. near fire equipment or emergency exits.
- On unstable surfaces or surfaces subject to vibration.
- Where liquids, other than routine cleaning, may come into contact with the game.

Important:

- This machine should only be installed by Qualified Service Personnel.
- Be sure to switch the supply power OFF and remove the mains supply plug from the machine before any work is carried out on the machine.
- Do not attempt to repair the PCB's (Printed Circuit Boards) yourself. This will void the warranty. The PCB's contain static sensitive devices that could be damaged.
- Always return a faulty part to your distributor with adequate packaging and protection.
- When removing the plug from the mains always grasp the plug not the cable.
- Do not use a fuse that does not meet the specified rating.
- Make sure all connections are secure before applying power.



IMPORTANT!

- Ensure that the mains lead is not damaged. If the mains lead is damaged in any way there could be a danger of electric shock or a fire hazard.
- Ensure that the power supply is fitted with circuit protection. Using the power supply without circuit protection is a fire hazard.

3.2. COIN HANDLING

Standard Sega machines are fitted with a C120 coin mechanism, however, as a service to our customers Sega machines can be supplied with no coin mechanism or door allowing the customer to fit a coin handling option from the approved list. Fit only the coin handling arrangements detailed below and follow the instructions provided in section 3.7. Failure to fit the coin handling options detailed or failure to follow the installation instructions will render the machine, under the CE marking directive, void.

Approved coin handling options:

- Coin controls C120/C220
- Generic mechanical
- Mars (MS111B1 and ME115)
- SECI RM4-G20

3.3. NAME OF PARTS

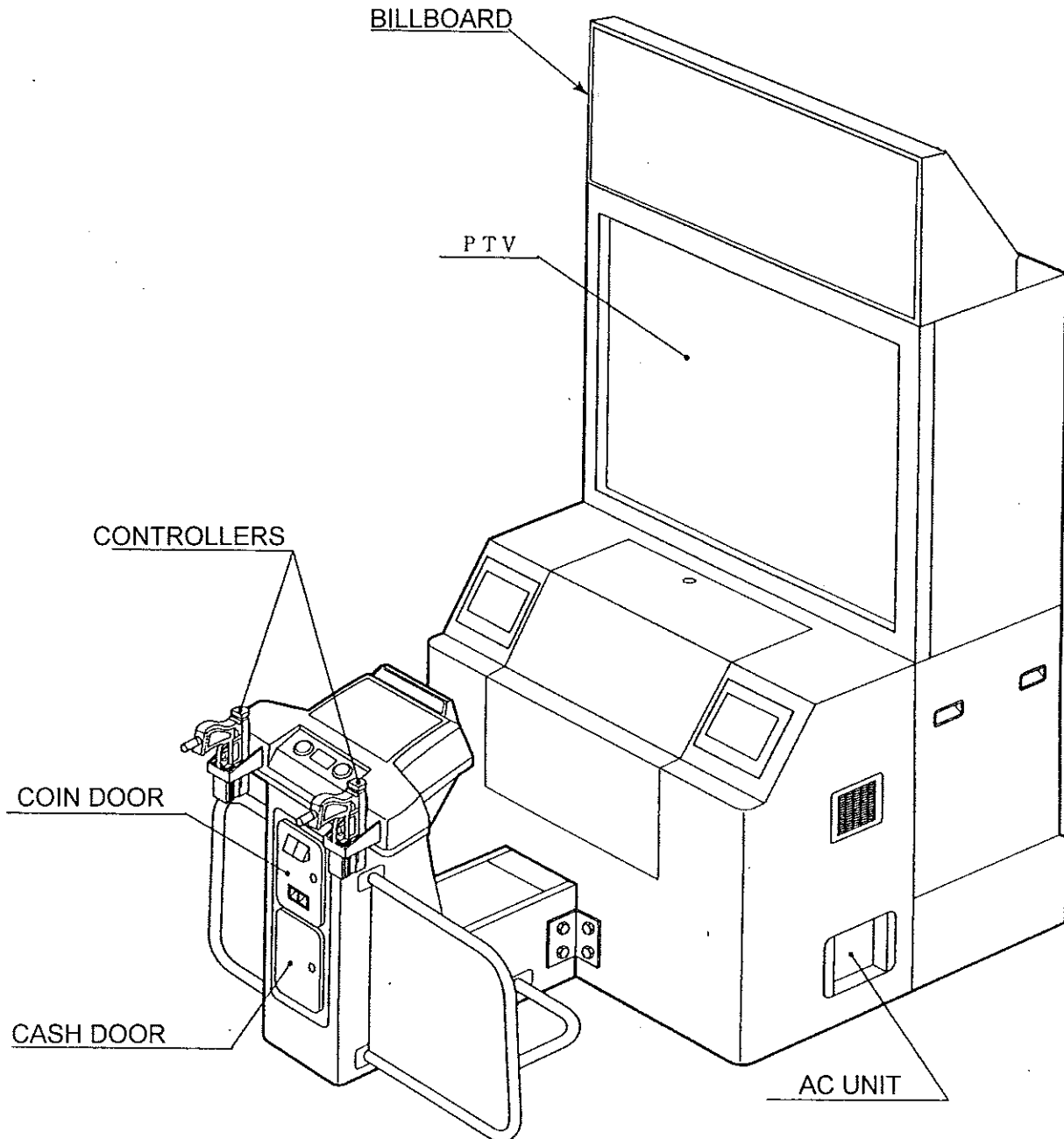

	Width (cm)	Length (cm)	Height (cm)	Weight (kg)
PTV	114	53	158	91
BILLBOARD	114	40	40	19
MAIN CABI DX	114	96.8	93.9	87
GUN CABI	54.8	101	98.7	40
When Assembled	114	164.6	224.8	247

3.4. ACCESSORIES

The machine is supplied with an installation kit. Please ensure the following parts are supplied:

Ind #	Part No.	Description	Component Reference	Qty
1	SPY-0520UK	ASSY BILLBOARD DX		1
2	HOD-0006	L BRKT		2
22	PK0268	CARTON BOX INST KIT SPY		1
23	SAECE-067	DECLARATION OF CONFORMITY		1
24	SPY-2002UK	INST PLATE SPY DX MULTI		1
101	PK0018	BUBBLE WRAP SMALL X 1M R		0.03
201	030-000850-SB	M8X50 BLT W/S BLK	FENCE L+R-2EA	4
202	030-000830-SB	M8X30 BLT W/S BLK	FENCE L+R-4EA	8
205	000-T00420-0B	M4X20 MSCR TH BLK	FENCE L+R-2EA	4
206	068-441616-0B	M4 WSHR 16OD FLT BLK	FENCE L+R-2EA	4
207	030-000840-SB	M8X40 BLT W/S BLK	(2)-8	8
208	068-852216-0B	M8 WSHR 22OD FLT BLK	(2)-8, FENCE L+R-6EA	24
209	030-000860-0B	M8X60 BLT BLK	F.CABI-4	4
401	420-6620-01UK	SERVICE MANUAL GD ROM SYS		1
402	OS1019	SELF SEAL BAG 9X12.3/4		2
403	420-6601-01UK	SERVICE MANUAL SPY DX		1
405	390-5160	LAMP WG B TYPE 6V 3W (C2		1
406	509-5080	SW MICRO TYPE (SS-5GL2)		1
413	514-5078-5000	FUSE 5X20 CERAMIC SB 500		1

3.5. SHIPPING THE GAME BOARD

STOP
IMPORTANT!

- When returning the GAME BOARD for repair or replacement, be sure to package the entire ASSY SHIELD CASE in the original card transit box - THERE ARE NO USER-SERVICEABLE PARTS INSIDE.
- Failure to return the GAME BOARD in this manner may invalidate the warranty.

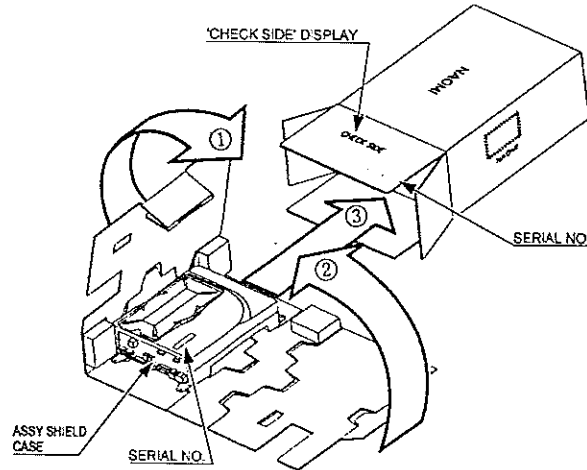

Pack the ASSY SHIELD CASE **ALONG WITH DIMM BOARD** in the original transit box as shown. Putting it upside down or packing otherwise in the manner not shown can damage the GAME BOARD and other parts.

3.6. SHIPPING THE GD-ROM DRIVE

STOP
IMPORTANT!

- When returning the GD-ROM DRIVE for repair or replacement, be sure to package it in the original card transit box - THERE ARE NO USER-SERVICEABLE PARTS INSIDE.
- Ensure the GD-ROM Disk is removed and the GD-ROM Drive Lid is replaced on the unit, with fixing screw, before packaging. Also, remove the GD-ROM Drive Bracket and store with the four screws for reuse.
- Failure to return the GD-ROM DRIVE in this manner may invalidate the warranty.

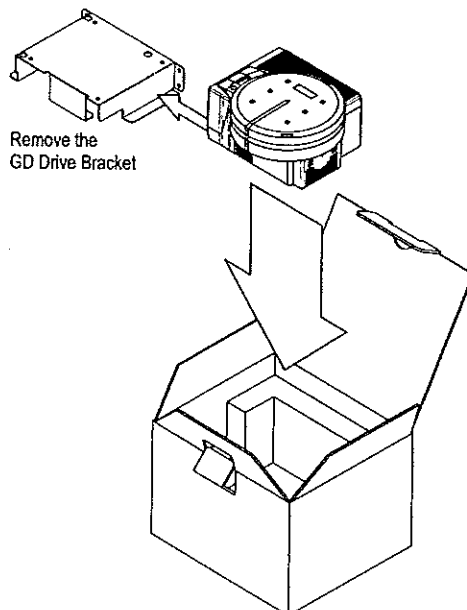

3.7. ASSEMBLY INSTRUCTIONS



WARNING!



IMPORTANT!

- Perform the assembly by following the procedure herein stated. Failure to comply with the instructions, for example, inserting the plug into an outlet at a stage not mentioned in this manual can cause an electric shock
- Assembling should be performed as per this manual. Since this is a complex machine, erroneous assembling can cause damage to the machine, or malfunction to occur.
- Do not attempt to complete this work alone, a minimum of 2 people are required.
- Assembly should only be carried out by **QUALIFIED SERVICE PERSONNEL**.

When carrying out the assembly work, follow the procedure in the following sequence:

STEP 1: ASSEMBLE THE MACHINE

STEP 2: LEG-LEVELLING PROCEDURE

STEP 3: COIN HANDLING INSTALLATION.

STEP 4: CONNECTION TO THE POWER SUPPLY

STEP 5: ASSEMBLY CHECK

Note that the parts contained within the installation kit are required for the assembly work.



CAUTION!

- Fit all fixings loosely first as detailed in step 1, then position all components before finally tightening fixings at step 4.

3.7.1. ASSEMBLE THE MACHINE

3.7.1.1. ASSEMBLE THE PTV

1. Place the PTV and PTV Cabinet in roughly their final position, in close enough proximity to make the connections shown.

It is imperative that the earth eyes are connected to the plate at the bottom of the PTV.

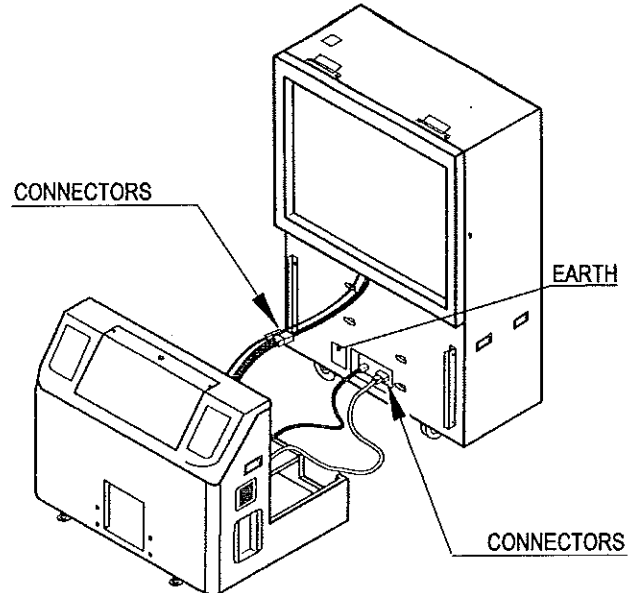

2. Lift the PTV forwards onto the PTV Cabinet, using a minimum of four workers to lift the PTV, plus a further worker to steady the PTV Cabinet. Use care during this exercise, as the PTV weighs in excess of 100kg.
3. Ensure the PTV is correctly seated on the PTV Cabinet.

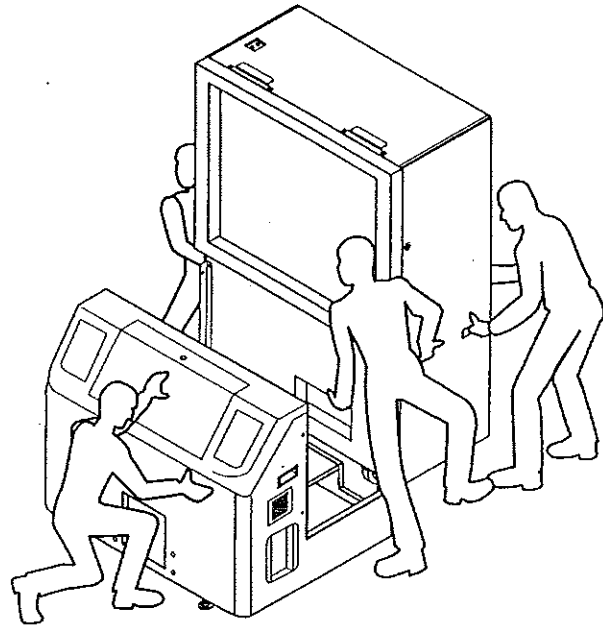

3.7.1.2.ATTACH THE GUARD RAILS

1. Remove the guard rails from their packaging.
2. Fit the rails to the gun cabinet as shown using the M8 bolts and the M4 screws provided.

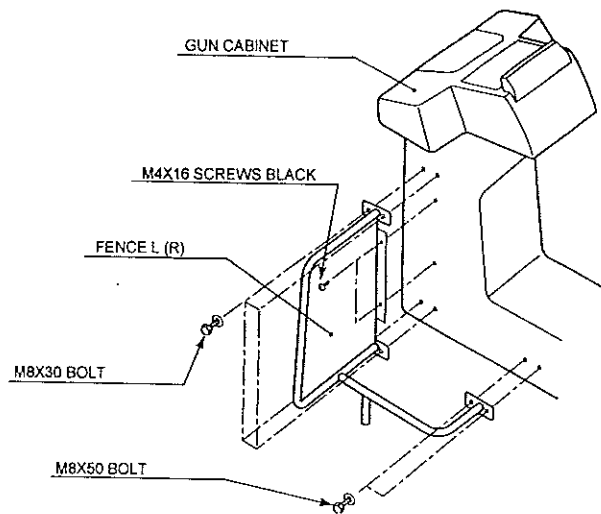

3.7.1.3.ATTACH THE GUN CABINET

1. After fitting the guard rails to the gun cabinet fit the gun cabinet to the main cabinet.
2. Slide the gun cabinet into the hole in the main cabinet as shown.
3. Fix the gun cabinet in position using the joint brackets and M8 bolts provided.

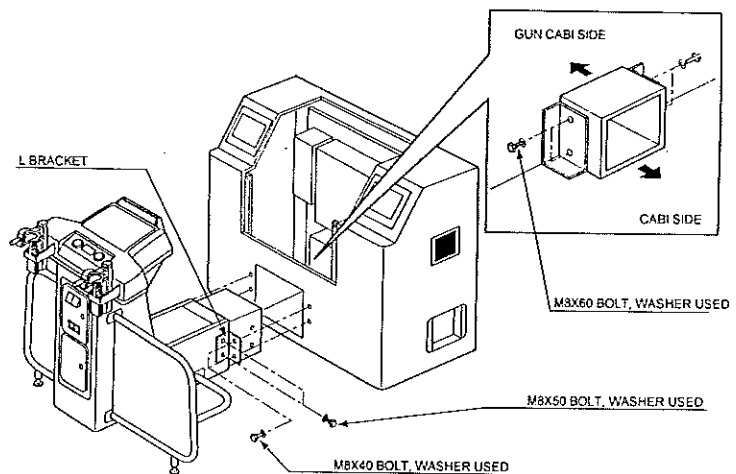

- Once the cabinet is secure connect the connectors as shown.
- Fit the cover in place using the M4x30 screws provided.

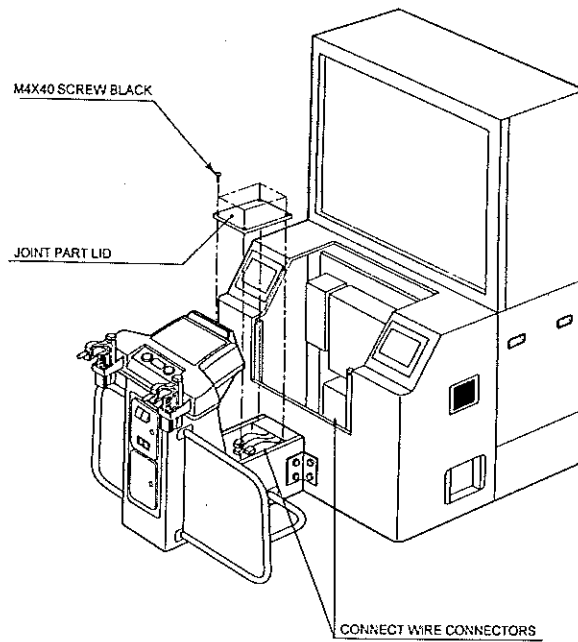

3.7.1.4.FIT THE PTV

- Fix the billboard to the PTV as shown.
- Be sure to fit the connector from the billboard to the PTV. **It is imperative that the earth eye is connected to the top plate of the PTV.**
- Place the billboard onto the PTV and slide it forward under the catches
- Fix the billboard in position using the 2 off M5x16 screws provided

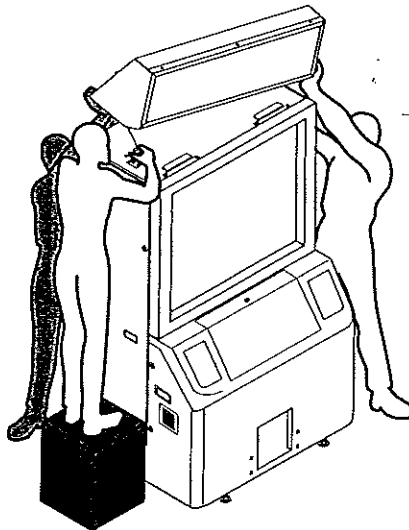
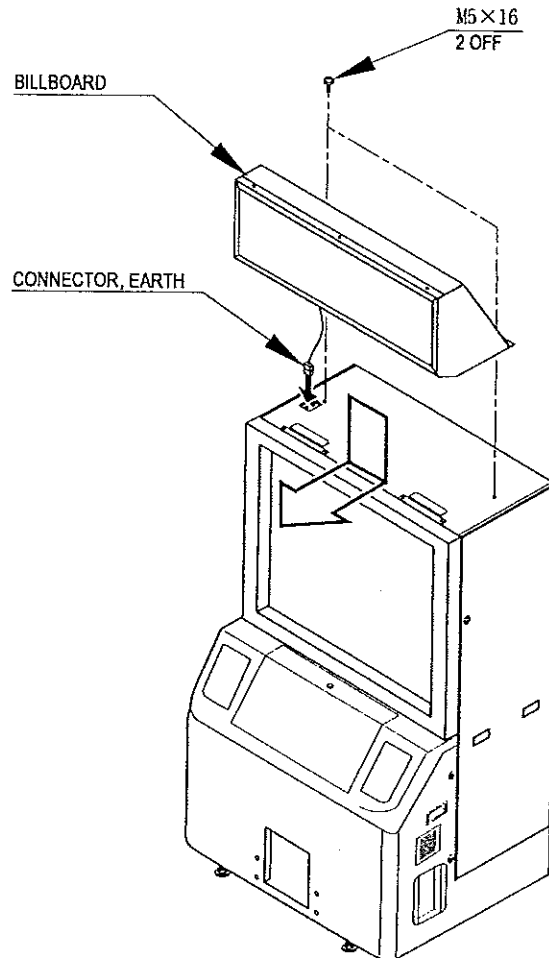

When fitting the Billboard, be sure to use three people for safety.

3.7.2. LEG-LEVELLING PROCEDURE



CAUTION!



IMPORTANT!

- Make sure all of the leg adjusters are in contact with the floor. If they are not the machine may move and cause injury. This operation requires 2 people.

- This operation should only be carried out by QUALIFIED SERVICE PERSONNEL.

This machine has 4 castors and 8 leg adjusters. When the installation position is decided, unscrew the leg adjusters so that they raise each castor a minimum of 5mm from the floor. Make sure the machine is level.

1. Move the machine to its final position.
2. Adjust the leg adjusters as shown until the castors are approximately 5mm off the floor and the machine is level.

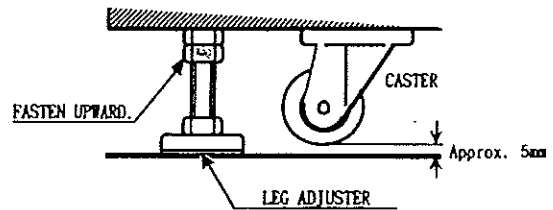
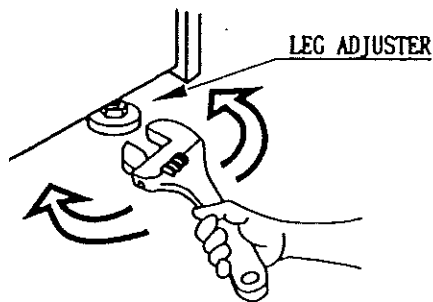
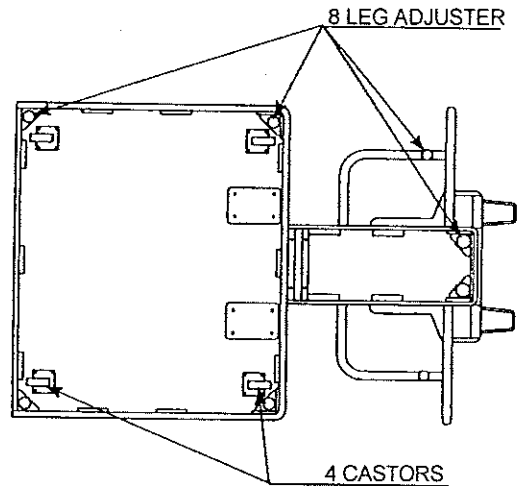

Ensure adequate ventilation is maintained as detailed below



图 2

3.7.3. COIN HANDLING INSTALLATION.

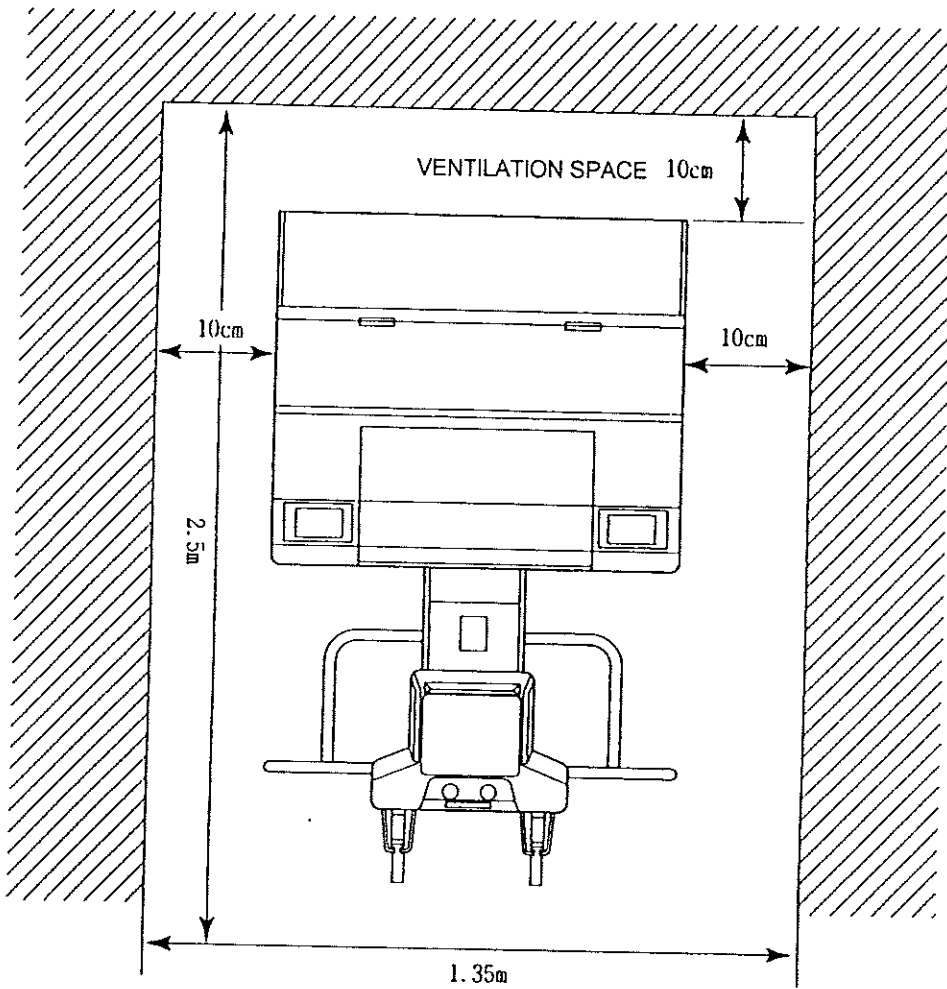

IMPORTANT!

- This operation should only be carried out by **QUALIFIED SERVICE PERSONNEL**.

When fitting the coin mechanism to the door please refer to the specific manufacturers installation instructions for that coin mechanism. To fit the door to the machine, follow the procedure below.

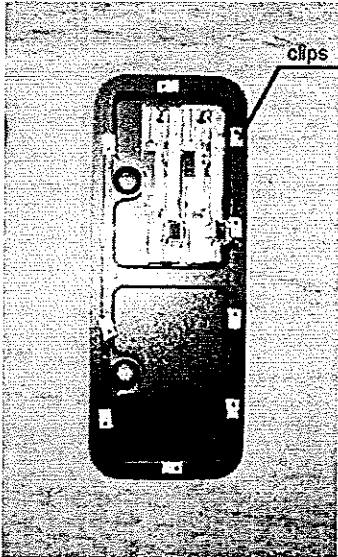

- Loosen all of the bolts on the frame which secure the clips.
- Turn all clips in towards the door.

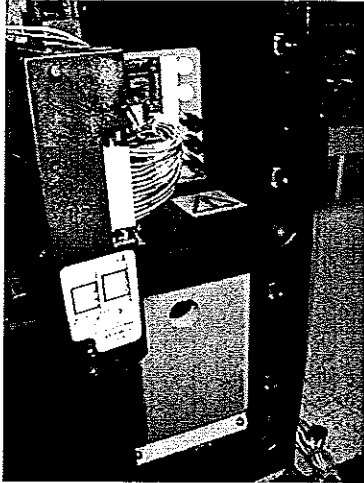

- Position the door into the aperture in the machine.
- Turn the clips around so that they will hold the door in the machine.
- Tighten all of the bolts.

3.7.3.1.WIRING CONNECTIONS.

	LOOM	INSTALLATION
COIN MECH C220B	LM1006IDC LM1006LAMP-0.1	<ul style="list-style-type: none"> • Attach the lamp holder to the bracket on the coin return button. • Attach one 15-way connector to the C220 coin mech. • Attach the other 15-way connector to Validator A on the credit board. • Attach the 2-way connector to 'LAMP' on the VTS board. • Fit the two lamp holders behind the coin return buttons. • Attach the blue cable and orange cable to one mech's micro-switch switch. • Attach the blue/green cable and orange/green cable to the other mech's micro-switch. • Attach the 2-way mate and lok plug to the 2-way mate and lok cap provided. • Attach one 15-way connector to Validator A and the other to Validator B on the credit board
GENERIC MECHANICALS	LM1008 LM1008-LAMP	<ul style="list-style-type: none"> • Fit the lamp holder to the bracket behind the coin return button. • Fit one of the 13-way connectors to the coin mech. • Fit the other 13-way connector to Validator A on the credit board. Note the 13-way connector is keyed and this key must coincide with the key on the credit board.
MARS MS111B1 MARS ME115	LM1007 LM1008-LAMP	<ul style="list-style-type: none"> • Attach the lamp holder to the bracket on the coin return button. • Attach the 2- connector to 'LAMP' on the VTS board. • Attach the validator's own loom to position A on the credit board
SECI, C120	OWN LOOM AND LM1006LAMP-0.1	<ul style="list-style-type: none"> • Attach the lamp holder to the bracket on the coin return button. • Attach the 2- connector to 'LAMP' on the VTS board. • Attach the validator's own loom to position A on the credit board

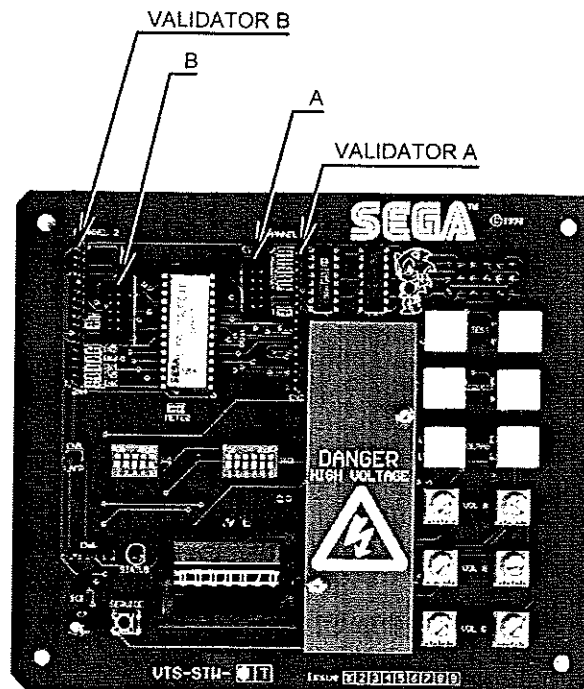

VTS credit board assembly

3.7.4. CONNECTION TO THE POWER SUPPLY



IMPORTANT!

- This operation may only be carried out once the machine has been completely assembled.
- This operation should only be carried out by **QUALIFIED SERVICE PERSONNEL**.

Once the machine has been fully assembled and fixed in position it is ready to be connected to the power supply

1. The socket outlet shall be installed near the equipment and shall be easily accessible.
2. Insert the IEC plug into the IEC socket on the cabinet.
3. Insert the mains cord into the wall outlet
4. Switch on the power at the wall outlet.
5. Switch on the mains switch on the AC unit of the machine.

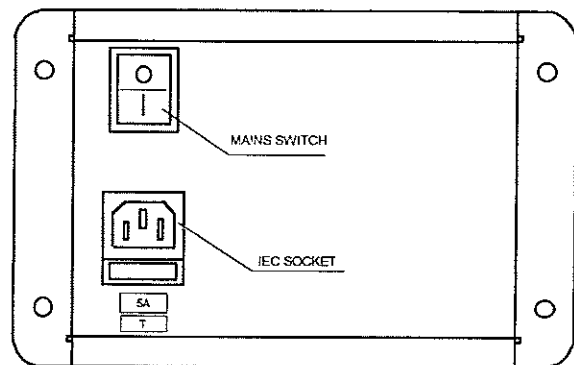

3.7.5. ASSEMBLY CHECK



IMPORTANT!

- This operation should only be carried out by **QUALIFIED SERVICE PERSONNEL**.

When the machine has been installed and power is applied, carry out the following checks in the TEST MODE to ensure that the machine has been assembled correctly and that there are no faults.

```
RAM TEST

IC29 GOOD
IC35 GOOD
IC09 GOOD  IC10 GOOD
IC11 GOOD  IC12 GOOD
IC16 GOOD  IC18 GOOD
IC20 GOOD  IC22 GOOD
IC17 GOOD  IC19 GOOD
IC21 GOOD  IC23 GOOD

PRESS TEST BUTTON TO EXIT
```

Selecting the MEMORY TEST on the test mode screen causes the on board memory to be tested automatically. The game board is satisfactory if the display beside each IC No. shows GOOD

```
DIMM BOARD TEST

PROGRAM VER : 1.02
DIMM SLOT 0 : GOOD
DIMM SLOT 1 : GOOD
DIMM STATUS : GOOD

CHECKING DIMM BD
DIMM0 - GOOD
DIMM1 - GOOD
IC34,35S - GOOD
IC10,11S - GOOD
GD DRIVE - GOOD
--- COMPLETE ---

PRESS TEST BUTTON TO EXIT
```

The DIMM BOARD TEST checks the functionality of the DIMM Board. The DIMM Board is satisfactory when GOOD is displayed as shown.

```
C.R.T. TEST PAGE 1/2

  RED
  GREEN
  BLUE
  WHITE

0           15           31

PRESS TEST BUTTON TO CONTINUE
```

In the TEST mode menu select CRT TEST to check the image quality.

If necessary, adjust the image by referring to the PTV manual supplied.

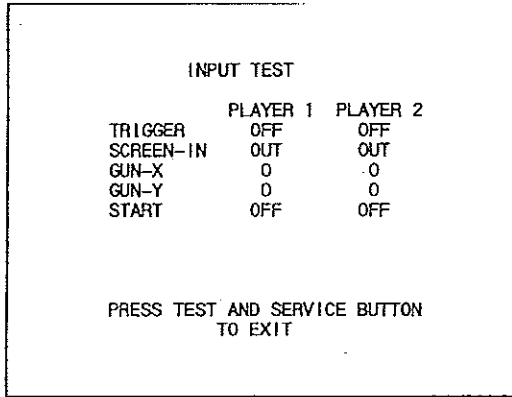
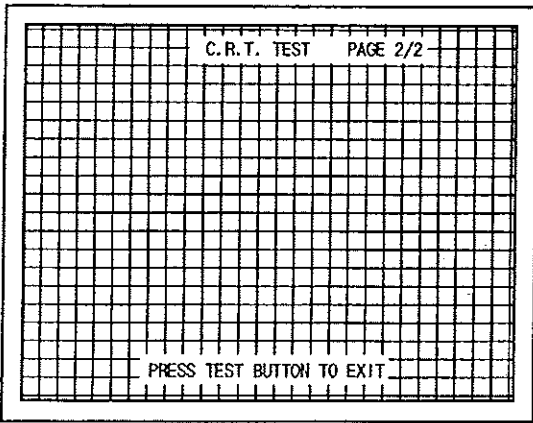

Check the switch functions and connections by selecting INPUT TEST and actuating each switch, checking that 'ON' is displayed to indicate satisfactory operation.



Selecting PLAYER 1 or 2 should cause the relevant lamp to light if connections, etc., are satisfactory.

The GUN ADJUSTMENT parameters should now be set. Refer to section 5.2.11 for detailed instructions.

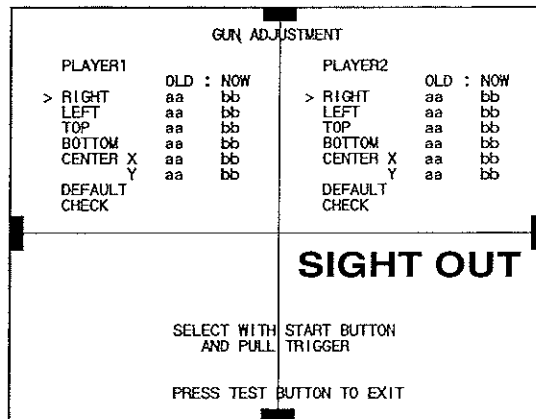

Perform the above inspections also at the time of monthly inspection.

3.8. MOVING THE MACHINE



CAUTION!

- When moving the machine, be sure to remove the plug from the power supply. Moving the machine with the plug inserted can cause the power cord to be damaged, resulting in a fire or electric shock.
- When moving the machine, retract the leg adjusters fully and ensure the casters make contact with the floor. During movement pay careful attention so that the casters or leg adjusters do not damage any other cabling laid on the floor. Such damage could result in a fire or electric shock.



IMPORTANT!

- This operation should only be carried out by **QUALIFIED SERVICE PERSONNEL**.

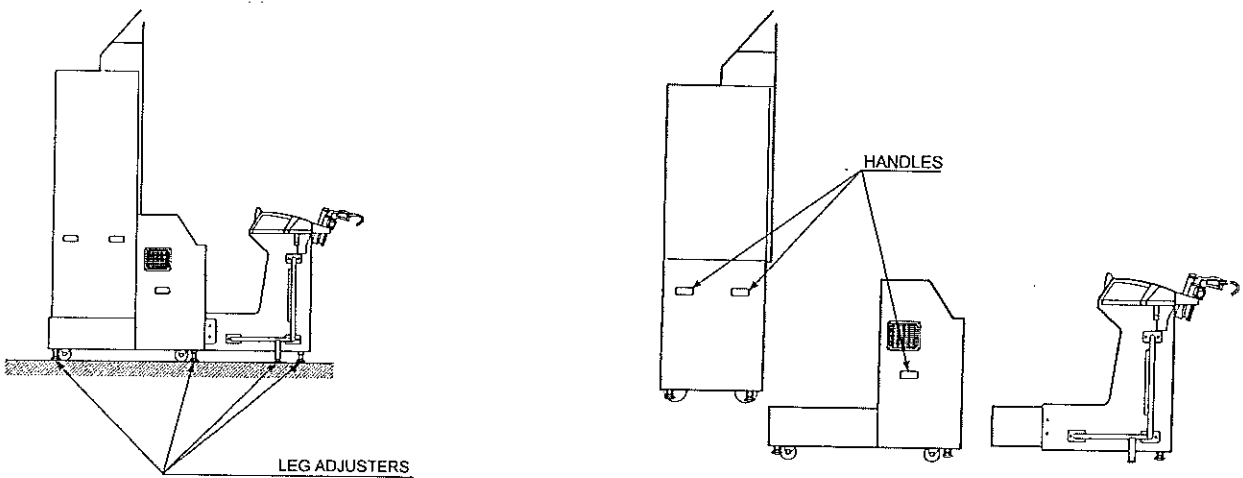

- Do not handle the machine by its plastic parts as this may result in damage or injury.

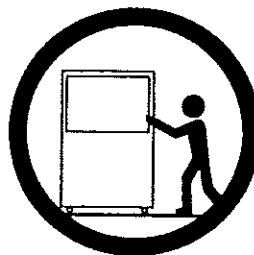
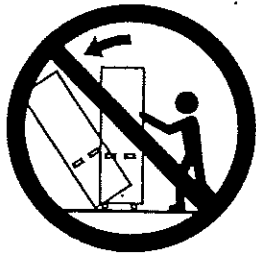

3.9. FUSES



WARNING!



IMPORTANT!

- Never touch places other than those specified. Touching places other than those specified can cause electric shock and short circuit. Disconnect the machine from the supply before attempting the replacement of any fuse.

- FUSES should only be replaced by QUALIFIED SERVICE PERSONNEL.
- Only replace fuses with ones of the same value and type.

There are a number of fuses used on this machine to protect the user and the machine from damage. Only replace the fuse once you have removed the cause of its failure. Detailed below is a list of the fuses used, their location and if relevant PCB reference:

PART NUMBER	LOCATION	TYPE & DETAILS	QTY PER COCKPIT
514-5078-6300	838-11856CE-02 (F1)	5x20 HRC SB 6300mA	1
514-5078-4000	400-5397-01 (F1)	5x20 HRC SB 4000mA	1
514-5078-6300	838-13616 (F1)	5x20 HRC SB 6300mA	1
514-5078-5000	IEC INLET (EP1302)	5x20 HRC SB 5000mA	1

There are also fuses located on the Monitor PCB. Refer to the relevant Monitor manual supplied to reference these fuses.

3.10. REPLACEMENT OF FLUORESCENT LAMP AND OTHER LAMPS



WARNING!



IMPORTANT!

- Never touch places other than those specified. Touching places other than those specified can cause electric shock and short circuit. Disconnect the machine from the supply before attempting the replacement of any lamp.
- Use a step to perform work on the Billboard. Ensure the step is secure to avoid injury.
- The Fluorescent Lamp can get hot and cause burns. Allow the Lamp to cool before touching it.
- Lamps should only be replaced by QUALIFIED SERVICE PERSONNEL.

3.10.1. FLUORESCENT LAMP REPLACEMENT

1. Remove the M4 Truss Screws to remove the Sash. Withdraw the Billboard Plate upwards.
2. To remove the Fluorescent Lamp, first remove both end connectors. Then withdraw the Lamp from the two clips, using care to avoid breakage.
3. Replacement of Lamp is in reverse order of removal.

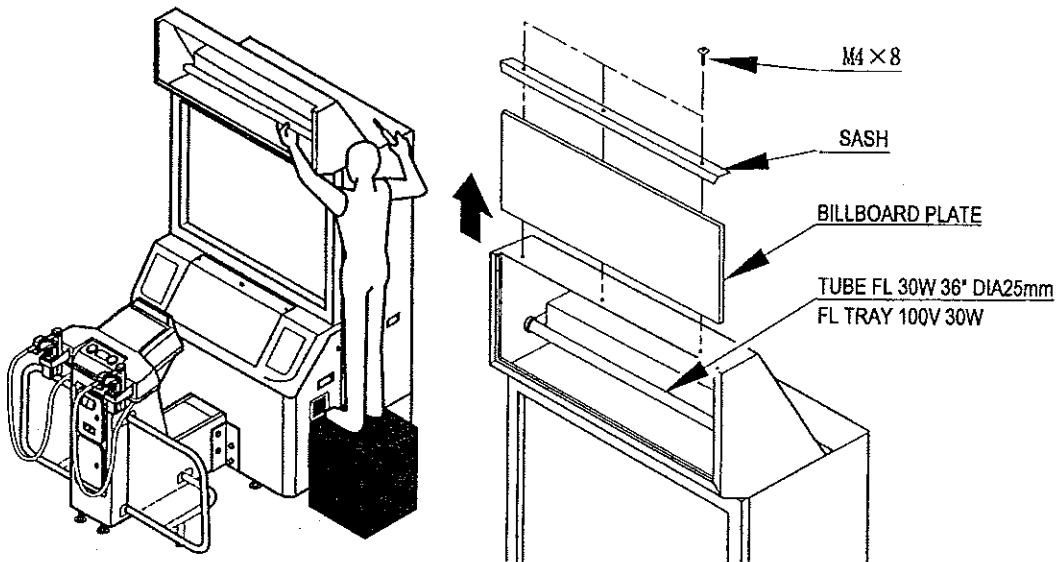

3.10.2.LAMP REPLACEMENT

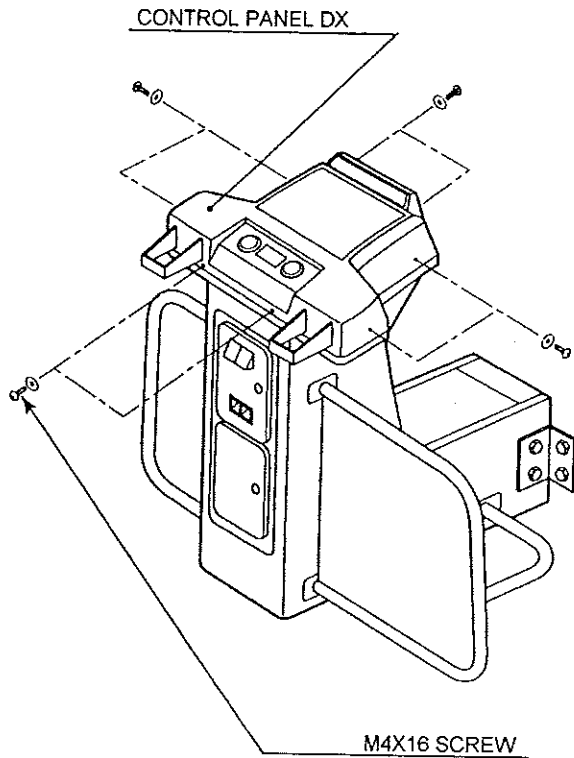

1. Remove the control panel cover as shown by removing the 8 screws holding it in position.
2. Carefully lift the control panel cover up until it is possible to disconnect the wire harness plugs attaching the start switches to the cabinet.
3. Turn the control panel cover over and remove the micro switch from the start switch as shown below.
4. Remove and replace the wedge lamp.
5. Reassemble the control panel cover to the gun cabinet.

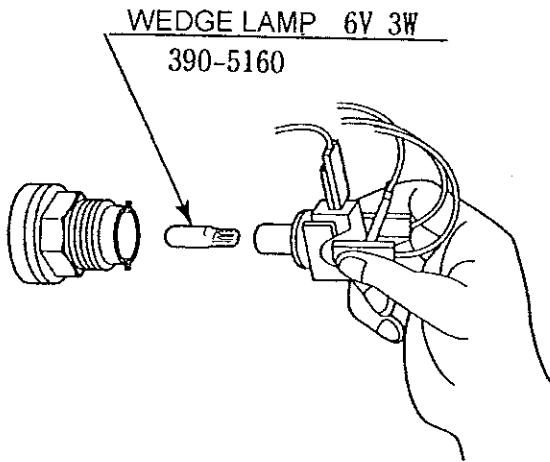

3.11. TROUBLESHOOTING



IMPORTANT!

- These procedures should only be carried out by QUALIFIED SERVICE PERSONNEL.

If a problem occurs, first check the wiring connections.

PROBLEMS	CAUSE	COUNTERMEASURES
When the main switch is turned ON, the machine is not activated	The power is not ON.	Firmly insert the plug into the outlet.
	Incorrect power source/voltage.	Make sure that the power supply/voltage are correct.
	AC Unit CIRCUIT PROTECTION DEVICE (i.e. fuse) was activated due to an instantaneous overcurrent.	First, remove the cause of overcurrent and reinstate the circuit protection device to its original status. Then identify the cause of the fault on the item which caused the overcurrent & fix.
The colour image on the screen is incorrect	Incorrect monitor adjustment.	Make appropriate adjustments. SEE SECTION 3.7.5.
The on-screen image of the monitor sways and/or shrinks	The power source and voltage are not correct.	Make sure that the power supply and voltage are correct.
Sound is not emitted	Sound volume adjustment is not correct.	Adjust the volume setting on the VTS bracket. SEE SECTION 5.1.1
	Malfunctioning BD and Amp.	Perform Sound Test to check it. SEE SECTION 5.2.3.
	Connector connection is incorrect	Check connector connection from Base to Speaker
Controller operation is not satisfactory	Sighting is inaccurate due to environmental conditions, etc.	Adjust the gun sighting alignment. SEE SECTION 5.2.11
	Micro-switch malfunctioning	Replace the micro-switch. SEE SECTION 3.12.1
	Sensor BD is malfunctioning	Replace the Sensor BD. SEE SECTION 3.12.2
The fluorescent lamp does not light up	Fluorescent lamp needs replacement	Replace the fluorescent lamp. SEE SECTION 3.10.1
	The connector is disconnected	Check connector connections in the billboard case.

3.12. CONTROLLER



IMPORTANT!

- These procedures should only be carried out by QUALIFIED SERVICE PERSONNEL.

In cases where the controller's operation is not satisfactory or the controller sight deviates from the direction in which it is pointed, the controller's interior parts may have been damaged. Replace the parts by disassembling the controller by the following procedure. Also, be sure to perform the sighting check in the test mode when the controller parts are replaced. Refer to the diagram on the following page when working on the controllers.

3.12.1. REPLACING THE MICRO-SWITCH.

1. Disassemble the controller.
2. Pullout the micro-switch from COVER RIGHT
3. Take out the micro-switch by de-soldering it.
4. Bend the new micro-switch actuator as shown.
5. Solder the new micro-switch and assemble the controller.
6. By operating the trigger, check if the micro-switch can be turned ON/OFF correctly.

3.12.2. REPLACING THE SENSOR UNIT

1. Disassemble the controller unit.
2. Remove the sensor unit from the cover.
3. Replace with the new sensor unit.
4. Reassemble the controller unit.

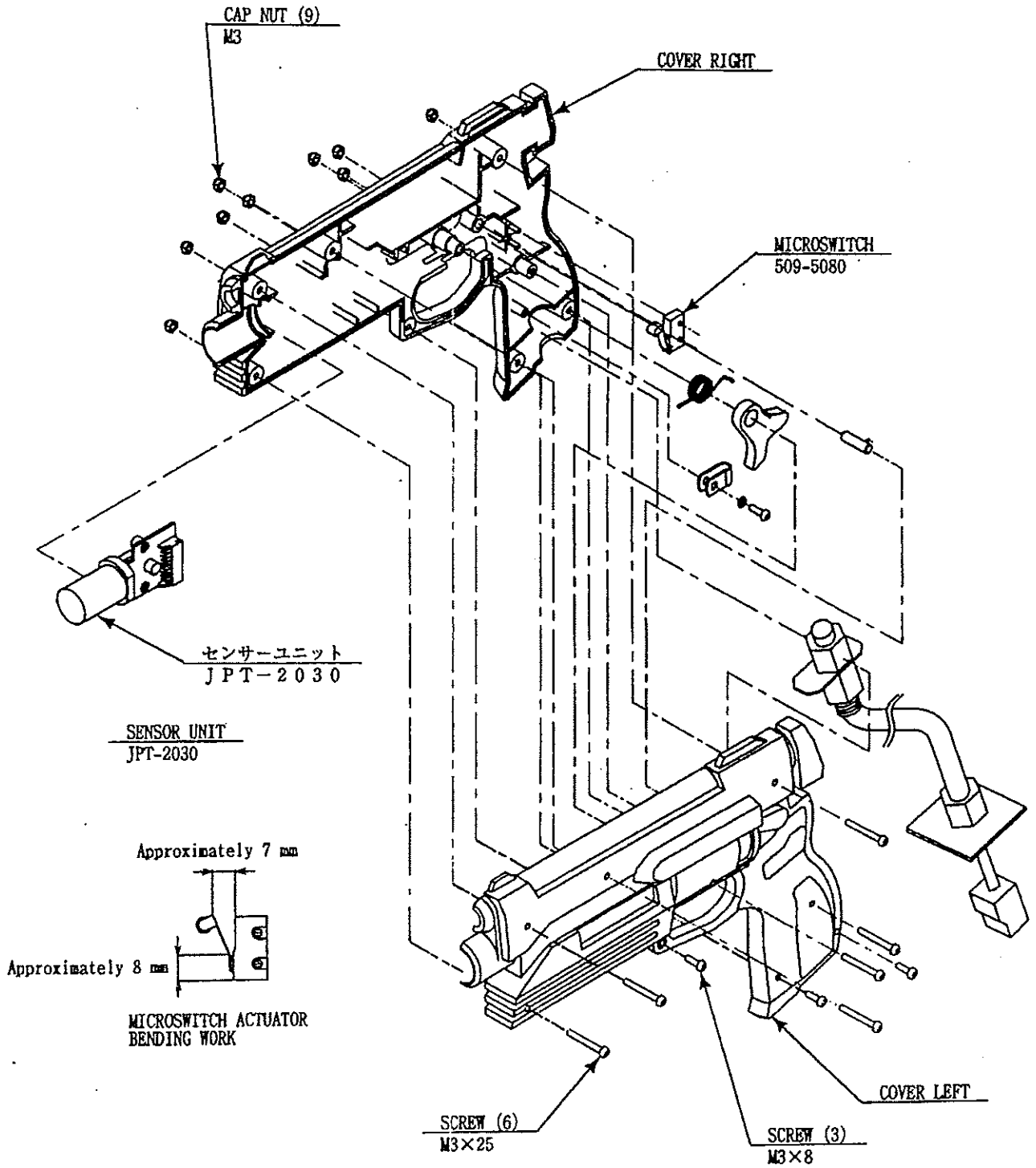

3.13. GAMEBOARD



WARNING!



IMPORTANT!

- Turn off the mains power and remove the power cord before opening the machine.
- To prevent risk of shock or fire, be careful not to damage any wiring.

- The GAME BOARD should not require any work to be carried out upon it. All settings and tests can be achieved without access to the GAME BOARD.
- Take anti-static precautions to avoid damaging the electronic parts.
- All work to be carried out by QUALIFIED SERVICE PERSONNEL

The GD-ROM Service Manual supplied with this product instructs you to remove the Key Chip when shipping the NAOMI Board. However, this product employs a dedicated NAOMI Board, therefore do not disassemble the NAOMI Board or remove the Key Chip.

3.13.1.REMOVING THE BOARD

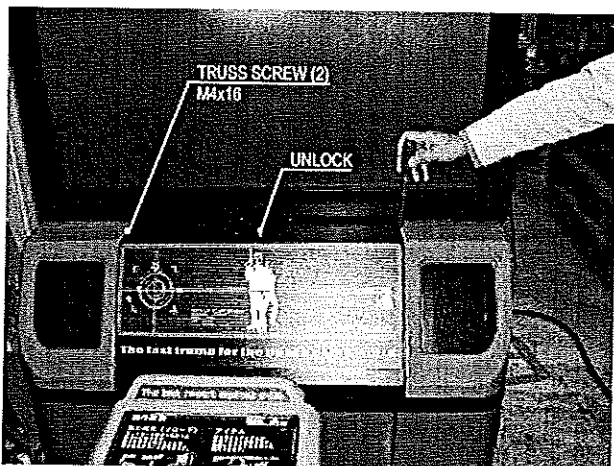

1. Turn off the power.
2. Remove the two screws and unlock the LID UPPER.

3. Disconnect all harnesses connected to the NAOMI Main Board assembly as circled below.

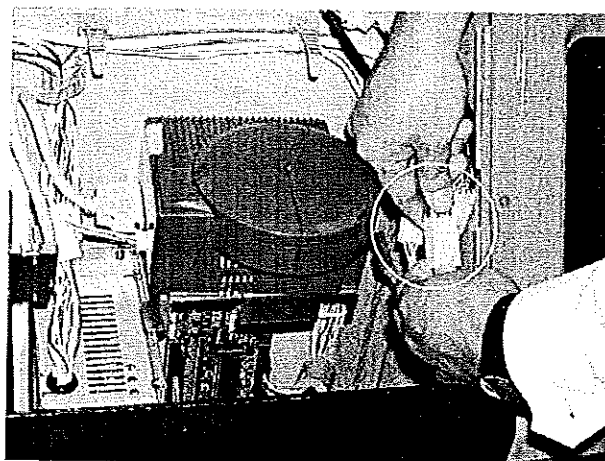
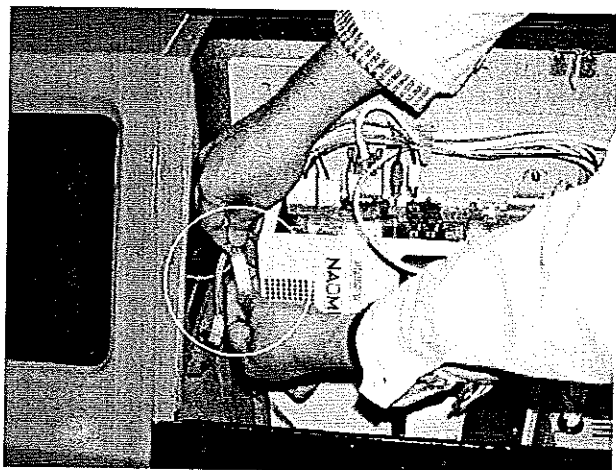

4. Remove the D-SUB connector from the filter board.
5. Remove the two screws securing the base to the cabinet and withdraw the main board assembly upwards out of the cabinet.

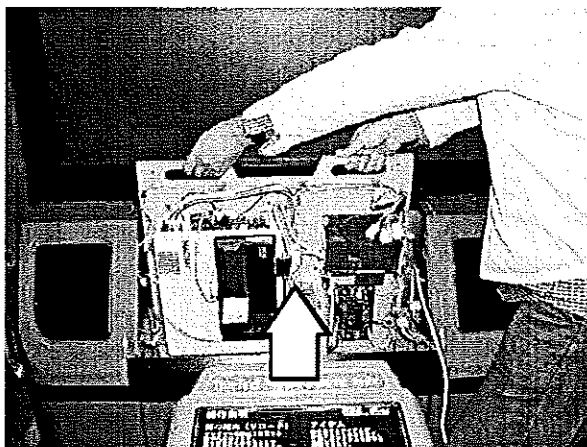
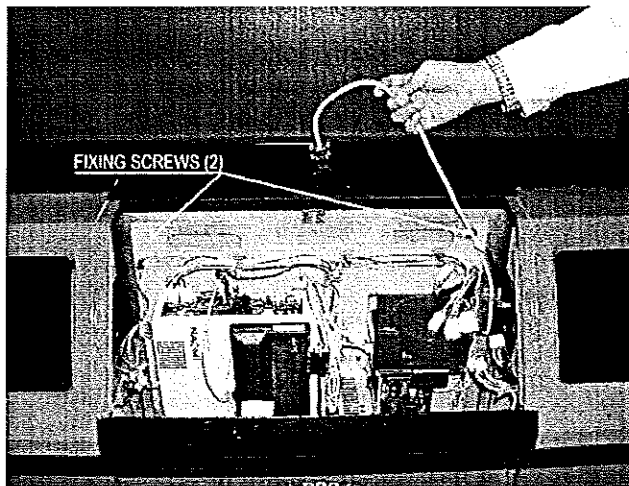

6. Remove all connectors from the filter board of the NAOMI Board. Also remove the GD cable connector from the DIMM Board.
7. Remove four screws securing the NAOMI Board to the base.

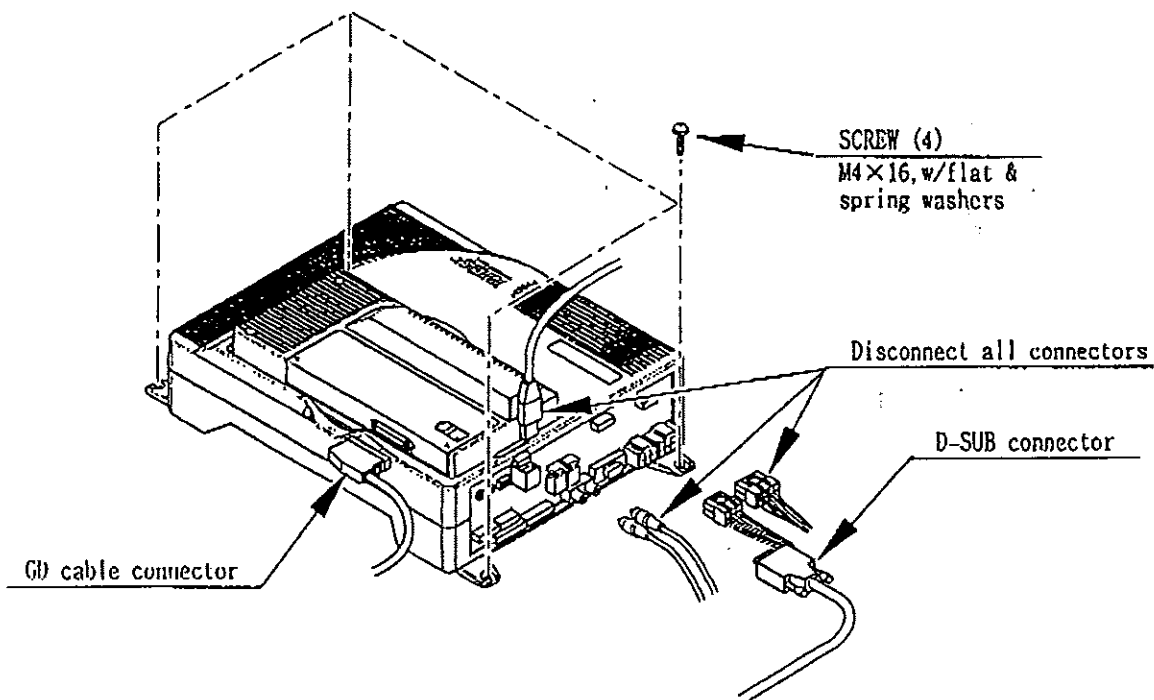

3.13.2.REMOVING THE GD-ROM DRIVE

Take out the ASSY MAIN BD from the PTV cabinet and remove the GD-ROM Drive from the ASSY MAIN BD as follows:

1. Following the above procedure (steps 1 to 5), take out the ASSY MAIN BD.
2. Remove the GD cable connector and the power cord connector from the GD-ROM Drive.

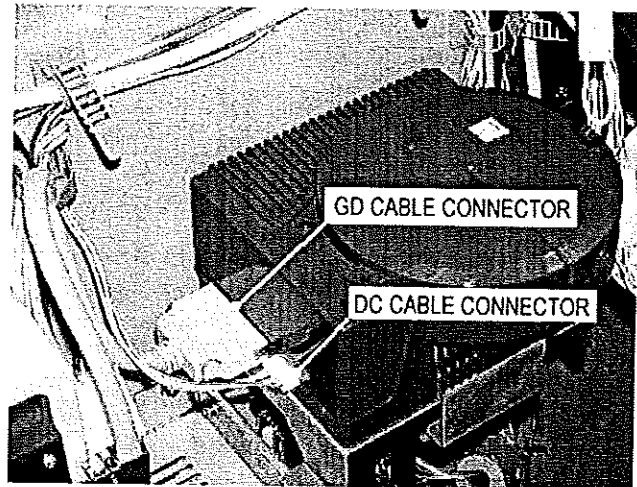

3. To remove the GD-ROM Drive, undo the four screws shown.

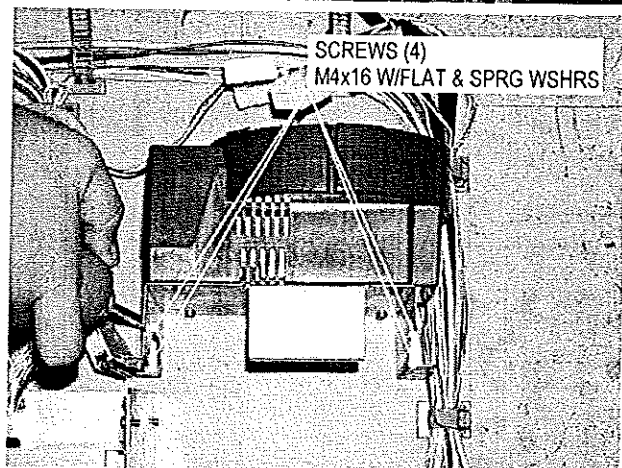

3.14. COMPOSITION OF THE GAME BOARD

ASSY CASE NAO GD SPY USA (840-0050D-01):USA
 ASSY CASE NAO GD SPY EXP (840-0050D-02):EXPORT
 ASSY CASE NAO GD SPY KOR (840-0050D-03):KOREA
 ASSY CASE NAO GD SPY AUS (840-0050D-04):AUSTRALIA

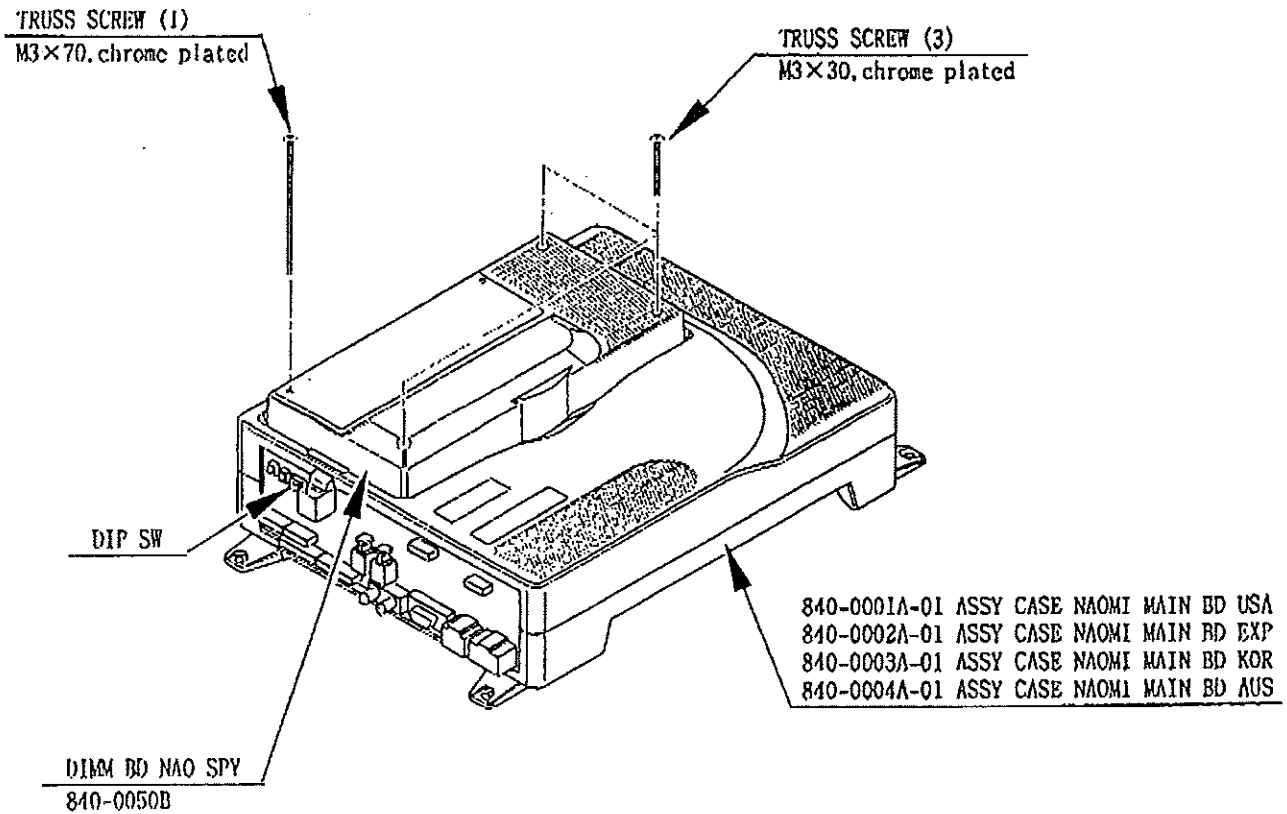

DIP SW SETTING

In this product, set the DIP SW to OFF.

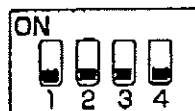

3.15. PERIODIC CHECK AND INSPECTION

The items listed below require periodic check and maintenance to retain the performance of the machine and ensure safe operation:



WARNING!



IMPORTANT!

- Be sure to check annually to see if the power cords are damaged. The plug is securely inserted and that there is no dust in the interior of the machine or between the socket and the power cord. Using the product in an unclean condition may cause a fire or electric shock.

- Periodic checks should only be carried out by **QUALIFIED SERVICE PERSONNEL**.

DESCRIPTION	WHAT TO CHECK	INTERVAL
MONITOR / PROJECTOR	Clean screen	Weekly
	Check adjustment	Monthly
GAME BD	Memory Test	Monthly
	Game Assignments	Monthly
INTERIOR	Clean (Do Not use water jet)	Annually
POWER SUPPLY CORD	Check condition	Annually
CABINET SURFACE	Clean (Do Not use water jet)	As required
CONTROL PANEL	Lamp operation	Monthly
	Check switch operation	Monthly
CONTROLLER (GUN)	Clean	As required
	Check sighting	Weekly
	Check switch operation	Monthly
COIN MECHANISM	Check SW (If Fitted)	Monthly

4. HOW TO PLAY

Use this section to confirm the machine is operating correctly; if the machine doesn't operate as described there may be a fault.

While power is connected, the billboard is continuously lit and demonstration footage and ranking data are displayed on the screen. This 'advertise' mode will be accompanied by sound from both speakers unless set otherwise in the TEST mode.

The 1P and 2P start buttons have integral lights which flash when a credit is inserted.

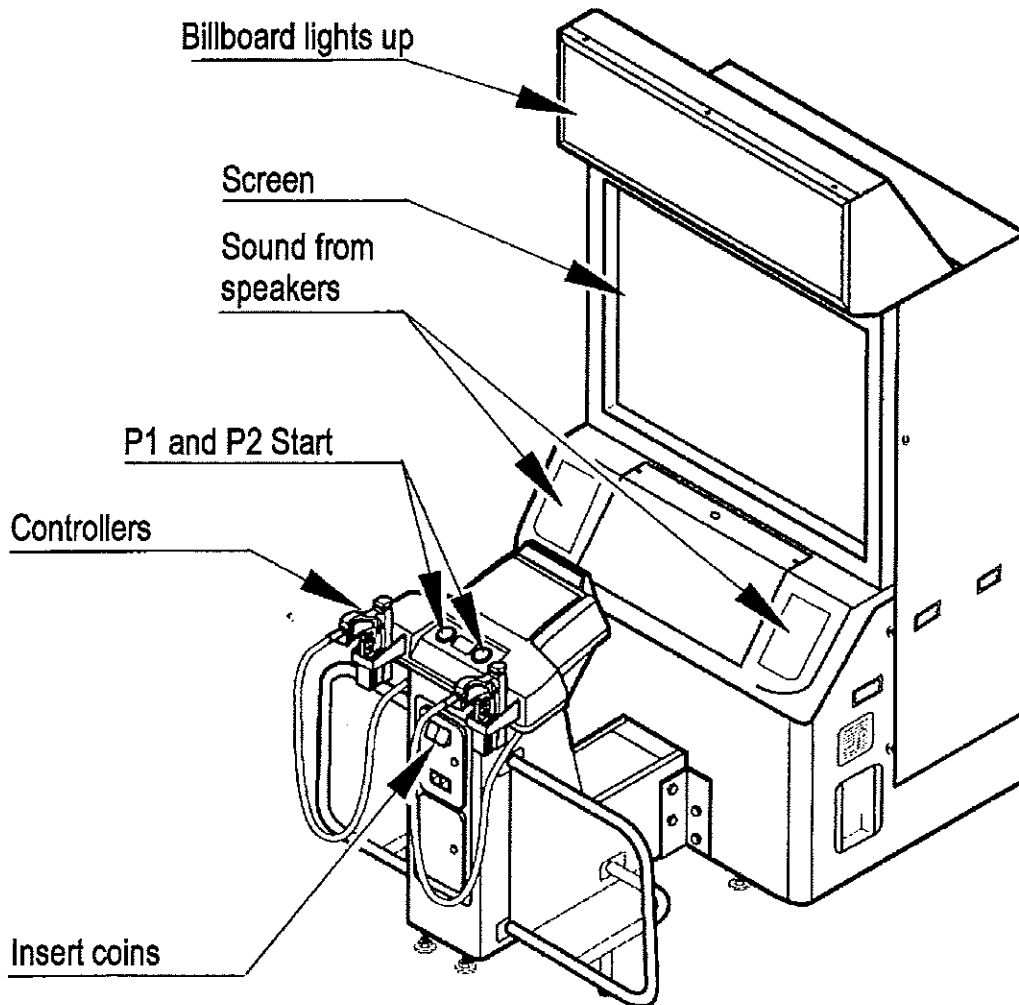

4.1. INTRODUCTION TO THE GAME

Based on a spy story, this is a gun shooting game that enables two players to play simultaneously. The player must, as an agent, shoot enemies to complete missions during each stage. The game comprises of three stages.

- HOWARD GIBSON [agent code: 6] (Player 1)

Nationality: Unknown

Height: 183cm

Hair: Brown

Eyes: Brown

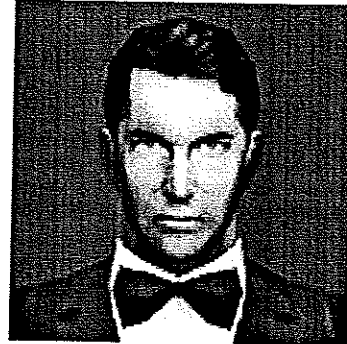

- JEAN CLIFFORD [agent code: 15] (Player 2)

Nationality: Unknown

Height: 172cm

Hair: Blonde

Eyes: Blue



4.1.1. MISSIONS

STAGE 1:

A military satellite has been hijacked by an unknown group. Radio signals to the satellite have been detected and traced to the History Museum. Your mission is to penetrate the Museum's security and collect information.

STAGE 2:

The information reveals the hijackers to be a group called Agares, and they have taken hostage Ms. Illina Mikahailova, one of the development staff. They have forced Illina to modify the satellite's system. Your mission is to rescue her from the train on which she is captive.

STAGE 3:

Ms. Mikahailova has cooperated with you to locate the Agares' base. They have moved the satellite control system to their submarines, and are about to leave the base. You must penetrate the base and recover the control system.

4.2. PLAY INSTRUCTIONS

1. Insert sufficient coins to register the required number of credits to play. The INSERT COIN(S) message disappears and the PRESS START BUTTON message is displayed. At the same time both the start buttons flash.
2. Press either start button, and the following gun adjustment screen is displayed.



Shooting the gun controller at the centre of the target will calibrate the gun system for the player's height/position.

3. After gun adjustment, a screen will be displayed that explains the mission.
4. Another player may join the game in progress by inserting the required value of coins and pressing the unused start button, which will then flash (if it is already flashing there are already enough credits to play). Press again to join the game.

NOTE: A player cannot join the game while the PLEASE WAIT A MINUTE message is being displayed.

5. When all life points have been used, the game is over unless the player continues by adding further coins and pressing start before the timer reaches zero (if the start button is already flashing there are sufficient credits in the system to continue).
6. Players scoring enough points to place in the top 20 can enter their name in the Internet ranking mode (see section 4.2.8).

4.2.1. GAME SCREEN

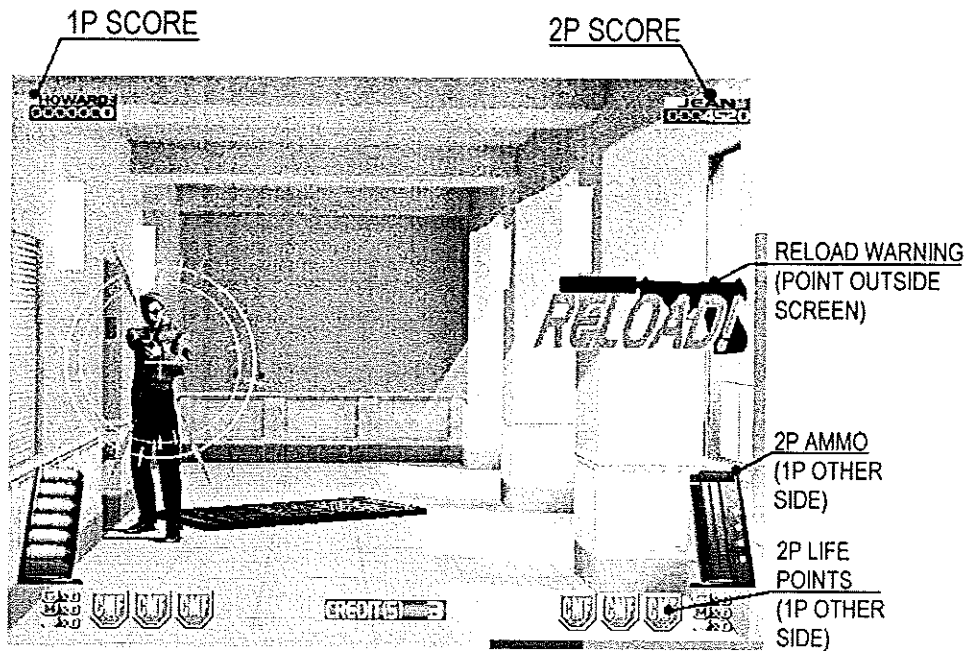

The loaded bullets and remaining life for P1 is shown on the left of the screen; P2 is shown on the right.

4.2.2. RELOADING BULLETS

The 'magazine' holds six bullets; once the magazine is empty, reload by aiming the controller outside the screen and pull the trigger. This message will be displayed when the gun requires reloading.

RELOAD!

4.2.3. GAME OVER

The game is over when:

- All life points are used,
- Stage 3 is cleared.

4.2.4. LOSING LIFE POINTS

- As enemy soldiers armed with grenades, bombs, knives, etc., appear, they are accompanied by a crosshair (shown at right). Shoot the soldier before the crosshair turns red, otherwise a life point will be lost.
- Shoot missiles thrown by enemy soldiers (grenades, etc.), before they reach you, otherwise a life point will be lost.
- A knife attacker should be shot before he makes contact or a life point will be lost.
- Life points are also lost if civilians are shot.

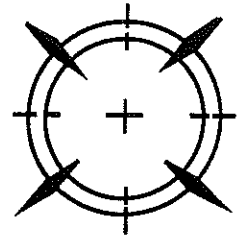

4.2.5. SPECIAL TASKS

Certain tasks are assigned at some points in the game. Completing these tasks successfully will prove beneficial later in the game. If they are failed, the game does not end but the benefits are not gained and the enemy will attack more violently in later stages.

Example:

SHOOTING FROM ROPE SLIDE.

If the task is completed, you enter into pursuit with the enemy boss.

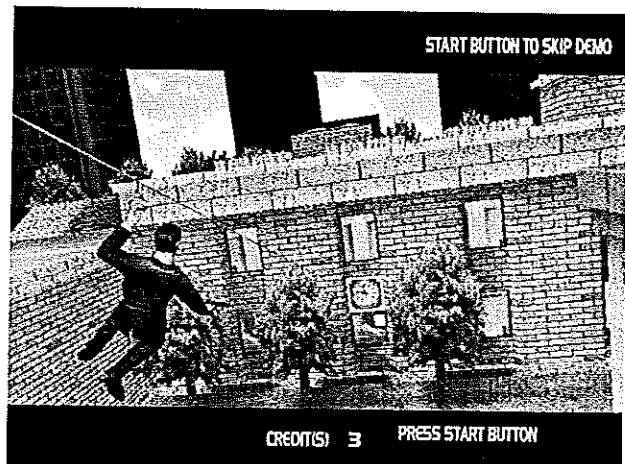

If it is failed, you are attacked and must jump to safety.

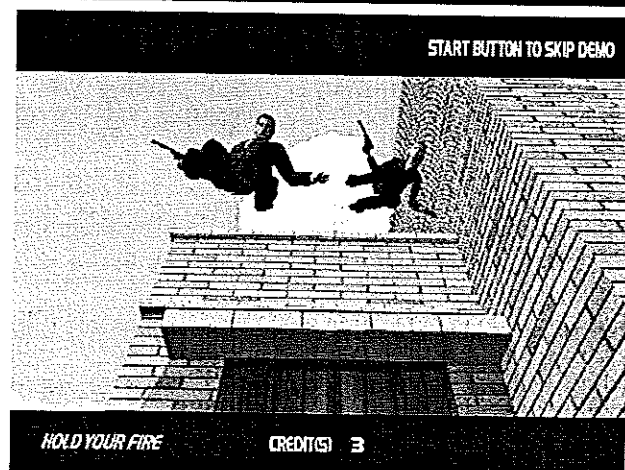

4.2.6. CLEARING THE STAGE

- The end of stage boss must be destroyed to clear the stage.
- The boss is destroyed when the Life Meter reaches zero.

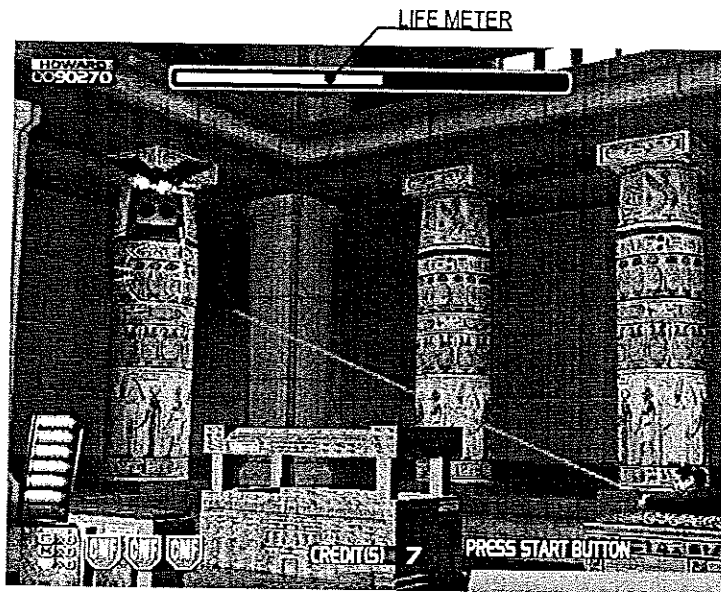

- If the stage is cleared, the MISSION COMPLETE screen is displayed.

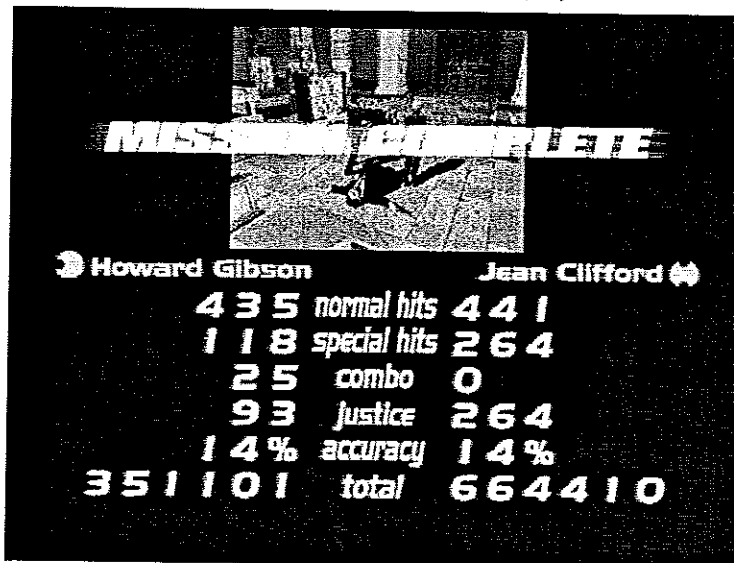

- Normal hits: Indicates the number of hits.
- Special hits: Indicates the total Combo and Justice hits made.
- Combo: Combo hits are made by hitting the enemy more than once before he hits the ground. A maximum of three hits can be made in this way.
- Justice: Justice hits are made by disarming the enemy by shooting the weapon from his hand, thus sparing his life.
- Accuracy: The percentage of shots that were on target.
- Total: The score awarded by combining the above.

4.2.7. AVAILABLE ITEMS

To pick up items, shoot them when they appear on the screen. Picking up items can increase armanents, recover life points or increase scores.

- Life Items

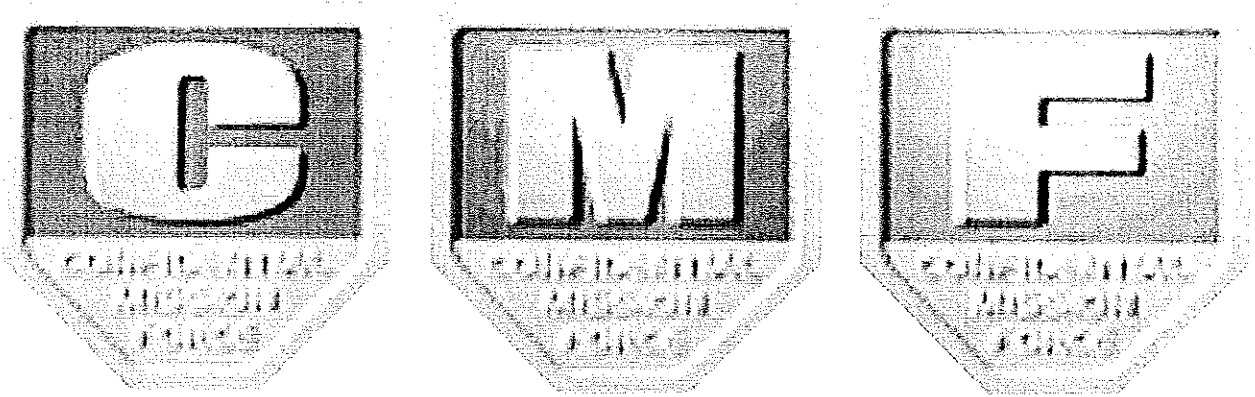

Obtain a complete set of C, M and F marks to gain one life point.

ASSAULT RIFLE

This weapon provides 45 rounds of automatic fire. Once the 45 rounds are spent, the player goes back to the pistol.

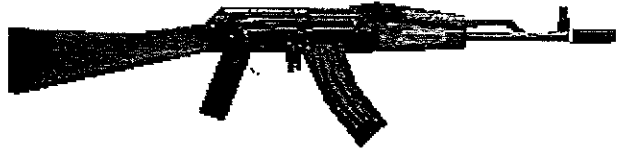

LASER SIGHT

The laser projects a pointer onto the target for a limited time. There isn't a limit on the number of shots that can be fired before the laser sight disappears.

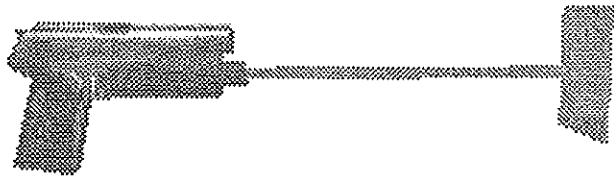

BODY ARMOUR

This item protects the player against one shot from the enemy. It disappears when used once.

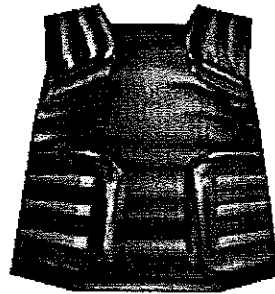

GRENADE

The grenade explodes when shot, causing widespread devastation. Once shot, it disappears.



- POINT ITEMS

ATTACHÉ CASE

Shoot the attaché case for 3,000 points. Once shot, three floppy disks appear (see below).

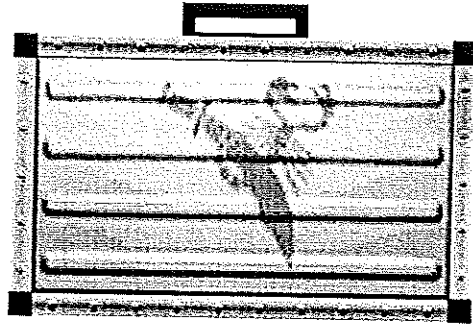

FLOPPY DISK

Shoot these for 5,000 points per disk.

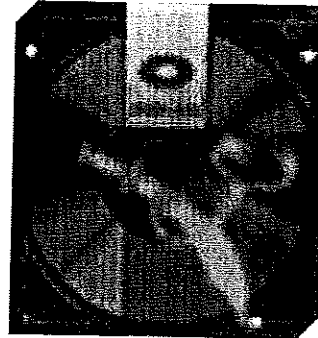

4.2.8. INTERNET RANKING

- If the INTERNET RANKING has been set to ON in GAME ASSIGNMENTS, this message will appear on the advertising display: INTERNET RANKING MODE: PULL TRIGGER AND INSERT COIN.
- To obtain the password for registration in Internet ranking mode:
 - Ensure the Internet ranking is on,
 - Pull the trigger and insert coin as prompted,
 - Enter name.

NOTE: The CONFIDENTIAL MISSION Internet score ranking is operated from the Hitmaker Ltd. home page at <http://www.hitmaker.co.jp>

- When Internet ranking mode is chosen in the above manner, difficulty settings, etc., are overridden and standard settings are substituted.



4.2.9. TIPS FOR HIGH SCORES

- Destroy an enemy as soon as it appears.
Available points are highest when the enemy appears. When its crosshair is red, points are lower.
- Obtain Special Hit bonuses.
By despatching enemies with justice and combo hits. See section 4.2.6.
- Obtain bonuses from clearing special stages.
More points can be had by successfully completing the special stages.

5. MAINTENANCE INSTRUCTIONS

5.1. EXPLANATION OF TEST AND DATA DISPLAY

Use the switches on the VTS to enter the TEST MODE. This will allow you to carry out post installation and periodic checks and adjustments. The following section details the function of each of the tests:



IMPORTANT!

- Be very careful about entering TEST MODE. If the machine you wish to test is linked to other machines, exiting test on your machine will cause a network check to be carried out. This will disable all other machines linked to it.

ITEM	DESCRIPTION / REFERENCES	INTERVAL
INSTALLATION OF THE MACHINE	<p>When the machine is installed perform the following checks:</p> <ul style="list-style-type: none"> • Check to see that each setting is as per the standard settings input at the time of shipment. 3.7.5 • In the INPUT TEST mode, check each switch and 5.2.9.1 • In the OUTPUT TEST mode, check each of the lamps. 5.2.9.2 • In the MEMORY TEST mode check all of the IC's on the IC BD. 5.2.1 	Monthly
MEMORY	<ul style="list-style-type: none"> • On the TEST MENU screen choosing the MEMORY TEST allows self test to be performed. In this test RAM & ROM are tested. 5.2.1 	Monthly
PERIODIC CHECKS	<p>Periodically perform the following</p> <ul style="list-style-type: none"> • MEMORY TEST. 5.2.1 • Ascertain each setting. • In the INPUT TEST mode, test the control devices. 5.2.9.1 • In the OUTPUT TEST mode, check each of the lamps. 5.2.9.2 	Monthly
CONTROL SYSTEM	<ul style="list-style-type: none"> • In the INPUT TEST mode, check each switch and • Adjust or replace each switch and 	Monthly
MONITOR	<ul style="list-style-type: none"> • In the CRT TEST mode, check to ensure the monitor is adjusted correctly. 5.2.4 • Clean screen - (switch off machine and remove the plug). Do not use a water jet. 	Monthly Weekly
IC BOARD	<p>MEMORY TEST</p> <ul style="list-style-type: none"> • In the SOUND TEST mode, check the sound related ROMs. 5.2.3 	Monthly
DATA CHECK	<ul style="list-style-type: none"> • Check such data as held in the bookkeeping screens, relating to number and length of plays. 5.2.11.1 	Monthly
EXTERIOR MAINTENANCE	<ul style="list-style-type: none"> • Clean surfaces 	Monthly
COIN MECHANISM	<ul style="list-style-type: none"> • Check switch operation (if fitted) 	Monthly

5.1.1. VTS ASSEMBLY



- Do not touch places other than those specified. Touching places not specified could cause an electric shock or short circuit.

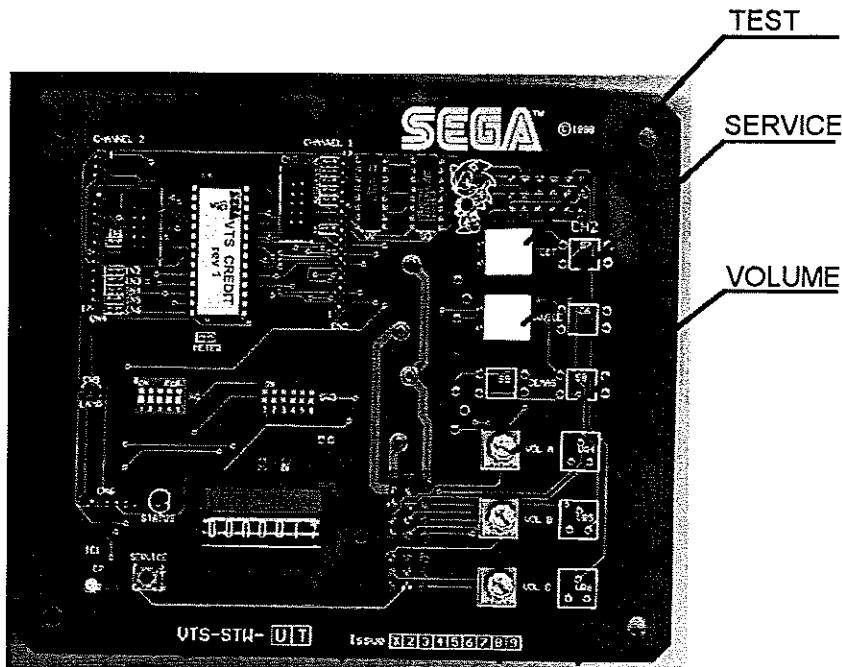

Opening the Coin Chute door will reveal the VTS Assembly shown above. The function of each switch is as follows.

TEST BUTTON
(TEST SW)

Used to enter TEST mode. Also has function during TEST mode. Refer to the later section detailing TEST mode.

SERVICE BUTTON
(SERVICE SW)

Gives credits without registering on the coin counter. Also used during TEST mode.

DEMAG

Eliminates colour unevenness from the monitor screen.

VOLUME CONTROL FRONT

Adjusts the volume of the sound emitted from the speakers.

The control panel switches can also be used in the place of the VTS switches:

Note: There are three volume controls on the VTS, only the top volume control is used, the other two are spares.

5.2. SYSTEM TEST MODE



IMPORTANT!

- Any changes made in SYSTEM TEST MODE will only be stored once the EXIT command is chosen from the SYSTEM MENU. If the power is turned off before this, any changes made are ineffectual.
- Executing BACKUP DATA CLEAR in the SYSTEM TEST MODE does not clear the BOOKKEEPING data in the GAME TEST MODE.
- Entering the SYSTEM TEST MODE clears any coins less than one credit and the BONUS ADDER data.

The SYSTEM TEST MODE mainly allows for IC Board function checks, monitor adjustment, coin assignments, etc. Please also refer to the Monitor Service Manual supplied with this product. The following assignments, however, should be designated as follows for this product:

- CABINET TYPE: 1 PLAYER (S)
- MONITOR TYPE: HORIZONTAL
- COIN CHUTE TYPE: COMMON

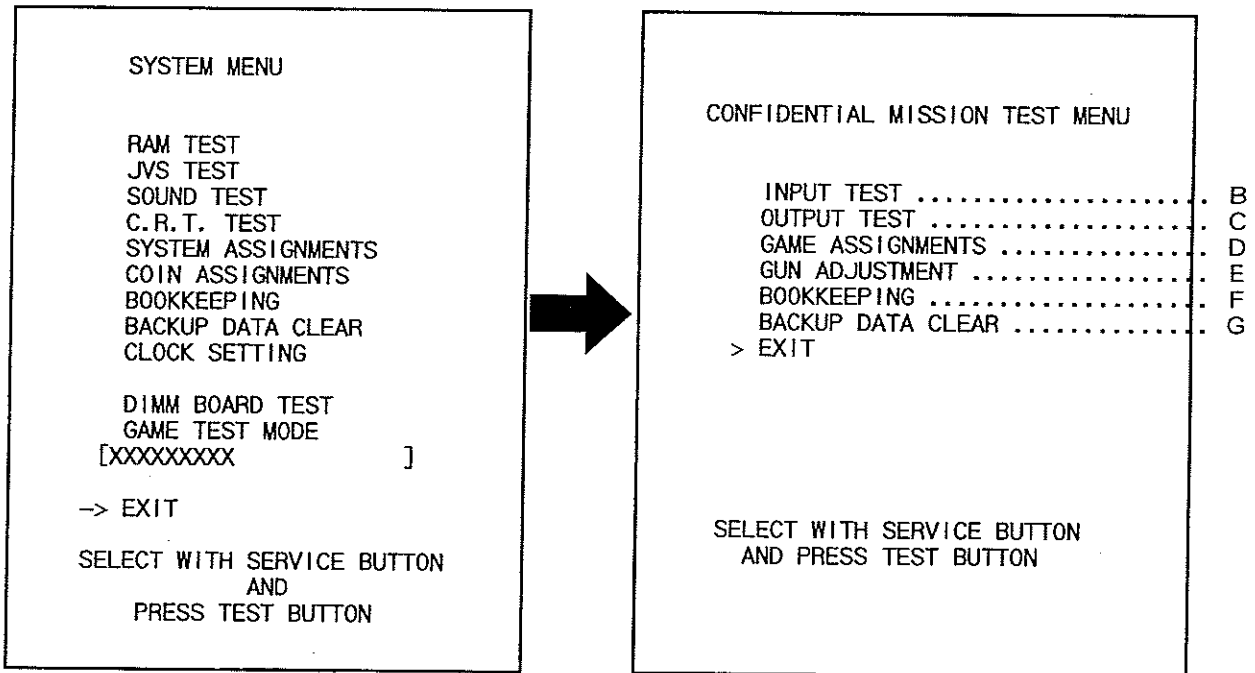

- Press the TEST button to display the SYSTEM TEST MODE MENU.
- By pressing the SERVICE button, move the cursor (->) to the desired item and select with the TEST button.
- Use the SERVICE button to move the cursor and select the desired item with the TEST button.
- Select EXIT once changes are complete and press the TEST button to return to the normal mode.

5.2.1. RAM TEST

This allows the RAM functions to be checked on the Naomi Main Board. 'GOOD' is displayed for satisfactory RAMs, 'BAD' is displayed if any irregularities are found.

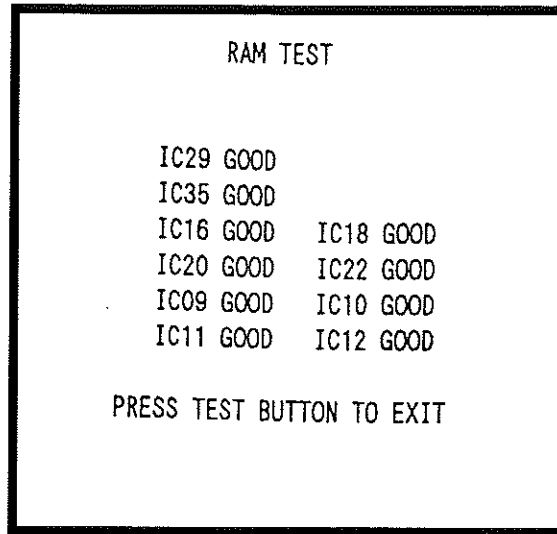

During test, 'TESTING NOW' is displayed. Press the TEST button to return to the Menu Mode.

5.2.2. JVS TEST

In this test, Specifications of the I/O Board connected to NAOMI can be checked, and INPUT TEST can be performed. First, I/O Board Specifications are displayed.

```

                JVS TEST
                INPUT TEST
                NEXT NODE
                -> EXIT
NODE           1/1
NAME          SEGA ENTERPRISES, LTD.
              I/O 838-18683
              VER 1.04
              98/12
CMD VER      1.1
JVS VER      2.0
COM VER      1.0
SWITCH       2PLAYER(S) 11BITS
COIN         2SLOT
ANALOG       8CH
ROTARY       0CH
KEYCODE      0
SCREEN       X:0 Y:0 CH:0
CARD         0SLOT
HOPPER OUT   0CH
DRIVER OUT   8SLOT
ANALOG OUT   0CH
CHARACTER    CHARA:0 LINE:0
BACKUP       0

SELECT WITH SERVICE BUTTON
          AND
PRESS TEST BUTTON
    
```

(A)
(B)
(C)

Name and version of I/O BOARD.

Select with the SERVICE button and press the TEST button.

(A) INPUT TEST: Proceeds to the INPUT TEST of I/O BOARD being displayed.

(B) NEXT NODE: In the case where more than 2 I/O Boards are connected, proceeds to the next I/O Board.

(C) EXIT: Returns to the menu mode.

INPUT TEST SCREEN

```

                JVS TEST
                INPUT TEST
                NEXT NODE
                -> EXIT

NODE 1/1

SWITCH
SYSTEM 00000000
PLAYER1 00000000
        00000000
PLAYER2 00000000
        00000000

COIN
0000 0000
ANALOG
0000 0000 0000 0000
0000 0000 0000 0000

SELECT WITH SERVICE BUTTON
          AND
PRESS TEST BUTTON
    
```

When INPUT is performed for the switches of Control Panel, etc., the value changes to 1 from 0.

If the Coin SW is inputted, the value momentarily changes to 1 from 0.

Analogue values are displayed between 0000 and FF00.

5.2.3. SOUND TEST

Sound Output test can be performed by emitting beeps from each speaker in turn.

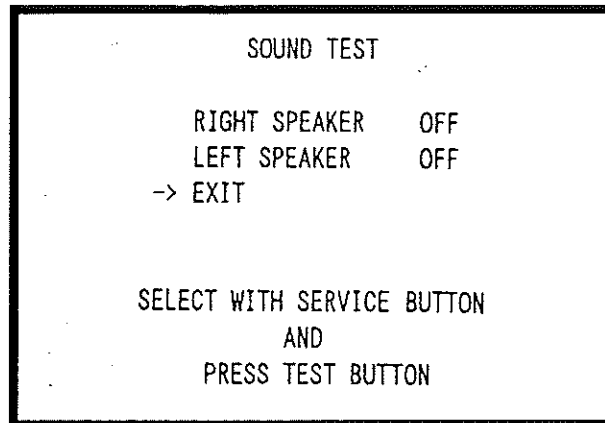

5.2.4. CRT TEST

A) RGB COLOUR ADJUSTMENT SCREEN - Allows monitor colour to be checked.

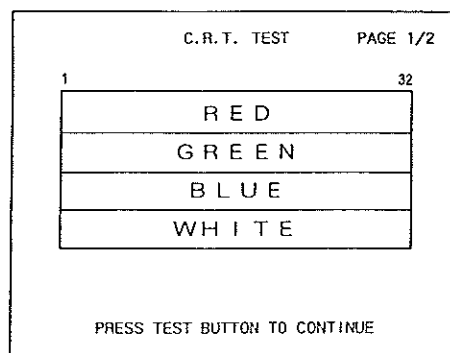

The red, green and blue colour bars are darkest at the leftmost end, becoming brighter towards the right in 31 graduations. Monitor brightness is satisfactory if the white colour bar is black at the leftmost end and white at the rightmost end. Press TEST button to proceed to the next page.

B) MONITOR SIZE ADJUSTMENT SCREEN - Allows monitor size to be checked.

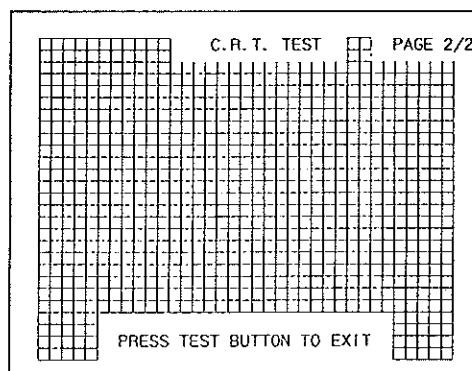

Adjust so that the crosshatches do not go beyond the screen. Press TEST button to return to Menu Mode.

5.2.5. SYSTEM ASSIGNMENTS



IMPORTANT!

- If the **CABINET TYPE** and **MONITOR TYPE** settings are unsuitable for the connected game, an error message is displayed after turning power on and upon finishing TEST mode, and the game is not playable.

Allows cabinet and board settings to be changed. Refer to Section 5.2.10 for changing the game related assignments such as game difficulty. Factory settings are shown in **BOLD** type.

1. Press the SERVICE button to move the cursor to the desired item.
2. Press the TEST button to change the setting.
3. Upon finishing the settings, move the cursor to EXIT and press the TEST button.

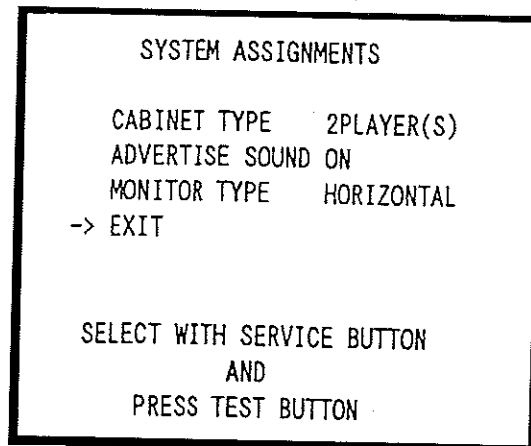

(A) CABINET TYPE (1PLAYER(S), **2PLAYER(S)**, 3PLAYER(S), 4PLAYER(S)) - set the number of players between one and four.

(B) ADVERTISE SOUND (**ON**, OFF) - Set whether ADVERTISE sound is to be emitted or not.

MONITOR TYPE (**HORIZONTAL**, VERTICAL) - sets the on-screen display to the orientation of the monitor. The TEST MODE allows the functioning of each part of the machine to be checked. In addition game configuration and coin configuration changes can be made within TEST MODE.

5.2.5.1.COIN ASSIGNMENTS

COIN ASSIGNMENTS	
COIN CHUTE TYPE	COMMON
CREDIT TO START	2 CREDITS
CONTINUE	1 CREDIT
COIN/CREDIT SETTING # 1	
COIN CHUTE #1	
1 COIN 1 CREDIT	
COIN CHUTE #2	
1 COIN 1 CREDIT	
MANUAL SETTING	
-> EXIT	
SELECT WITH SERVICE BUTTON AND PRESS TEST BUTTON	

In this mode the setting of credit increments against coin insertion can be changed.

1. Press the service button to bring the arrow to the desired item.
2. Press the test button to change the setting.
3. When the settings are completed move the arrow to EXIT and press the TEST button.

COIN CHUTE TYPE (COMMON,INDIVIDUAL)

Set to COMMON

COMMON

Used for the type of cabinet whose coin acceptance is a common type for plural players. Regardless of the number of players COIN1/COIN2 ports are used.

INDIVIDUAL

Not used

CREDIT TO START

Sets the number of credits required to start a game.

CREDIT TO CONTINUE

Sets the number of credits required to continue a game.

CON/CREDIT SETTING (#1~2#27)

Sets the credit increase increment per coin insertion. There are 27 settings from #1 to #26 expressed in #credits as against #coins inserted. #27 refers to FREEPLAY.

5.2.5.2.COIN/CREDIT SETTING (COIN CHUTE COMMON TYPE)

SETTING	FUNCTIONING OF COIN CHUTE #1		FUNCTIONING OF COIN CHUTE #2	
SETTING #1	1 COIN	1 CREDIT	1 COIN	1 CREDIT
SETTING #2	1 COIN	2 CREDITS	1 COIN	1 CREDIT
SETTING #3	1 COIN	3 CREDIT	1 COIN	1 CREDIT
SETTING #4	1 COIN	4 CREDITS	1 COIN	1 CREDIT
SETTING #5	1 COIN	5 CREDITS	1 COIN	1 CREDIT
SETTING #6	1 COIN	2 CREDITS	1 COIN	2 CREDITS
SETTING #7	1 COIN	5 CREDITS	1 COIN	2 CREDITS
SETTING #8	1 COIN	3 CREDITS	1 COIN	3 CREDITS
SETTING #9	1 COIN	4 CREDITS	1 COIN	4 CREDITS
SETTING #10	1 COIN	5 CREDITS	1 COIN	5 CREDITS
SETTING #11	1 COIN	6 CREDITS	1 COIN	6 CREDITS
SETTING #12	2 COINS	1 CREDIT	2 COINS	1 CREDIT
SETTING #13	1 COIN	1 CREDIT	2 COINS	1 CREDIT
SETTING #14	1 COIN	2 CREDITS	2 COINS	1 CREDIT
SETTING #15	1 COIN	1 CREDIT	1 COIN	1 CREDIT
	2 COINS	3 CREDITS	2 COINS	3 CREDITS
SETTING #16	1 COIN	3 CREDITS	1 COIN	1 CREDIT
			2 COINS	3 CREDITS
SETTING #17	3 COINS	1 CREDIT	3 COINS	1 CREDIT
SETTING #18	4 COINS	1 CREDIT	4 COINS	1 CREDIT
SETTING #19	1 COIN	1 CREDIT	1 COIN	1 CREDIT
	2 COINS	2 CREDITS	2 COINS	2 CREDITS
	3 COINS	3 CREDITS	3 COINS	3 CREDITS
	4 COINS	5 CREDITS	4 COINS	5 CREDITS
SETTING #20	1 COIN	5 CREDITS	1 COIN	1 CREDIT
			2 COINS	2 CREDITS
			3 COINS	3 CREDITS
			4 COINS	5 CREDITS
SETTING #21	5 COINS	1 CREDIT	5 COINS	1 CREDIT
SETTING #22	1 COIN	2 CREDITS	3 COINS	1 CREDIT
			5 COINS	2 CREDITS
SETTING #23	2 COINS	1 CREDIT	2 COINS	1 CREDIT
	4 COINS	2 CREDITS	4 COINS	2 CREDITS
	5 COINS	3 CREDITS	5 COINS	3 CREDITS
SETTING #24	1 COIN	3 CREDITS	2 COINS	1 CREDIT
			4 COINS	2 CREDITS
			5 COINS	3 CREDITS
SETTING #25	1 COIN	1 CREDIT	1 COIN	1 CREDIT
	2 COINS	2 CREDITS	2 COINS	2 CREDITS
	3 COINS	3 CREDITS	3 COINS	3 CREDITS
	4 COINS	4 CREDITS	4 COINS	4 CREDITS
	5 COINS	6 CREDITS	5 COINS	6 CREDITS
SETTING #26	1 COIN	6 CREDITS	1 COIN	1 CREDIT
			2 COINS	2 CREDITS
			3 COINS	3 CREDITS
			4 COINS	4 CREDITS
			5 COINS	6 CREDITS
SETTING #27	FREE PLAY		FREE PLAY	

5.2.5.3.MANUAL SETTING

COIN ASSIGNMENTS	
MANUAL SETTING	
COIN TO CREDIT	1 COIN 1 CREDIT
BONUS ADDER	NO BONUS ADDER
COIN CHUTE #1 MULTIPLIER	
1 COIN COUNT AS 1 COIN	
COIN	1 2 3 4 5 6 7 8 9
CREDIT	1 2 3 4 5 6 7 8 9
COIN CHUTE #2 MULTIPLIER	
1 COIN COUNT AS 1 COIN	
COIN	1 2 3 4 5 6 7 8 9
CREDIT	1 2 3 4 5 6 7 8 9
-> EXIT	
SELECT WITH SERVICE BUTTON AND PRESS TEST BUTTON	

The credits incremental increase settings as against coin insertion are shown in more detail than above. Note that when this MANUAL setting is performed the COIN/CREDIT setting becomes ineffective.

COIN TO CREDIT

Determines COIN/CREDIT setting.

BONUS ADDER

This sets how many COINS should be inserted to obtain one service coin.

COIN CHUTE #1/#2 MULTIPLIER

This sets how many tokens one coin represents.

MANUAL SETTING

COIN TO CREDIT	1 COIN	1 CREDIT
	2 COINS	1 CREDIT
	3 COINS	1 CREDIT
	4 COINS	1 CREDIT
	5 COINS	1 CREDIT
	6 COINS	1 CREDIT
	7 COINS	1 CREDIT
	8 COINS	1 CREDIT
	9 COINS	1 CREDIT

BONUS ADDER	NO BONUS ADDER
	2 COINS GIVE 1 EXTRA COIN
	3 COINS GIVE 1 EXTRA COIN
	4 COINS GIVE 1 EXTRA COIN
	5 COINS GIVE 1 EXTRA COIN
	6 COINS GIVE 1 EXTRA COIN
	7 COINS GIVE 1 EXTRA COIN
	8 COINS GIVE 1 EXTRA COIN
	9 COINS GIVE 1 EXTRA COIN

COIN CHUTE MULTIPLIER	1 COIN COUNTS AS 1 COIN
	1 COIN COUNTS AS 2 COINS
	1 COIN COUNTS AS 3 COINS
	1 COIN COUNTS AS 4 COINS
	1 COIN COUNTS AS 5 COINS
	1 COIN COUNTS AS 6 COINS
	1 COIN COUNTS AS 7 COINS
	1 COIN COUNTS AS 8 COINS
	1 COIN COUNTS AS 9 COINS

5.2.6. BOOKKEEPING

Selecting this mode allows the BOOKKEEPING data to be accessed via a sequence of two pages. Press the TEST button is pressed, the following page appears. On the third page, pressing the TEST button re-enters the MENU mode.

```
BOOKKEEPING 1/2

TOTAL TIME
OD 00H 00M 00S

CREDIT 1          0
CREDIT 2          0

COIN 1            0
COIN 2            0

TOTAL COIN        0
COIN CREDIT       0
SERVICE CREDIT   0
TOTAL CREDIT      0

PRESS TEST BUTTON TO CONTINUE
```

Number of items displayed depends on the setting of CABINET TYPE in SYSTEM ASSIGNMENTS.

```
BOOKKEEPING 2/2

P1 SEQ 1  0      P2 SEQ 1  0
P1 SEQ 2  0      P2 SEQ 2  0
P1 SEQ 3  0      P2 SEQ 3  0
P1 SEQ 4  0      P2 SEQ 4  0
P1 SEQ 5  0      P2 SEQ 5  0
P1 SEQ 6  0      P2 SEQ 6  0
P1 SEQ 7  0      P2 SEQ 7  0
P1 SEQ 8  0      P2 SEQ 8  0

P3 SEQ 1  0      P4 SEQ 1  0
P3 SEQ 2  0      P4 SEQ 2  0
P3 SEQ 3  0      P4 SEQ 3  0
P3 SEQ 4  0      P4 SEQ 4  0
P3 SEQ 5  0      P4 SEQ 5  0
P3 SEQ 6  0      P4 SEQ 6  0
P3 SEQ 7  0      P4 SEQ 7  0
P3 SEQ 8  0      P4 SEQ 8  0

PRESS TEST BUTTON TO EXIT
```

5.2.7. BACKUP DATA CLEAR

This allows the BOOKKEEPING data to be cleared. The GAME ASSIGNMENTS settings, and the contents of BOOKKEEPING in the SYSTEM TEST mode are unaffected by this command.

```
BACKUP DATA CLEAR
  YES (CLEAR)
-> NO (CANCEL)

SELECT WITH SERVICE BUTTON
AND PRESS TEST BUTTON
```

When clearing, use the SERVICE BUTTON to bring the cursor to YES (CLEAR) and press the TEST BUTTON. When the data has been cleared, COMPLETED will be displayed.

If clearing of data is not desired, select NO (CANCEL) to return to the MENU MODE.

5.2.8. CLOCK SETTING

This allows YEAR, MONTH, DAY, HOUR and MINUTE settings to be made.

```
CLOCK SETTING
1998 12/02 14:30 33 WED
  YEAR
  MONTH
  DAY
  HOUR
  MINUTE
-> EXIT
SELECT WITH SERVICE BUTTON
AND
PRESS TEST BUTTON
```

Select the desired item with the SERVICE button and press the TEST button to increase the value. Upon finishing the SETTING, bring the cursor to EXIT and press the TEST button to return to the Menu Mode.

5.2.9. GAME TEST MODE

5.2.9.1.INPUT TEST

INPUT TEST		
	PLAYER 1	PLAYER 2
TRIGGER	OFF	OFF
SCREEN-IN	OUT	OUT
GUN-X	0	0
GUN-Y	0	0
START	OFF	OFF

PRESS TEST AND SERVICE BUTTON
TO EXIT

This allows all of the switches and guns to be tested for operation.

Press each switch/trigger in turn to cause the display to change from off to on.

GUN-X and GUN-Y show position of gun when pointed at screen

SCREEN-IN changes from OUT to IN when gun is pointed at screen

5.2.9.2. OUTPUT TEST

OUTPUT TEST	
PLAYER 1	PLAYER 2
> EXIT	

SELECT WITH SERVICE BUTTON
AND PRESS TEST BUTTON

- **PLAYER 1 START LAMP:** To check this, select PLAYER 1 and press the TEST button. PLAYER 1 START button will light up.
- **PLAYER 2 START LAMP:** To check this, select PLAYER 2 and press the TEST button. PLAYER 2 START button will light up.
- **EXIT :** Returns to TEST MENU

5.2.10.GAME ASSIGNMENTS

Use this mode to set certain game parameters. New settings become effective only after exiting the TEST mode completely.

GAME ASSIGNMENTS							
	EASY					HARD	
GAME DIFFICULTY	■	■	■	■	□	□	□
BOSS DIFFICULTY	■	■	■	■	□	□	□
SHIFTING DIFFICULTY	■	■	■	■	□	□	□
	NORMAL					LARGE	
COLLISION SIZE	■	■	■	□	□	□	□
LIFE				3			
ADVERTISE CLOCK				ON			
GUN ADJUST MODE				ON			
INTERNET RANKING				ON			
CABINET TYPE				×	×	×	×
> EXIT							
SELECT WITH SERVICE BUTTON AND PRESS TEST BUTTON							

- **GAME DIFFICULTY:** Select from eight levels of game difficulty.
- **BOSS DIFFICULTY:** Eight levels, affects the difficulty in defeating the stage's boss.
- **SHIFTING DIFFICULTY:** Eight levels, affects how the difficulty increases as the game progresses.
- **COLLISION SIZE:** Eight levels, affects the severity of colliding with an enemy.
- **LIFE:** Select how many lives are awarded at the beginning of the game, from three to eight.
- **ADVERTISE CLOCK:** Select whether a clock is shown during ADVERTISE mode.
- **GUN ADJUST MODE:** Select whether the GUN CONTROLLER ADJUST screen is shown at the beginning of the game.
- **INTERNET RANKING:** Select whether the Internet score ranking mode is active (running on the Hitmaker Ltd. home page). If set to ON, the following message appears on the upper section of the advertise screen: "INTERNET RANKING MODE: PULL TRIGGER AND INSERT COIN". In this instance, pull the trigger and insert coins to activate Internet score ranking mode. At the end of the game the system displays your password that is used to register the score on the web site. When in this mode, the system sets all the difficulty settings to a standard for the ranking mode.
- **CABINET TYPE:** Indicates the type of cabinet used: DELUXE (DX TYPE) or STANDARD (U/R TYPE).

5.2.11.GUN ADJUSTMENT

Select GUN ADJUSTMENT from the CONFIDENTIAL MISSION TEST MENU. The screen below will be displayed. This screen is used to reset the five correction parameters, namely the centre and right/left/top/bottom extremities of the screen. Follow the procedure to make these settings, ensuring that the controller is pointed at these points to decide each correction value.

Press 1P or 2P Start to select each correction parameter.

New settings only become active once the TEST menu has been correctly exited.

GUN ADJUSTMENT																																																													
<table style="width: 100%;"> <thead> <tr> <th colspan="3" style="text-align: left;">PLAYER1</th> </tr> <tr> <th style="width: 10%;"></th> <th style="width: 30%;">OLD</th> <th style="width: 30%;">NOW</th> </tr> </thead> <tbody> <tr> <td>> RIGHT</td> <td>aa</td> <td>bb</td> </tr> <tr> <td>LEFT</td> <td>aa</td> <td>bb</td> </tr> <tr> <td>TOP</td> <td>aa</td> <td>bb</td> </tr> <tr> <td>BOTTOM</td> <td>aa</td> <td>bb</td> </tr> <tr> <td>CENTER X</td> <td>aa</td> <td>bb</td> </tr> <tr> <td> Y</td> <td>aa</td> <td>bb</td> </tr> <tr> <td>DEFAULT</td> <td></td> <td></td> </tr> <tr> <td>CHECK</td> <td></td> <td></td> </tr> </tbody> </table>	PLAYER1				OLD	NOW	> RIGHT	aa	bb	LEFT	aa	bb	TOP	aa	bb	BOTTOM	aa	bb	CENTER X	aa	bb	Y	aa	bb	DEFAULT			CHECK			<table style="width: 100%;"> <thead> <tr> <th colspan="3" style="text-align: left;">PLAYER2</th> </tr> <tr> <th style="width: 10%;"></th> <th style="width: 30%;">OLD</th> <th style="width: 30%;">NOW</th> </tr> </thead> <tbody> <tr> <td>> RIGHT</td> <td>aa</td> <td>bb</td> </tr> <tr> <td>LEFT</td> <td>aa</td> <td>bb</td> </tr> <tr> <td>TOP</td> <td>aa</td> <td>bb</td> </tr> <tr> <td>BOTTOM</td> <td>aa</td> <td>bb</td> </tr> <tr> <td>CENTER X</td> <td>aa</td> <td>bb</td> </tr> <tr> <td> Y</td> <td>aa</td> <td>bb</td> </tr> <tr> <td>DEFAULT</td> <td></td> <td></td> </tr> <tr> <td>CHECK</td> <td></td> <td></td> </tr> </tbody> </table>	PLAYER2				OLD	NOW	> RIGHT	aa	bb	LEFT	aa	bb	TOP	aa	bb	BOTTOM	aa	bb	CENTER X	aa	bb	Y	aa	bb	DEFAULT			CHECK		
PLAYER1																																																													
	OLD	NOW																																																											
> RIGHT	aa	bb																																																											
LEFT	aa	bb																																																											
TOP	aa	bb																																																											
BOTTOM	aa	bb																																																											
CENTER X	aa	bb																																																											
Y	aa	bb																																																											
DEFAULT																																																													
CHECK																																																													
PLAYER2																																																													
	OLD	NOW																																																											
> RIGHT	aa	bb																																																											
LEFT	aa	bb																																																											
TOP	aa	bb																																																											
BOTTOM	aa	bb																																																											
CENTER X	aa	bb																																																											
Y	aa	bb																																																											
DEFAULT																																																													
CHECK																																																													
SIGHT OUT																																																													
SELECT WITH START BUTTON AND PULL TRIGGER																																																													
PRESS TEST BUTTON TO EXIT																																																													

- RIGHT aa bb Decides a horizontal correction value at the right end. The aa column indicates the values before resetting; the bb column is the value after setting.

Aim the controller at the square mark at the right of the 'crosshair' and pull the trigger to determine the correction value.

Vertical correction need not be considered at this point.
- LEFT aa bb Decides a horizontal correction value at the left end. The aa column indicates the values before resetting; the bb column is the value after setting.

Aim the controller at the square mark at the left of the 'crosshair' and pull the trigger to determine the correction value.

Vertical correction need not be considered at this point.
- TOP aa bb Decides a vertical correction value at the top end. The aa column indicates the values before resetting; the bb column is the value after setting.

Aim the controller at the square mark at the top of the 'crosshair' and pull the trigger to determine the correction value.

Horizontal correction need not be considered at this point.
- BOTTOM aa bb Decides a vertical correction value at the bottom end. The aa column indicates the values before resetting; the bb column is the value after setting.

Aim the controller at the square mark at the bottom of the 'crosshair' and pull the trigger to determine the correction value.

Horizontal correction need not be considered at this point.
- CENTER X (Y) aa bb Decides a correction value at the centre. X indicates a horizontal direction while Y indicates a vertical direction. The aa column indicates the values before resetting; the bb column is the value after setting.

Aim the controller at the square mark in the centre of the 'crosshair' and pull the trigger to determine the correction value.

- **DEFAULT** Selecting this will put the values back to those before resetting.
- **CHECK** Selecting CHECK will result in a round cursor (red for 1P and blue for 2P) on the screen corresponding to where the gun is aimed. Refer to the cursor before making adjustments.
- **SIGHT OUT** This message appears when the gun is pointed outside the screen.

5.2.11.1. BOOKKEEPING

```

BOOKKEEPING 1/2

NUMBER OF GAMES           0
TOTAL (POWER ON) TIME    00H 00M 00S
GAME TIME                 00H 00M 00S
PLAY TIME                 00H 00M 00S
AVERAGE PLAY TIME       00H 00M 00S
LONGEST PLAY TIME        00H 00M 00S
SHORTEST PLAY TIME       00H 00M 00S

PRESS TEST BUTTON TO CONTINUE

```

- **NUMBER OF GAMES** Total number of plays.
- **TOTAL (POWER ON) TIME** Accumulated power-on hours.
- **GAME TIME** Accumulated operation hours.
- **PLAY TIME** Accumulated playing hours (1P+2P).

```

BOOKKEEPING 2/2

TIME HISTOGRAM
0M00S - 0M29S  0
0M30S - 0M59S  0
1M00S - 1M29S  0
1M30S - 1M59S  0
2M00S - 2M29S  0
2M30S - 2M59S  0
3M00S - 3M29S  0
3M30S - 3M59S  0
4M00S - 4M29S  0
4M30S - 4M59S  0
5M00S - 5M29S  0
5M30S - 5M59S  0
6M00S - 6M29S  0
6M30S - 6M59S  0
7M00S - 7M29S  0
7M30S - 7M59S  0
8M00S - 8M29S  0
8M30S - 8M59S  0
9M00S - 9M29S  0
9M30S - 9M59S  0
OVER 10M00S   0

PRESS TEST BUTTON TO EXIT

```

Playing frequency bookkeeping is displayed in increments of 30 seconds from 0M00S to 9M59S. Playtime in excess of 10 minutes is displayed in the category of OVER 10M00S.

5.2.11.2.BACKUP DATA CLEAR

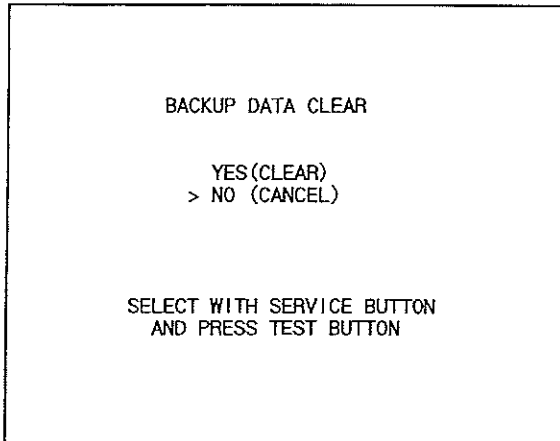

Clears BOOKKEEPING DATA in GAME TEST MODE.

When clearing, bring the arrow to "YES" and press the test button.

Move the arrow to "NO" and press the test button to return to the main menu.

6. COIN MECH INSTALLATION AND CREDIT BOARD SET UP

6.1. INTRODUCTION

Game credits between the Coin Mechanism and the game board for this machine are controlled by a VTS board. This electronic circuit allows the price of play to be set for a range of different countries. These functions are set on Dual In Line (DIL) PCB mounted switches.

SW1 is used to set the currency (or coin ratio) and SW3 the price of play. Refer to the Tables on the following pages for the correct settings for your environment.

The VTS board pictured below is mounted in the Coin Chute Tower.

The VTS board is connected to the coin validator and lamps via a dedicated wiring harness depending upon the coin validator used:

Wiring Harness	Validator	
LM1006	Coin Controls	(15 way connector)
LM1007	Mars	(13 way connector)
LM1008	Mechanical	See note 2
N/A	NRI	See note 1

Notes

1. If NRI mechanisms are to be used, these should be ordered with the highest denomination coin on coin path #1 and the lowest denomination on coin path #4. The VTS board should be then be set up for either the UK or Switzerland settings. A minimum connecting lead length of 600mm is required.
2. Mechanical coin mechanisms may be connected in parallel allowing two identical mechanisms to be fitted.

The VTS Board

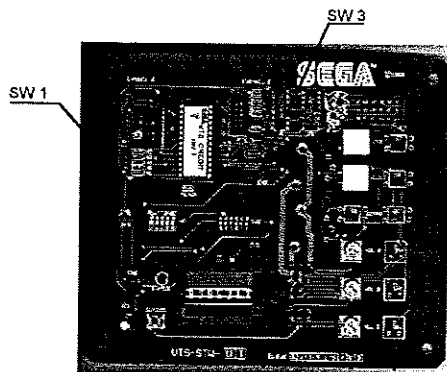

Credit Board Mode Settings Switch 3																			
Country	Setting	Switch 3 Setting						Coin Validator Programming											
		SW1	SW2	SW3	SW4	SW5	SW6	COIN1	COIN2	COIN3	COIN4	COIN5	COIN6	COIN7	COIN8	COIN9	COIN10	COIN11	COIN12
UK	Coin Controls C220 Parallel	OFF	OFF	OFF	OFF			£1	50p new	20p	10p	-	50p old	-	-				
UK	Coin Controls C220 Binary	ON	OFF	OFF	OFF			£1	50p new	20p	10p	-	50p old	-	£2				
UK	Coin Controls C220 Binary	OFF	ON	OFF	OFF			£1	50p new	20p	10p	-	£2	-	50p old				
UK	Coin Controls C120 Parallel	ON	ON	OFF	OFF			£1	50p new	20p	10p	-	£2	-	50p old				
UK	Coin Controls C120 Parallel	OFF	OFF	ON	OFF			£2	£1	50p new	20p	10p	-	-	-	50p old			
UK	Mars ME/MS 111 Parallel	ON	OFF	ON	OFF			£1	£2	20p	10p	50p new	50p old	-	-				
UK	NRI Parallel	OFF	ON	ON	OFF			10p	20p	50p	£1	£2	-	-	-				
Belgium	Parallel	ON	ON	ON	OFF			-	50Bfr	20Bfr	5Bfr								
Holland	Parallel	OFF	OFF	OFF	ON			-	5NLG	2.5NLG	1NLG								
Austria	Parallel	ON	OFF	OFF	ON			20Sch	10Sch	5Sch	1Sch								
Spain	Coin Controls C220 Binary	OFF	ON	OFF	ON			500Pta	200Pta new	100Pta	50Pta	25Pta new	200Pt old	50Pta old	25Pta old				
Spain	C120/NRI Parallel	ON	ON	OFF	ON			500Pta	200Pta old	100Pta	50Pta old	25Pta old	-	-	200Pta old	50Pta old	25Pta old	-	
Spain	Coin Controls C220 Parallel	OFF	OFF	ON	ON			100Pta	50Pta new	-	25Pta new	-	50Pta old	-	25Pta old				
Portugal	Parallel	ON	OFF	ON	ON			200Es	100Es	50Es	-	-	-	-	-				
	TBA				OFF		TBA												
	Channels				ON		TBA												
					OFF		Direct Mode												
					ON		2 channel Mode												

Please Note
The credit board automatically sets the validator for parallel and binary operation through an output on pin 8 of the 17 way pinstrip. For the feature to work it is necessary for the validator interconnecting cable to include at wire at this position

Note: These switch settings are under constant review and may change due to world currency updates.

- Set SW 1 according to the option settings found in the relevant Price of Play Settings Table on the following pages.
- For Germany (DM), France (Fr) & Switzerland (SFr), use the appropriate existing setting shown above (from another country) that matches the coin ratios programmed into your coin me
- Set SW 3 on the VTS board as shown in the table above corresponding to the country required.

6.1.1. PRICE OF PLAY SETTINGS UK

	Price	Bonus			DIL Switch 1				
					Switch 1	Switch 2	Switch 3	Switch 4	Switch 5
1	10p	No Bonus			OFF	OFF	OFF	OFF	OFF
2	10p	6 = 50p			ON	OFF	OFF	OFF	OFF
3	20p	No Bonus			OFF	ON	OFF	OFF	OFF
4	20p	3 = 50p	6 = £1	12 = £2	ON	ON	OFF	OFF	OFF
5	30p	No Bonus			OFF	OFF	ON	OFF	OFF
6	30p	1.66 = 50p	4 = £1	8 = £2	ON	OFF	ON	OFF	OFF
7	30p	2 = 50p	4 = £1		OFF	ON	ON	OFF	OFF
8	30p	AMLD *	3 = £1	6 = £2	ON	ON	ON	OFF	OFF
9	40p	No Bonus			OFF	OFF	OFF	ON	OFF
10	40p	1.25 = 50p	3 = £1	6 = £2	ON	OFF	OFF	ON	OFF
11	50p	No Bonus			OFF	ON	OFF	ON	OFF
12	50p		3 = £1	6 = £2	ON	ON	OFF	ON	OFF
13	50p		2 = £1	5 = £2	OFF	OFF	ON	ON	OFF
14	60p	No Bonus			ON	OFF	ON	ON	OFF
15	60p		2 = £1	4 = £2	OFF	ON	ON	ON	OFF
16	80p	No Bonus			ON	ON	ON	ON	OFF
17	80p	1.25 = £1	2 = £1.50	2.5 = £2	OFF	OFF	OFF	OFF	ON
18	£1	No Bonus			ON	OFF	OFF	OFF	ON
19	£1		3 = £2		OFF	ON	OFF	OFF	ON
20	£1		2 = £2	5 = £4	ON	ON	OFF	OFF	ON
21	£1.50	No Bonus			OFF	OFF	ON	OFF	ON
22	£1.50		2 = £2		ON	OFF	ON	OFF	ON
23	£2	No Bonus			OFF	ON	ON	OFF	ON
24	£2			3 = £5	ON	ON	ON	OFF	ON
25	£3	No Bonus			OFF	OFF	OFF	ON	ON
26	£3			2 = £5	ON	OFF	OFF	ON	ON
27	£5	No Bonus			OFF	ON	OFF	ON	ON
28	£5			3 = £10	ON	ON	OFF	ON	ON
29	£7.50	No Bonus			OFF	OFF	ON	ON	ON
30	£7.50			2 = £10	ON	OFF	ON	ON	ON
31	£10	No Bonus			OFF	ON	ON	ON	ON
32	Free Play				ON	ON	ON	ON	ON

6.1.2. PRICE OF PLAY SETTINGS Austria-Czech-Denmark-Norway-
Israel-France2

	Price	Bonus			Switch 1				
					Switch 1	Switch 2	Switch 3	Switch 4	Switch 5
1	1	No Bonus			OFF	OFF	OFF	OFF	OFF
2	1			11 = 10	ON	OFF	OFF	OFF	OFF
3	1		6 = 5		OFF	ON	OFF	OFF	OFF
4	2	No Bonus			ON	ON	OFF	OFF	OFF
5	2			6 = 10	OFF	OFF	ON	OFF	OFF
6	2		3 = 5		ON	OFF	ON	OFF	OFF
7	3	No Bonus			OFF	ON	ON	OFF	OFF
8	3			4 = 10	ON	ON	ON	OFF	OFF
9	3		2 = 5		OFF	OFF	OFF	ON	OFF
10	4	No Bonus			ON	OFF	OFF	ON	OFF
11	4		3 = 10		OFF	ON	OFF	ON	OFF
12	5	No Bonus			ON	ON	OFF	ON	OFF
13	5			3 = 10	OFF	OFF	ON	ON	OFF
14	6	No Bonus			ON	OFF	ON	ON	OFF
15	6			4 = 20	OFF	ON	ON	ON	OFF
16	8	No Bonus			ON	ON	ON	ON	OFF
17	10	No Bonus			OFF	OFF	OFF	OFF	ON
18	10			3 = 20	ON	OFF	OFF	OFF	ON
19	20	No Bonus			OFF	ON	OFF	OFF	ON
20	20			3 = 50	ON	ON	OFF	OFF	ON
21	30	No Bonus			OFF	OFF	ON	OFF	ON
22	30			2 = 50	ON	OFF	ON	OFF	ON
23	50	No Bonus			OFF	ON	ON	OFF	ON
24	50			3 = 100	ON	ON	ON	OFF	ON
32	Free Play				ON	ON	ON	ON	ON

6.1.3. PRICE OF PLAY SETTINGS - BELGIUM

	Price	Bonus			DIL Switch 1				
					Switch 1	Switch 2	Switch 3	Switch 4	Switch 5
1	5BFr	No Bonus			OFF	OFF	OFF	OFF	OFF
2	5BFr			11 = 50BFr	ON	OFF	OFF	OFF	OFF
3	5BFr		5 = 20BFr		OFF	ON	OFF	OFF	OFF
4	10BFr	No Bonus			ON	ON	OFF	OFF	OFF
5	10BFr			6 = 50BFr	OFF	OFF	ON	OFF	OFF
6	10BFr		3 = 20BFr		ON	OFF	ON	OFF	OFF
7	15BFr	No Bonus			OFF	ON	ON	OFF	OFF
8	15BFr			4 = 50BFr	ON	ON	ON	OFF	OFF
9	15BFr		7 = 100BFr		OFF	OFF	OFF	ON	OFF
10	20BFr	No Bonus			ON	OFF	OFF	ON	OFF
11	20BFr			3 = 50BFr	OFF	ON	OFF	ON	OFF
12	20BFr		3 = 50BFr		ON	ON	OFF	ON	OFF
13	25BFr	No Bonus			OFF	OFF	ON	ON	OFF
14	25BFr			5=100BFr	ON	OFF	ON	ON	OFF
15	25BFr		3 = 50BFr		OFF	ON	ON	ON	OFF
16	30BFr	No Bonus			ON	ON	ON	ON	OFF
17	30BFr			4=100BFr	OFF	OFF	OFF	OFF	ON
18	30BFr		2=50BFr		ON	OFF	OFF	OFF	ON
19	40BFr	No Bonus			OFF	ON	OFF	OFF	ON
20	40BFr			3=100BFr	ON	ON	OFF	OFF	ON
21	50BFr	No Bonus			OFF	OFF	ON	OFF	ON
22	50BFr			3=100BFr	ON	OFF	ON	OFF	ON
23					OFF	ON	ON	OFF	ON
24					ON	ON	ON	OFF	ON
25					OFF	OFF	OFF	ON	ON
26					ON	OFF	OFF	ON	ON
27					OFF	ON	OFF	ON	ON
28					ON	ON	OFF	ON	ON
29					OFF	OFF	ON	ON	ON
30					ON	OFF	ON	ON	ON
31					OFF	ON	ON	ON	ON
32	Free Play				ON	ON	ON	ON	ON

6.1.4. PRICE OF PLAY SETTINGS - FRANCE

	Price	Bonus			DIL Switch 1				
					Switch 1	Switch 2	Switch 3	Switch 4	Switch 5
1	1Fr	No Bonus			OFF	OFF	OFF	OFF	OFF
2	1Fr	6 = 5Fr			ON	OFF	OFF	OFF	OFF
3	2Fr	No Bonus			OFF	ON	OFF	OFF	OFF
4	2Fr	3 = 5Fr	6 = 10Fr	12 = 20Fr	ON	ON	OFF	OFF	OFF
5	3Fr	No Bonus			OFF	OFF	ON	OFF	OFF
6	3Fr	1.66 = 5Fr	4 = 10Fr	8 = 20Fr	ON	OFF	ON	OFF	OFF
7	3Fr	2 = 5Fr	4 = 10Fr		OFF	ON	ON	OFF	OFF
8	3Fr	**	3 = 10Fr	6 = 20Fr	ON	ON	ON	OFF	OFF
9	4Fr	No Bonus			OFF	OFF	OFF	ON	OFF
10	4Fr	1.25 = 5Fr	3 = 10Fr	6 = 20Fr	ON	OFF	OFF	ON	OFF
11	5Fr	No Bonus			OFF	ON	OFF	ON	OFF
12	5Fr		3 = 10Fr	6 = 20Fr	ON	ON	OFF	ON	OFF
13	5Fr		2 = 10Fr	5 = 20Fr	OFF	OFF	ON	ON	OFF
14	6Fr	No Bonus			ON	OFF	ON	ON	OFF
15	6Fr		2 = 10Fr	4 = 20Fr	OFF	ON	ON	ON	OFF
16	8Fr	No Bonus			ON	ON	ON	ON	OFF
17	8Fr	1.25 = 10Fr	2 = 15Fr	2.5 = 20Fr	OFF	OFF	OFF	OFF	ON
18	10Fr	No Bonus			ON	OFF	OFF	OFF	ON
19	10Fr		3 = 20Fr		OFF	ON	OFF	OFF	ON
20	10Fr		2 = 20Fr	5 = 40Fr	ON	ON	OFF	OFF	ON
21	15Fr	No Bonus			OFF	OFF	ON	OFF	ON
22	15Fr		2 = 20Fr		ON	OFF	ON	OFF	ON
23	20Fr	No Bonus			OFF	ON	ON	OFF	ON
24	20Fr			3 = 50Fr	ON	ON	ON	OFF	ON
25	30Fr	No Bonus			OFF	OFF	OFF	ON	ON
26	30Fr			2 = 50Fr	ON	OFF	OFF	ON	ON
27	50Fr	No Bonus			OFF	ON	OFF	ON	ON
28	50Fr			3 = 100Fr	ON	ON	OFF	ON	ON
29	75Fr	No Bonus			OFF	OFF	ON	ON	ON
30	75Fr			2 = 100Fr	ON	OFF	ON	ON	ON
31	100Fr	No Bonus			OFF	ON	ON	ON	ON
32	Free Play				ON	ON	ON	ON	ON

** This is a special setting which gives no credit until a total of 10Fr is input and then gives three games.

6.1.5. PRICE OF PLAY SETTINGS - ITALY

	Price	Bonus			DIL Switch 1				
					Switch 1	Switch 2	Switch 3	Switch 4	Switch 5
1					OFF	OFF	OFF	OFF	OFF
2					ON	OFF	OFF	OFF	OFF
3					OFF	ON	OFF	OFF	OFF
4					ON	ON	OFF	OFF	OFF
5					OFF	OFF	ON	OFF	OFF
6					ON	OFF	ON	OFF	OFF
7					OFF	ON	ON	OFF	OFF
8					ON	ON	ON	OFF	OFF
9					OFF	OFF	OFF	ON	OFF
10	100L	No Bonus			ON	OFF	OFF	ON	OFF
11	100L			6 = 500L	OFF	ON	OFF	ON	OFF
12	100L		3 = 200L		ON	ON	OFF	ON	OFF
13	200L	No Bonus			OFF	OFF	ON	ON	OFF
14	200L			3 = 500L	ON	OFF	ON	ON	OFF
15	200L		3 = 400L		OFF	ON	ON	ON	OFF
16	300L	No Bonus			ON	ON	ON	ON	OFF
17	300L			2 = 500L	OFF	OFF	OFF	OFF	ON
18	300L		3 = 600L		ON	OFF	OFF	OFF	ON
19	400L	No Bonus			OFF	ON	OFF	OFF	ON
20	400L			3 = 1000L	ON	ON	OFF	OFF	ON
21	400L		3 = 800L		OFF	OFF	ON	OFF	ON
22	500L	No Bonus			ON	OFF	ON	OFF	ON
23	500L		3 = 1000L		OFF	ON	ON	OFF	ON
24	500L			5 = 2000L	ON	ON	ON	OFF	ON
25	600L	No Bonus			OFF	OFF	OFF	ON	ON
26	600L		3 = 1200L		ON	OFF	OFF	ON	ON
27	600L			4 = 2000L	OFF	ON	OFF	ON	ON
28	800L	No Bonus			ON	ON	OFF	ON	ON
29	800L		2 = 1000L		OFF	OFF	ON	ON	ON
30	1000L	No Bonus			ON	OFF	ON	ON	ON
31	1000L		2 = 1500L		OFF	ON	ON	ON	ON
32	Free Play				ON	ON	ON	ON	ON

6.1.6. PRICE OF PLAY SETTINGS - PORTUGAL

	Price	Bonus			DIL Switch 1				
					Switch 1	Switch 2	Switch 3	Switch 4	Switch 5
1	50Esc	No Bonus			OFF	OFF	OFF	OFF	OFF
2	50Esc			5 = 200Esc	ON	OFF	OFF	OFF	OFF
3	50Esc		3=100Esc		OFF	ON	OFF	OFF	OFF
4	100Esc	No Bonus			ON	ON	OFF	OFF	OFF
5	100Esc			5 = 400Esc	OFF	OFF	ON	OFF	OFF
6	100Esc		3 = 200Esc		ON	OFF	ON	OFF	OFF
7	150Esc	No Bonus			OFF	ON	ON	OFF	OFF
8	150Esc			3 = 400Esc	ON	ON	ON	OFF	OFF
9	200Esc	No Bonus			OFF	OFF	OFF	ON	OFF
10	200Esc			6 = 1000Esc	ON	OFF	OFF	ON	OFF
11	200Esc		4 = 600Esc		OFF	ON	OFF	ON	OFF
12	250 Esc	No Bonus			ON	ON	OFF	ON	OFF
13	250 Esc		3 = 500Esc		OFF	OFF	ON	ON	OFF
14	300 Esc	No Bonus			ON	OFF	ON	ON	OFF
15	300 Esc			4 = 1000Esc	OFF	ON	ON	ON	OFF
16	400 Esc	No Bonus			ON	ON	ON	ON	OFF
17	400 Esc			3 = 1000Esc	OFF	OFF	OFF	OFF	ON
32	Free Play				ON	ON	ON	ON	ON

6.1.7. PRICE OF PLAY SETTINGS - NETHERLANDS

	Price	Bonus			DIL Switch 1				
					Switch 1	Switch 2	Switch 3	Switch 4	Switch 5
1	1G	No Bonus			OFF	OFF	OFF	OFF	OFF
2	1G		2.5NLG = 2		ON	OFF	OFF	OFF	OFF
3	2G	No Bonus			OFF	ON	OFF	OFF	OFF
4	2G		5NLG = 3		ON	ON	OFF	OFF	OFF
5	3G	No Bonus			OFF	OFF	ON	OFF	OFF
6	3G		5NLG = 2		ON	OFF	ON	OFF	OFF
7	4G	No Bonus			OFF	ON	ON	OFF	OFF
8	4G		10NLG = 3		ON	ON	ON	OFF	OFF
9	5G	No Bonus			OFF	OFF	OFF	ON	OFF
10	5G		10NLG = 3		ON	OFF	OFF	ON	OFF
11	6G	No Bonus			OFF	ON	OFF	ON	OFF
12	6G		15NLG = 3		ON	ON	OFF	ON	OFF
13	8G	No Bonus			OFF	OFF	ON	ON	OFF
14	8G		20NLG = 3		ON	OFF	ON	ON	OFF
15	10G	No Bonus			OFF	ON	ON	ON	OFF
16	10G		20NLG = 3		ON	ON	ON	ON	OFF
17	15G		30NLG = 3		OFF	OFF	OFF	OFF	ON
18	15G	No Bonus			ON	OFF	OFF	OFF	ON
19	20G	No Bonus			OFF	ON	OFF	OFF	ON
32	Free Play				ON	ON	ON	ON	ON

6.1.8. PRICE OF PLAY SETTINGS - SPAIN

	Price	Bonus			DIL Switch 1				
					Switch 1	Switch 2	Switch 3	Switch 4	Switch 5
1	25Pta	No Bonus			OFF	OFF	OFF	OFF	OFF
2	25Pta			5=100Pta	ON	OFF	OFF	OFF	OFF
3	25Pta		3=50Pta		OFF	ON	OFF	OFF	OFF
4	50Pta	No Bonus			ON	ON	OFF	OFF	OFF
5	50Pta			3=100Pta	OFF	OFF	ON	OFF	OFF
6	50Pta		4=150Pta		ON	OFF	ON	OFF	OFF
7	75Pta	No Bonus			OFF	ON	ON	OFF	OFF
8	75Pta			3=200Pta	ON	ON	ON	OFF	OFF
9	75Pta		3=200Pta		OFF	OFF	OFF	ON	OFF
10	100Pta	No Bonus			ON	OFF	OFF	ON	OFF
11	100Pta			4=300Pta	OFF	ON	OFF	ON	OFF
12	100Pta		3=200Pta		ON	ON	OFF	ON	OFF
13	200Pta	No Bonus			OFF	OFF	ON	ON	OFF
14	200Pta			3=500Pta	ON	OFF	ON	ON	OFF
15	200Pta		3=400Pta		OFF	ON	ON	ON	OFF
16	300Pta	No Bonus			ON	ON	ON	ON	OFF
17	300Pta			2=500Pta	OFF	OFF	OFF	OFF	ON
18	300Pta		3=600Pta		ON	OFF	OFF	OFF	ON
19	400Pta	No Bonus			OFF	ON	OFF	OFF	ON
20	400Pta			3=1000Pta	ON	ON	OFF	OFF	ON
21	400Pta		3=800Pta		OFF	OFF	ON	OFF	ON
22	500Pta	No Bonus			ON	OFF	ON	OFF	ON
23	500Pta			3=1000Pta	OFF	ON	ON	OFF	ON
24	500Pta		2=800Pta		ON	ON	ON	OFF	ON
25	600Pta	No Bonus			OFF	OFF	OFF	ON	ON
26	600Pta			3=1200Pta	ON	OFF	OFF	ON	ON
27	600Pta		2=1000Pta		OFF	ON	OFF	ON	ON
28	800Pta	No Bonus			ON	ON	OFF	ON	ON
29	800Pta			2=1000Pta	OFF	OFF	ON	ON	ON
30	1000Pta	No Bonus			ON	OFF	ON	ON	ON
31	1000Pta			2=1500Pta	OFF	ON	ON	ON	ON
32	Free Play				ON	ON	ON	ON	ON

7. DESIGN RELATED PARTS

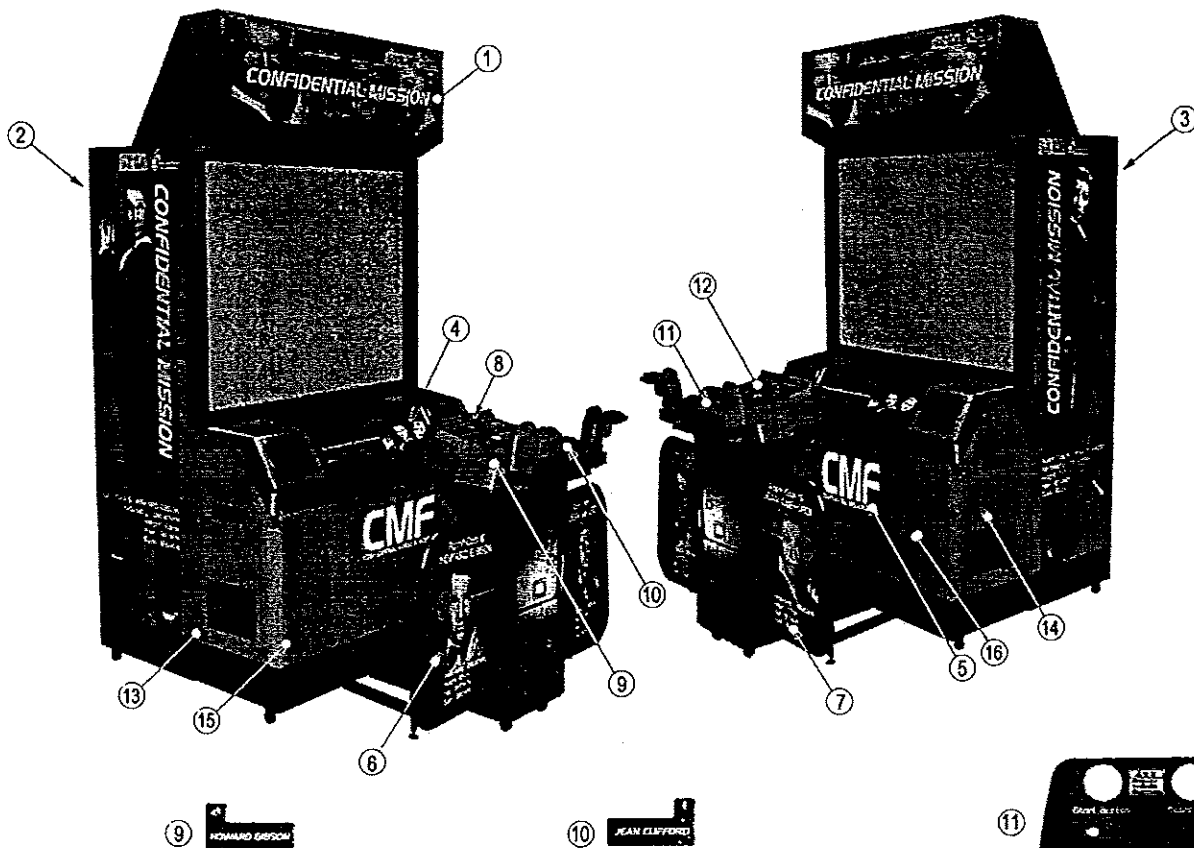

	Part No.	Description
1	SPY-0522UK	BILLBOARD PLATE
2	SPY-0511	STICKER PTV SIDE L
3	SPY-0512	STICKER PTV SIDE R
4	SPY-1062UK	STICKER LID UPPER
5	SPY-1072UK	STICKER LID LOWER
6	SPY-1151UK	GUARD PLATE L
7	SPY-1161UK	GUARD PLATE R
8	SPY-2001-B	STICKER CTRL PNL TOP SPY DX
9	SPY-2001-C	STICKER LEFT SPY DX
10	SPY-2001-D	STICKER RIGHT SPY DX
11	SPY-2001-E	BUTTON SHEET SPY DX
12	SPY-2002UK	INST PLATE SPY DX MULTI
13	SPY-1002-BUK	STICKER CABI SIDE L SPY
14	SPY-1002-CUK	STICKER CABI SIDE R SPY
15	SPY-1002-DUK	STICKER CABI L SPY
16	SPY-1002-EUK	STICKER CABI R SPY

8. PARTS LIST

8.1. SPY-0000UK TOP ASSY SPY DX

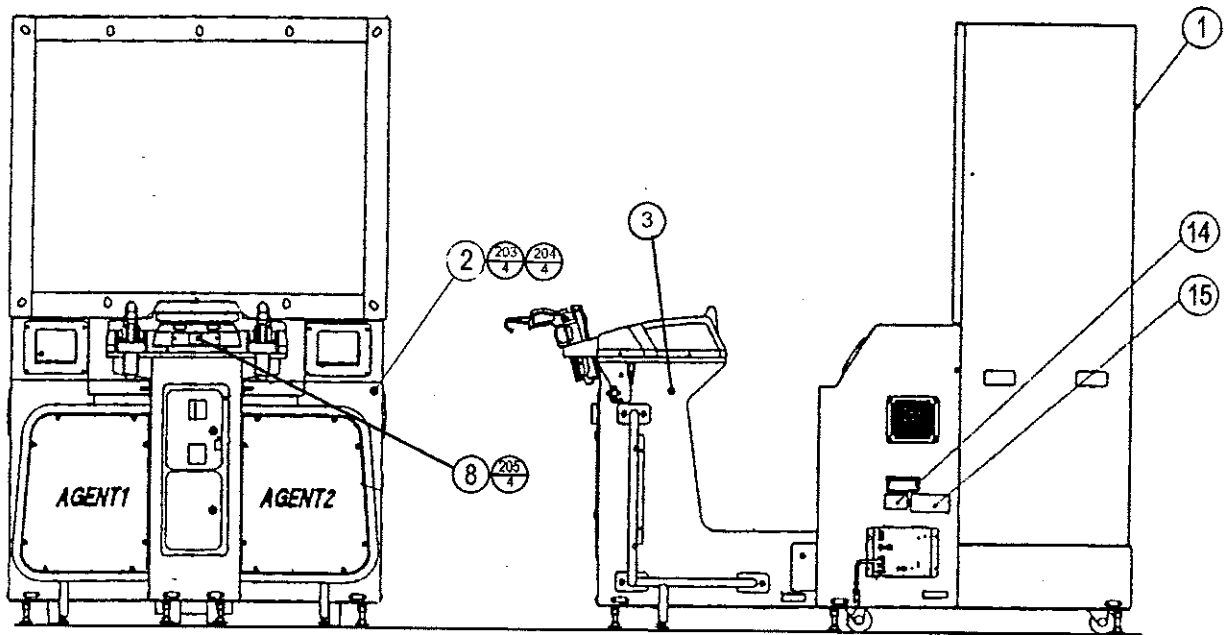

Indent #	Part No.	Description	Component Ref	Qty /assy
1	SPY-0500UK	ASSY PTV		1
2	SPY-1000UK	ASSY PTV CABI DX		1
3	SPY-1100UK	ASSY CONTROLLER CABINET		1
8	HOD-2003	DENOMI PLATE		1
9	SGM-4346	POLY COVER 1200X1200X130		1
10	SGM-4426	POLY COVER 800X750X900		1
14	421-7987-SPY-DX	STICKER ELEC SPEC SPY DX	NEXT TO AC UNIT	1
15	421-7988-91UK	STICKER SERIAL NUMBER UK	NEAR AC,CCT	2
16	LB1102	STICKER DANGEROUS VOLTAGE	ON MAIN LID	1
19	421-7020UK	STICKER CAUTION FORK		2
23	SPY-INST-DX	ASSY INST KIT SPY DX		1
24	PK0180	PALLET CABI HOD DELUXE		1
25	PK0266	SLEEVE CTRL CABI SPY DX		1
26	PK0178	PALLET GUN CABI		1
27	PK0267	SLEEVE GUN CABI SPY DX		1
28	PK0117	PALLET PTV TOSH ZMB		1
29	PK0269	SLEEVE PTV SPY		1
30	LB1046	LABEL TESTED FOR ELEC. S		1
203	000-T00530-0B	M5X30 MSCR TH BLK	(2)-4	4
204	068-552016-0B	M5 WSHR 20OD FLT BLK	(2)-4	4
205	000-T00416-0C	M4X16 MSCR TH CRM	(8)-4	4

8.2. SPY-0500UK ASSY PTV

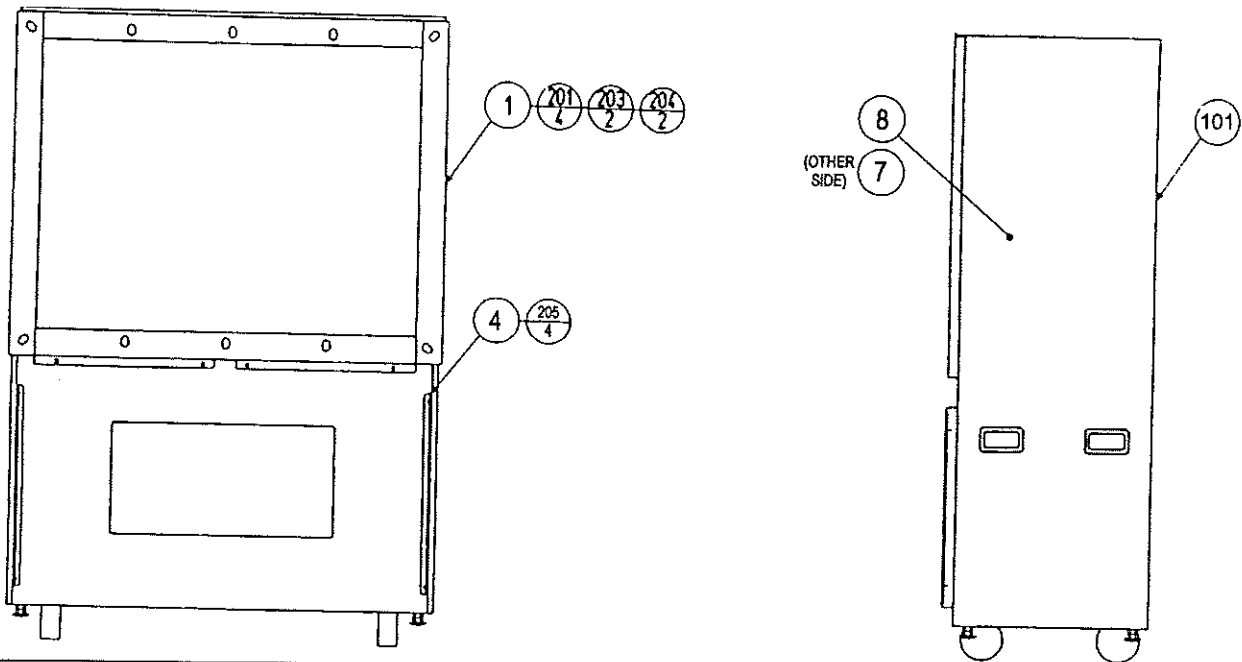

Indent #	Part No.	Description	Component Ref	Qty /assy
1	SPY-0530UK	ASSY MASK		1
4	HOD-1101	PTV HOLDER		2
7	SPY-0511	STICKER PTV SIDE L		1
8	SPY-0512	STICKER PTV SIDE R		1
101	200-5788-31	PROJECTION DSPL T 50TYPE		1
201	000-T00520-0B	M5X20 MSCR TH BLK	(1)-4	4
203	000-T00525-0B	M5X25 MSCR TH BLK	(1)-2	2
204	068-552016-0B	M5 WSHR 20OD FLT BLK	(1)-2	2
205	000-P00516-W	M5X16 MSCR PAN W/FS PAS	(4)-4	4
206	000-F00414	M4X14 MSCR CSK PAS	(1)-4	4
301	SPY-60003	WIRE HARN LED EXT 1		1

8.3. SPY-0520UK ASSY BILLBOARD DX

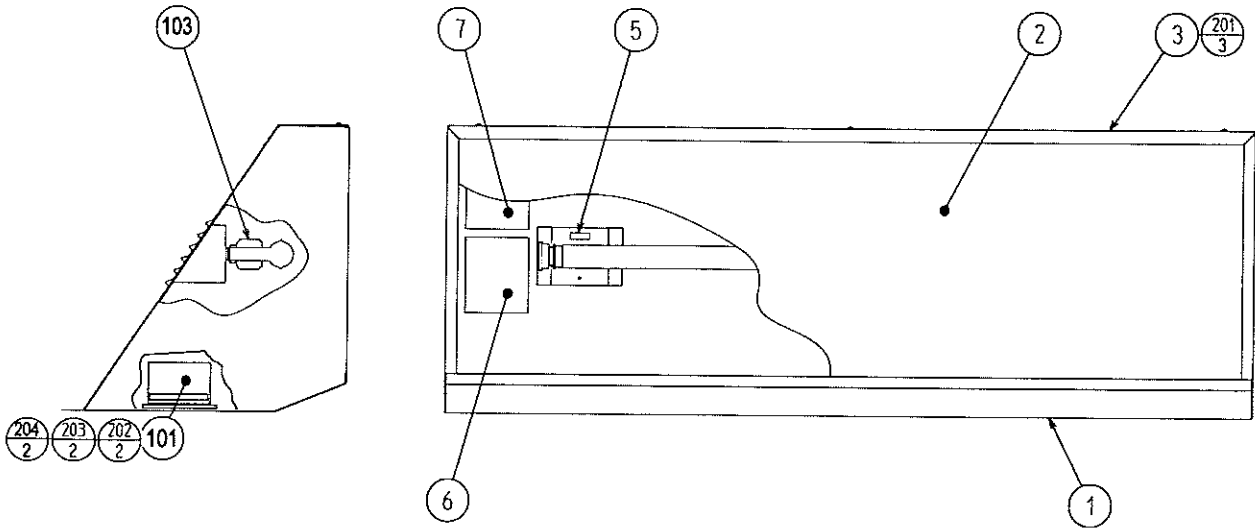

Indent #	Part No.	Description	Component Ref	Qty /assy
1	SPY-0521UK	BILLBOARD BOX		1
2	SPY-0522UK	BILLBOARD PLATE		1
3	SPY-0523	BILLBOARD SASH		1
5	421-7501-16	STICKER 110V 30W		1
6	LB1102	STICKER DANGEROUS VOLTAGE		1
7	LB1104	STICKER CAUTION, HOT SUR		1
101	390-5695-30-AUK	FL TRAY 100V 30W		1
103	LT1014	TUBE FL 30W 36" DIA25mm		1
201	000-T00412-0B	M4X12 MSCR TH BLK	(3)-3	3
202	050-F00400	M4 NUT FLG SER PAS	(101)-2,EARTH	3
203	068-441616	M4 WSHR 16OD FLT PAS	(101)-2	2
204	000-P00412	M4X12 MSCR PAN PAS	(101)-2,TERRY CLIPS	2
301	NCR-60420UK	WIRE HARN FL		1

8.4. SPY-0530UK ASSY MASK

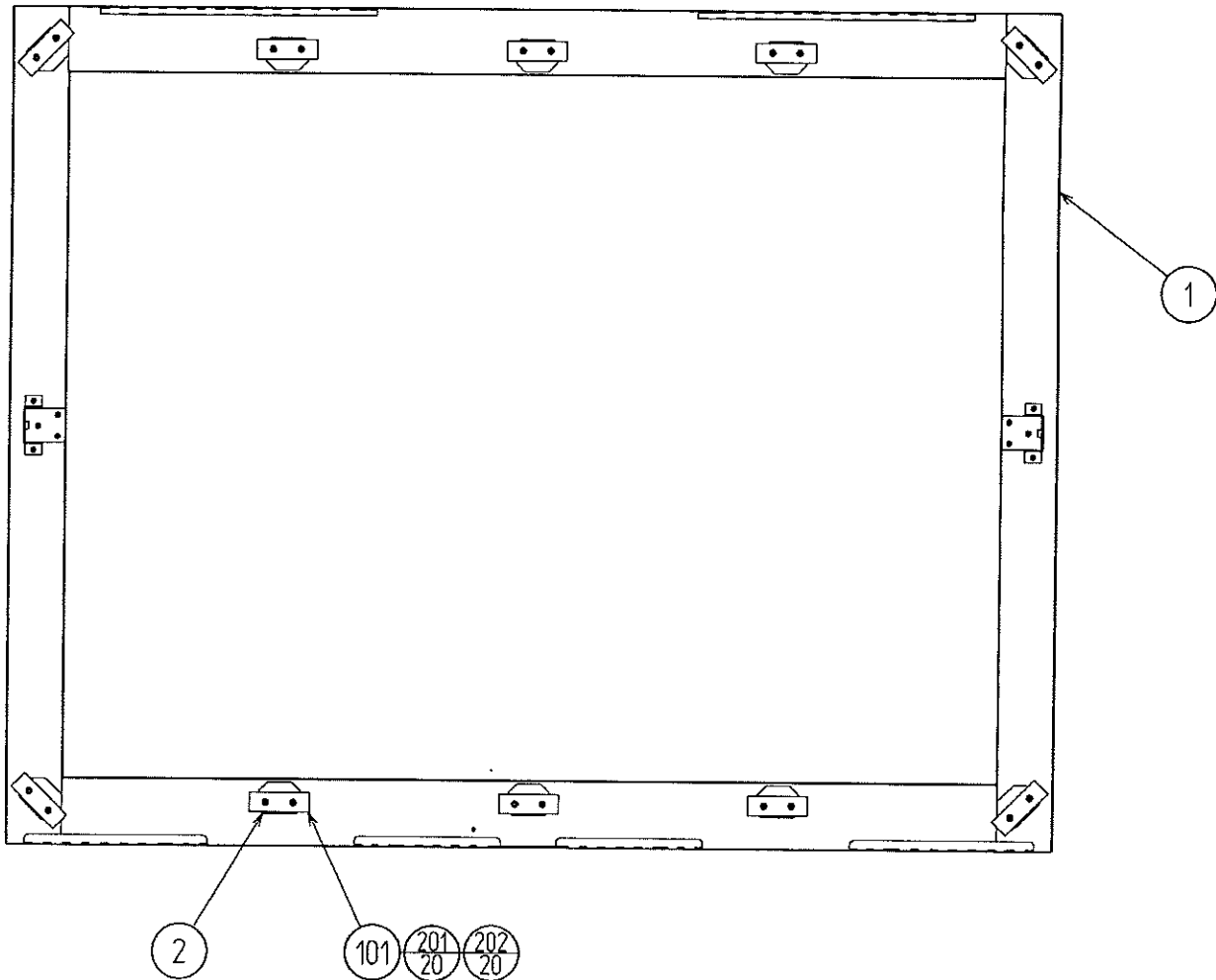

Indent #	Part No.	Description	Component Ref	Qty /assy
1	HOD-1151	MASK BASE		1
2	JPT-1082	IR COVER		10
101	838-13145-02	LED BD GUN SENSE HOD		10
201	050-U00300	M3 NUT NYLOK PAS	(101)-20	20
202	068-330808-PN	M3 WSHR 8OD FLT NYLON	(101)-20	20
203	050-F00400	M4 NUT FLG SER PAS	EARTH-1	1
301	SPY-60024	WIRE HARN MASK SHORT		7
302	SPY-60025	WIRE HARN MASK LONG		2
303	SPY-60026	WIRE HARN MASK INTO		1
304	600-9120-44K	WIRE HARN EARTH 1200mm	MASK TO AC BRKT	1

8.5. SPY-1000UK ASSY PTV CABI DX

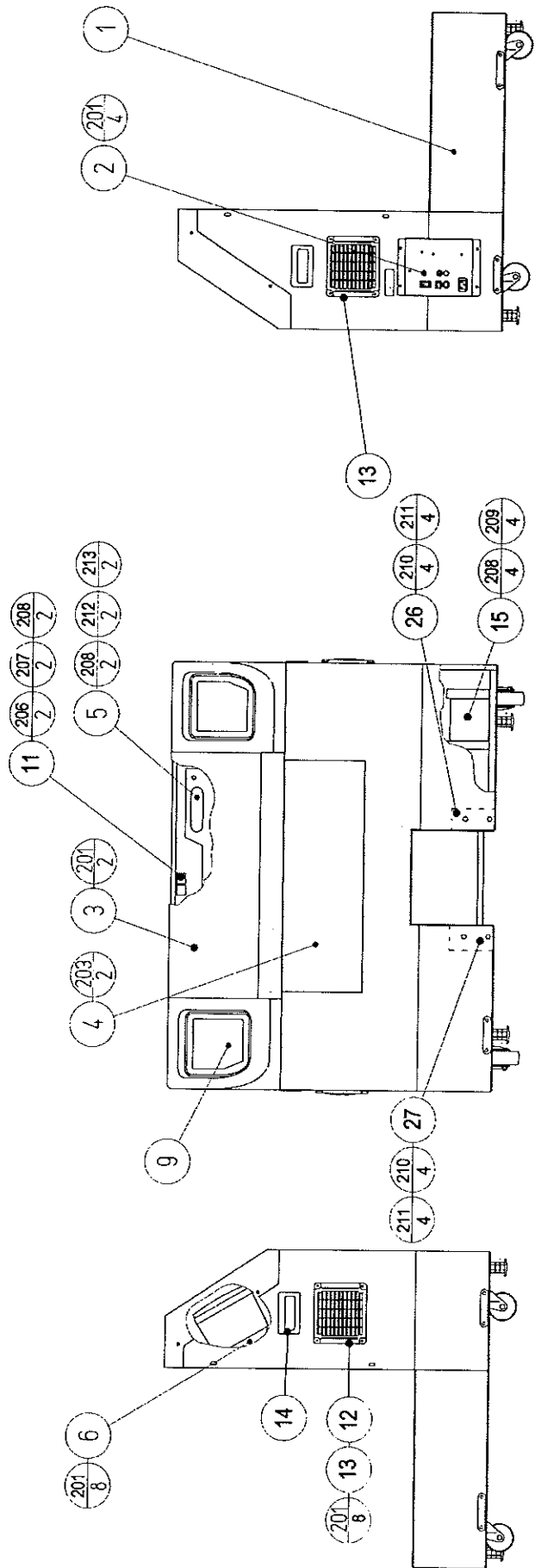

Indent #	Part No.	Description	Component Ref	Qty /assy
1	SPY-1002UK	PTV CABINET		1
2	HOD-1020UK	ASSY AC UNIT UK		1
3	SPY-1060UK	ASSY LID UPPER		1
4	SPY-1070UK	ASSY LID LOWER		1
5	SPY-4000UK	ASSY MAIN BD DX		1
6	HOD-1070UK	ASSY SPEAKER UK		2
9	SPY-1010UK	SPEAKER COVER		2
11	HOD-1003	LOCKING BRKT HOD		1
12	HOD-1530UK	FAN UNIT UK		1
13	253-5460-01	AIR VENT BLACK		2
14	253-5396-91	CABINET HANDLE		2
15	SPY-4100UK	ASSY PWR SPLY		1
16	SPY-1002-BUK	STICKER CABI SIDE L SPY	See DESIGN RELATED PARTS, section 0	1
17	SPY-1002-CUK	STICKER CABI SIDE R SPY		1
18	SPY-1002-DUK	STICKER CABI L SPY		1
19	SPY-1002-EUK	STICKER CABI R SPY		1
20	SPY-1002-FUK	STICKER CABI UP L SPY		1
21	SPY-1002-GUK	STICKER CABI UP R SPY		1
26	HOD-1007	JOINT BRKT R		1
27	HOD-1008	JOINT BRKT L		1
101	280-A01264-WX	ROUTER TWIST D12 SO6.4		5
102	280-A00964-WX	ROUTER TWIST D09 SO6.4		4
201	000-T00420-0B	M4X20 MSCR TH BLK	(2)-4,(3)-2,(13)-8,(6)-8	22
203	000-P00420-W	M4X20 MSCR PAN W/FS PAS	(4)-2	2
206	000-P00425-W	M4X25 MSCR PAN W/FS PAS	(11)-2	2
207	050-F00400	M4 NUT FLG SER PAS	(11)-2	2
208	068-441616-0B	M4 WSHR 16OD FLT BLK	(11)-2,(15)-4,(5)-2	8
209	000-P00430-W	M4X30 MSCR PAN W/FS PAS	(15)-4	4
210	030-000840-SB	M8X40 BLT W/S BLK	(26,27)-4	8
211	068-852216-0B	M8 WSHR 22OD FLT BLK	(26,27)-4	4
212	032-000530	M5X30 BLT WING PAS	(5)-2	2
213	068-551616	M5 WSHR 16OD FLT PAS	(5)-2	2
301	SPY-60011UK	WIRE HARN TOWER EXT 1		1
302	SPY-60012UK	WIRE HARN START EXT 1		1
303	SPY-60013UK	WIRE HARN RECEIVER EXT		1

8.6. SPY-1060UK ASSY LID UPPER

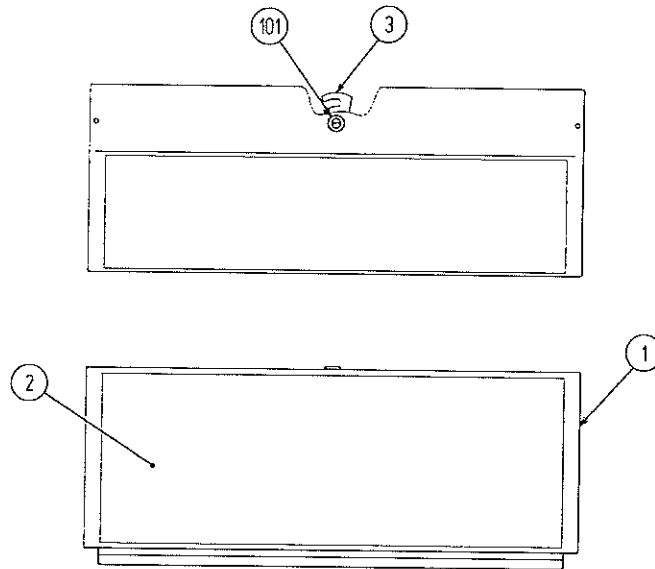

Indent #	Part No.	Description	Component Ref	Qty /assy
1	HOD-1051-A	FRONT LID U BLANK		1
2	SPY-1062UK	STICKER LID UPPER		1
3	TH1015UK	LOCKING TONGUE U		1
101	220-5575UK	LOCK		1

8.7. SPY-1070UK ASSY LID LOWER

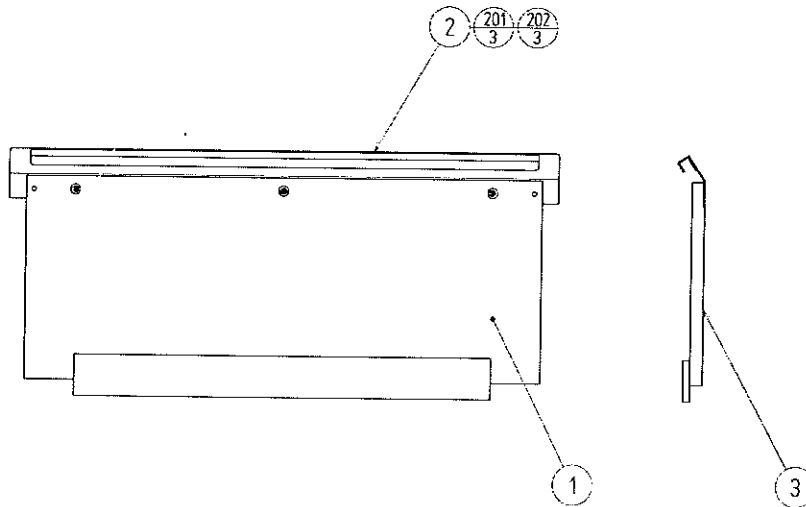

Indent #	Part No.	Description	Component Ref	Qty /assy
1	HOD-1061-AUK	FRONT LID L BLANK		1
2	HOD-1062-A	FRONT LID BRKT BLANK		1
3	SPY-1072UK	STICKER LID LOWER		1
201	050-F00400	M4 NUT FLG SER PAS	(2)-3	3
202	060-F00400-0B	M4 WSHR FORM A FLT BLK	(2)-3	3

8.8. SPY-1100UK ASSY CONTROLLER CABINET

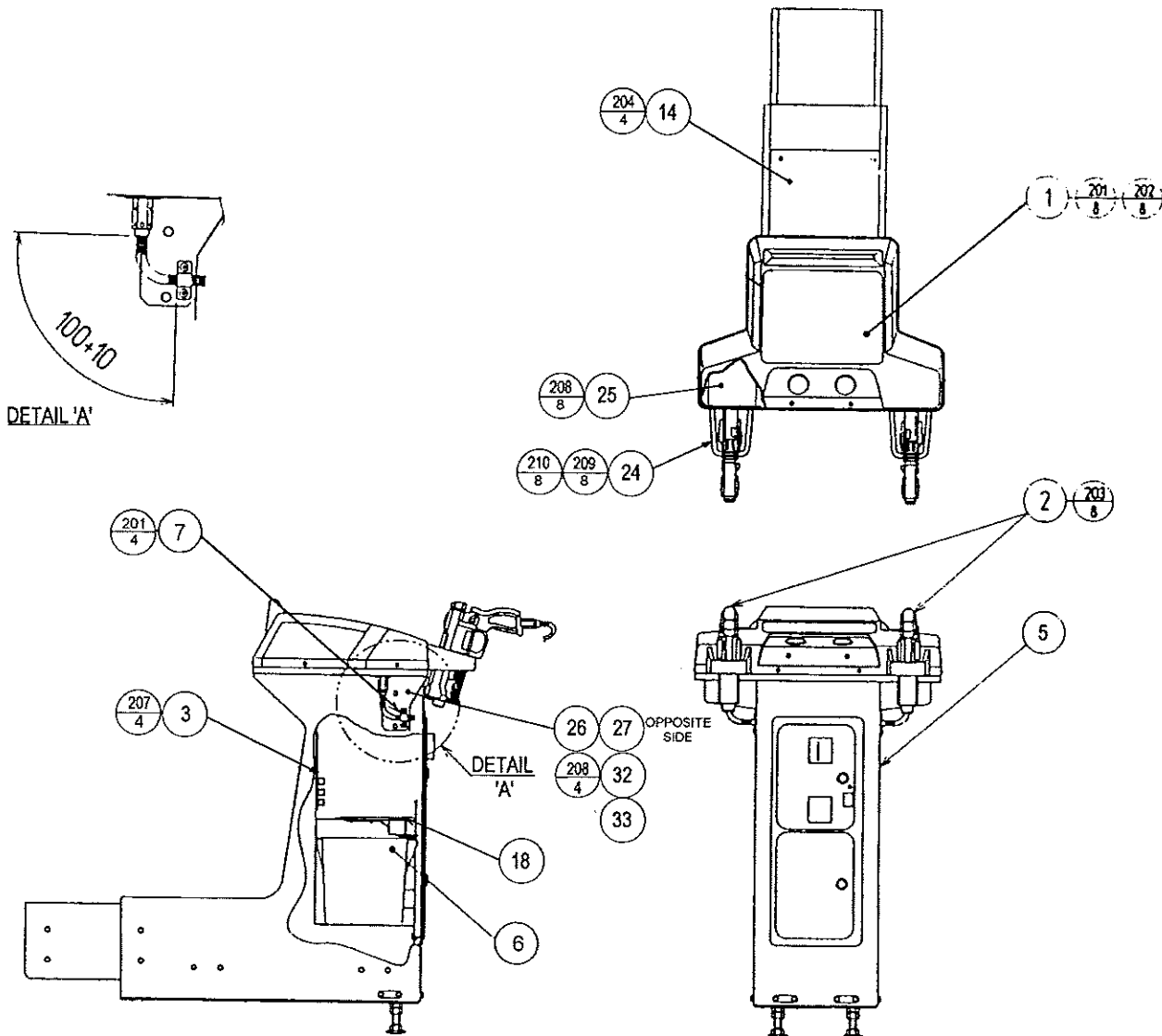

#	Part No.	Description	Component Ref	Qty
1	SPY-2000UK	ASSY CTRL PANEL DX		1
2	SPY-2100	CONTROL UNIT DX		2
3	VTS-HOD-D	VTS BOARD HOD		1
5	HOD-1302UK	GUN HOLDER CABI		1
6	253-5366	CASH BOX		1
7	JPT-3101	TUBE CLAMP		2
14	HOD-1304	JOINT PART LID		1
18	DUT-0302UK	COIN PATH PLATE		1
24	HOD-1019UK	GUN HOLDER UK		2
25	SPY-1106	HOLDER BRKT		2
26	HOD-1307-A	SIDE BRKT L BLANK		1
27	HOD-1308-A	SIDE BRKT R BLANK		1
30	SPY-1150UK	ASSY FENCE L	BUBBLE WRAP SEPARATELY	1
31	SPY-1160UK	ASSY FENCE R	BUBBLE WRAP SEPARATELY	1
32	CPT-1021-B	PROTECT SHEET L	(26)-1	1
33	CPT-1022-B	PROTECT SHEET R	(27)-1	1
201	000-T00416-0B	M4X16 MSCR TH BLK	(1)-8,(7)-4	12
202	068-441616-0B	M4 WSHR 16OD FLT BLK	(1)-8	8
203	000-T00430-0C	M4X30 MSCR TH CRM	(2)-8	8
204	000-T00440-0B	M4X40 MSCR TH BLK	(14)-4	4

207	000-P00420-W	M4X20 MSCR PAN W/FS PAS	(3)-4,(18)-5	9
208	030-000630-SB	M6X30 BLT W/S BLK	(25)-8,(26,27)-4	12
209	030-000616-SB	M6X16 BLT W/S BLK	(24)-8	8
210	060-F00600-0B	M6 WSHR FORM A FLT BLK	(24)-8	8
211	000-P00408-W	M4X8 MSCR PAN W/FS PAS	EARTHS-2	2
301	SPY-60014UK	WIRE HARN TOWER EXT 2		1
302	SPY-60015	WIRE HARN START EXT 2		1
303	SPY-60016	WIRE HARN EXT 2		1
304	600-9220-44K	WIRE HARN EARTH 2200mm M	LH GUN HOLDER TO AC BRKT	1
305	600-9040-44K	WIRE HARN EARTH 400mm M4	LH GUN HOLDER TO RH GUN HOLDER	1

8.9. SPY-1150UK ASSY FENCE L

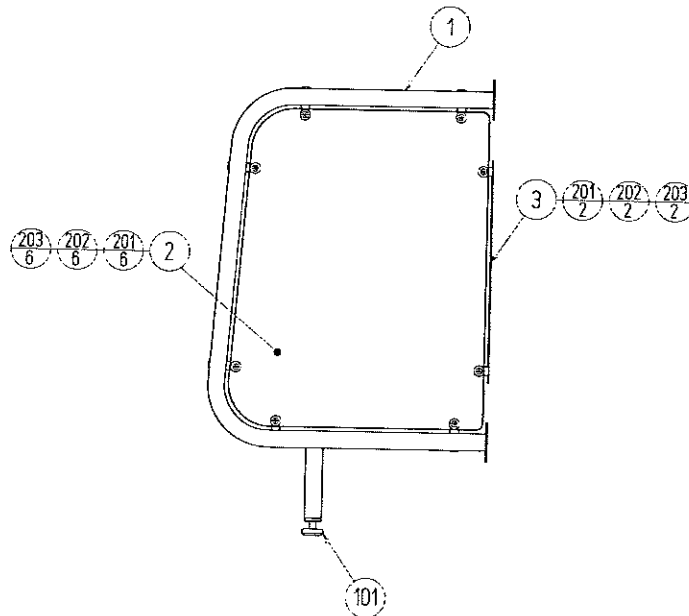

201: TIGHTEN TO 0.7nM

Indent #	Part No.	Description	Component Ref	Qty /assy
1	HOD-1351	PIPE L		1
2	SPY-1151UK	GUARD PLATE L		1
3	HOD-0004UK	PLATE HOLDER		2
101	601-6076-0BUK	LEG ADJUSTER 32MM BLACK		1
201	000-T00412-0B	M4X12 MSCR TH BLK	(2)-6,(3)-2	8
202	068-441616-0B	M4 WSHR 16OD FLT BLK	(2)-6,(3)-2	8
203	050-C00400-3B	M4 NUT DOME TYPE 3 BLK	(2)-6,(3)-3	8

8.10. SPY-1160UK ASSY FENCE R

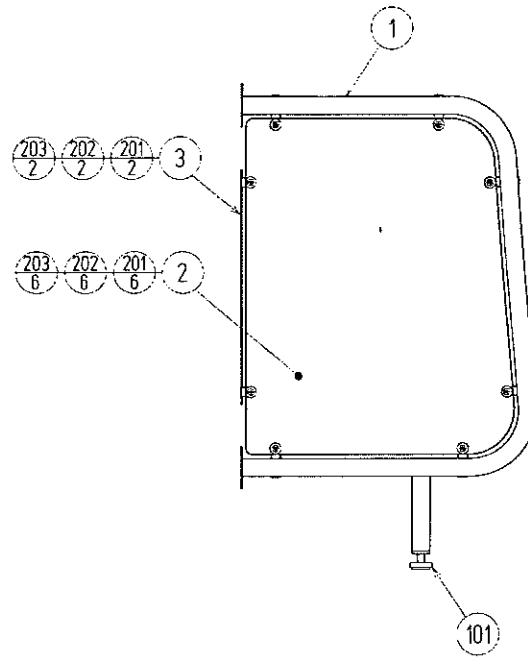

201. TIGHTEN TO 0.7M

Indent #	Part No.	Description	Component Ref	Qty /assy
1	HOD-1361	PIPE R		1
2	SPY-1161UK	GUARD PLATE R		1
3	HOD-0004UK	PLATE HOLDER		2
101	601-6076-OBUK	LEG ADJUSTER 32MM BLACK		1
201	000-T00412-0B	M4X12 MSCR TH BLK	(2)-6,(3)-2	8
202	068-441616-0B	M4 WSHR 16OD FLT BLK	(2)-6,(3)-2	8
203	050-C00400-3B	M4 NUT DOME TYPE 3 BLK	(2)-6,(3)-2	8

8.11. SPY-2000UK ASSY CTRL PANEL DX

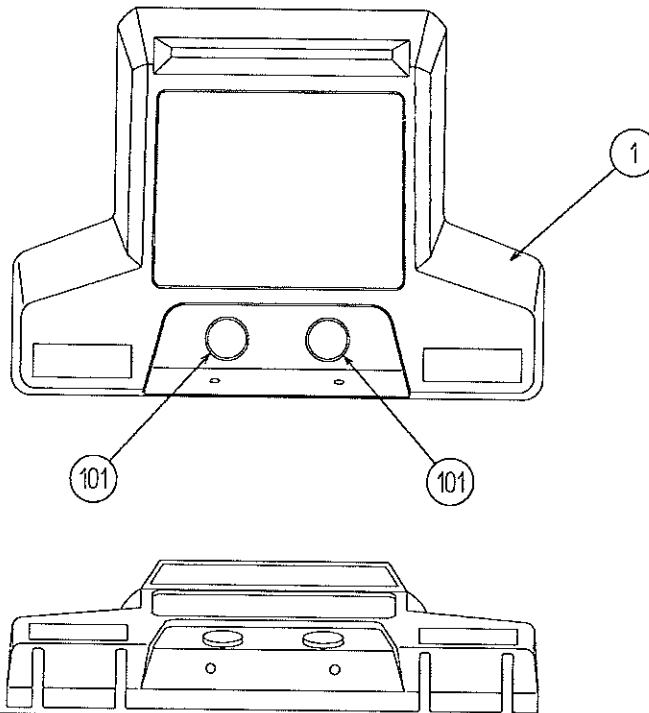

Indent #	Part No.	Description	Component Ref	Qty /assy
1	SPY-2001-A-W	CTRL PNL BLANK W/NUT PLATE		1
3	SPY-2001-B	STICKER CTRL PNL TOP SPY		1
4	SPY-2001-C	STICKER LEFT SPY DX	See DESIGN RELATED PARTS, Section 0	1
5	SPY-2001-D	STICKER RIGHT SPY DX		1
6	SPY-2001-E	BUTTON SHEET SPY DX		1
101	509-5712-01	SW PB W/L 6V YELLOW		2
301	HOD-60020	WIRE HARN CONTROL PANEL		1

8.12. SPY-4000UK ASSY MAIN BD DX

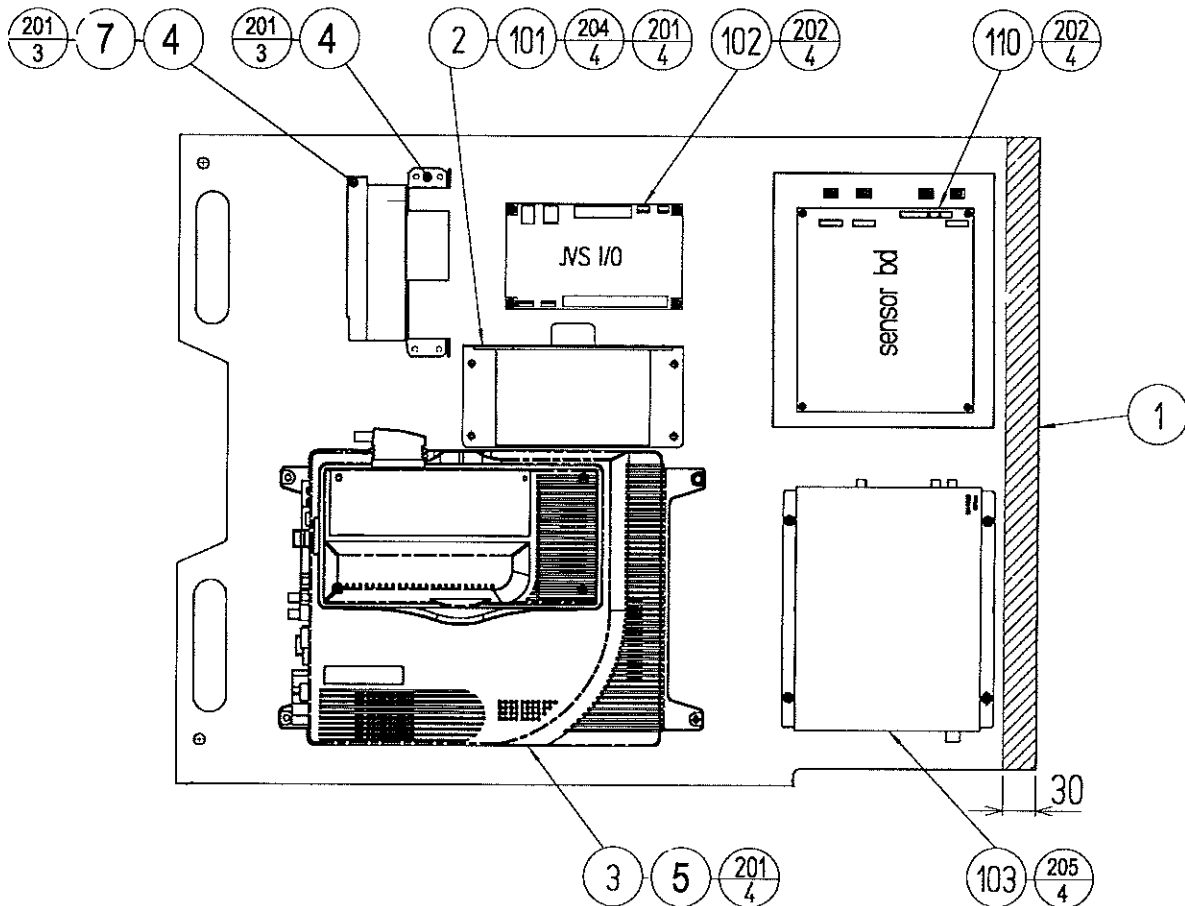

No wiring to be routed in hatched area

Indent #	Part No.	Description	Component Ref	Qty /assy
1	SPY-4001UK	WOODEN BASE MAIN BD DX		1
2	TMB-4003	SW REGU BRKT		1
3	840-0050D-02	ASSY CASE NAO GD SPY EXP		1
4	105-5435	GD DRIVE BRKT STD		1
5	LB1101	STICKER WARNING BATTERY		1
6	610-0617	GD-ROM DRIVE UNIT NAOMI		1
7	610-0625-0001	GD SOFTWARE SPY		1
101	400-5397-01	SW REGU FOR JVS VA		1
102	837-13551-92	I/O CONTROL BD FOR JVS		1
103	838-13616	AUDIO POWER AMP 2CH		1
104	280-A00964-WX	ROUTER TWIST D09 SO6.4 W		7
105	280-A01264-WX	ROUTER TWIST D12 SO6.4 W		6
106	280-A02064-WX	ROUTER TWIST D20 SO6.4 W		6
110	838-13143-08	IC BD GUN SENSE SPY		1
201	000-P00416-W	M4X16 MSCR PAN W/FS PAS	(2)-4,(3)-4,(4)-3	11
202	012-P00325	N4X1" S/TAP PAN PAS	(102)-4,(110)-4	8
204	000-P00408-W	M4X8 MSCR PAN W/FS PAS	(101)-4	4
205	012-P03512-F	N6X1/2" S/TAP FLG PAS	(103)-4	4
206	012-P00410-F	N8X3/8" S/TAP FLG PAS	(6)-4	4
301	SPY-60010UK	WIRE HARN HIGH FRQNCY JU	CN1 ON IC BD GUN SENSE SPY	1
302	600-7159-039	WIRE HARN JVS PWR 039CM		1
303	SPY-60009	WIRE HARN CTRL BD RECIEV		1
304	SPY-60002UK	WIRE HARN AC MAIN BD		1
305	SMB-60013	WIRE HARN SPEAKER L		1

306	SMB-60014	WIRE HARN SPEAKER R		1
307	SPY-60005	WIRE HARN AUDIO L		1
308	SPY-60006	WIRE HARN AUDIO R		1
309	SPY-60007UK	WIRE HARN SW CONTROL		1
310	600-7009-2500	ASSY RGB CA D-SUB 15P 25		1
313	600-7141-100	CABLE JVS TYPE A-B 100CM		1
315	600-7242-250	CABLE SCSI ST-L TYPE1 25		1

8.13. SPY-4100UK ASSY PWR SPLY

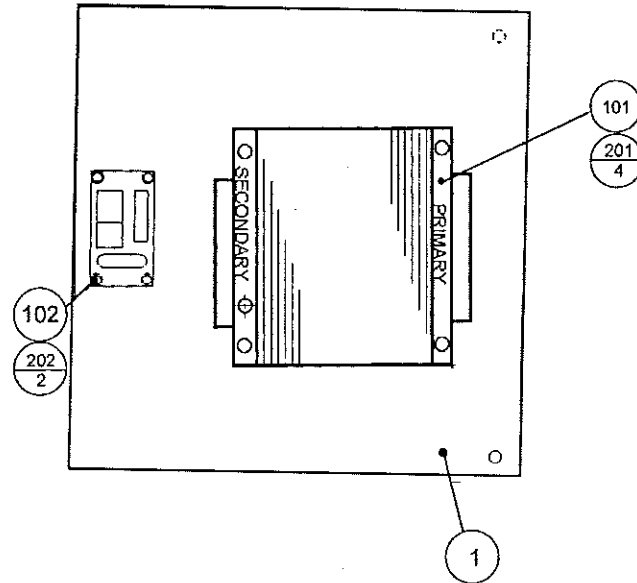

Indent #	Part No.	Description	Component Ref	Qty /assy
1	HOD-4101UK	WOODEN BASE PWR SPLY		1
101	560-5422UK	XFMR NOB		1
102	838-11856CE-02	CONN BD W/FUSE 6.3A CE		1
201	000-P00416-W	M4X16 MSCR PAN W/FS PAS	(XFMR)-4	4
202	012-P00325	N4X1" S/TAP PAN PAS	(CONN BD)-2	2
301	SPY-60004UK	WIRE HARN AC-CONN BD		1

8.14. SPY-INST-DX ASSY INST KIT SPY DX

Ind #	Part No.	Description	Component Reference	Qty
1	SPY-0520UK	ASSY BILLBOARD DX		1
2	HOD-0006	L BRKT		2
22	PK0268	CARTON BOX INST KIT SPY		1
23	SAECE-067	DECLARATION OF CONFORMITY		1
24	SPY-2002UK	INST PLATE SPY DX MULTI		1
101	PK0018	BUBBLE WRAP SMALL X 1M R		0.03
201	030-000850-SB	M8X50 BLT W/S BLK	FENCE L+R-2EA	4
202	030-000830-SB	M8X30 BLT W/S BLK	FENCE L+R-4EA	8
205	000-T00420-0B	M4X20 MSCR TH BLK	FENCE L+R-2EA	4
206	068-441616-0B	M4 WSHR 16OD FLT BLK	FENCE L+R-2EA	4
207	030-000840-SB	M8X40 BLT W/S BLK	(2)-8	8
208	068-852216-0B	M8 WSHR 22OD FLT BLK	(2)-8,FENCE L+R-6EA	24
209	030-000860-0B	M8X60 BLT BLK	F.CABI-4	4
401	420-6620UK	SERVICE MANUAL GD ROM SYS		1
402	OS1019	SELF SEAL BAG 9X12.3/4		2
403	420-6601-01UK	SERVICE MANUAL SPY DX		1
405	390-5160	LAMP WG B TYPE 6V 3W (C2)		1
406	509-5080	SW MICRO TYPE (SS-5GL2)		1
413	514-5078-5000	FUSE 5X20 CERAMIC SB 500		1

8.15. HOD-1020UK ASSY AC UNIT

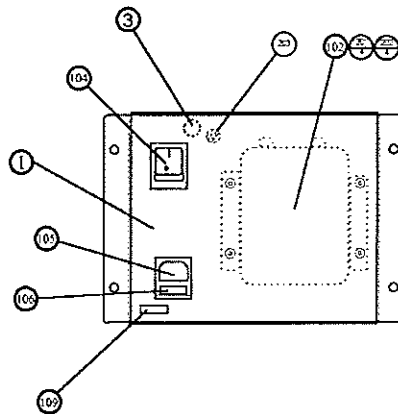

Indent #	Part No.	Description	Component Ref	Qty /assy
1	HOD-1021UK	AC BRKT UK		1
3	LB1096	STICKER PROTECTIVE EARTH	(EARTH STUD)	1
102	EP1379	FILTER EMI 10A ARCOTRONICS		1
104	SW1109	SWITCH ROCKER 250V AC		1
105	EP1302	EURO SOCKET FUSED 10A 250Vac		1
106	514-5078-5000	FUSE 5X20 CERAMIC SB 5000mA		1
107	310-5029-D508	HEAT SHRINK SLEEVING 50.8DIA		0.04
109	421-6595-5000-T	STICKER FUSE 5000mA TYPE T		1
201	FX0399	M3X8 MSCR POSI PAN BZP	(102)-4	4
202	FX0263	M3 WSHR FORM A FLT BZP	(102)-4	4
203	050-F00400	M4 NUT FLG	EARTH STUD	2
301	600-6911-049UK	WIRE HARN AC BRKT (JPT)		1
302	600-7118-002UK	WIRE HARN AC OUT (PRIMARY)		1

8.16. HOD-1070UK ASSY SPEAKER

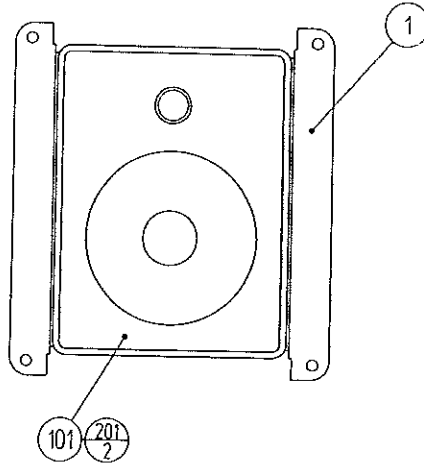

Indent #	Part No.	Description	Component Ref	Qty /assy
1	CPT-1061UK	SPEAKER BRKT UK		1
101	130-5096	ASSY SERVO SPEAKER BOX		1
201	000-P00512-W	M5X12 MSCR POSI PAN W/FS PAS	(101)-2	2
301	HOD-60025	WIRE HARN SPEAKER UNIT		1

8.17. HOD-1530 ASSY FAN UNIT

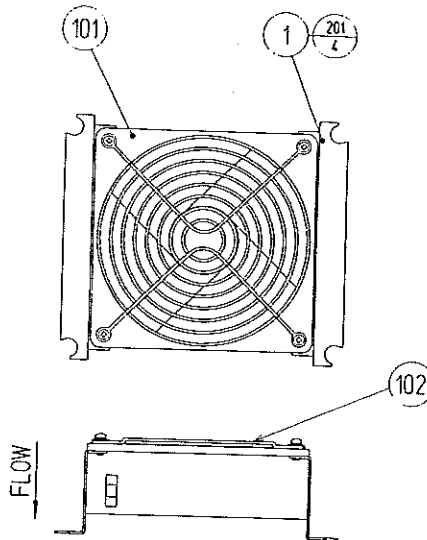

Indent #	Part No.	Description	Component Ref	Qty /assy
1	105-5340-01	FAN BRKT LONG		2
101	260-0011-02	AXIAL FLOW FAN AC100V 50-60Hz		1
102	FN1012	MESH GUARD METAL 120mm FAN		1
201	000-P00312-W	M3X12 MSCR POSI PAN W/FS PAS	(1)-4	4
301	HOD-60211UK	WIRE HARN FAN		1

9. APPENDIX A - ELECTRICAL SCHEMATIC

9.1. WIRE COLOURS

THE WIRE COLOUR CODE IS AS FOLLOWS:

A	PINK
B	SKY BLUE
C	BROWN
D	PURPLE
E	LIGHT GREEN

Wires other than those of any of the colours listed above will be displayed by 2 alphanumeric characters:

1	RED
2	BLUE
3	YELLOW
4	GREEN
5	WHITE
7	ORANGE
8	BLACK
9	GREY

If the right hand side numeral of the code is 0, then the wire will be of a single colour shown by the left hand side numeral (see the list above).

Note 1: If the right hand side alphanumeric is not 0, that particular wire has a spiral colour code. The left hand side character shows the base colour and the right hand side one, the spiral colour.

[Example] 51----- WHITE/RED = WHITE wire with RED stripes

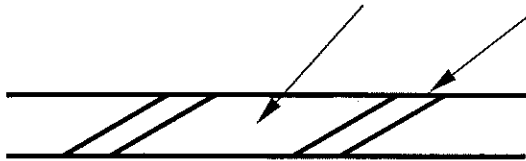

Note 2: The character following the wire colour code indicates the size of the wire.

K:	AWG18, UL1015
L:	AWG20, UL1007
None	AWG22, UL1007

9.2. ELECTRICAL SCHEMATIC

The following pages contain the electrical schematic for this machine.

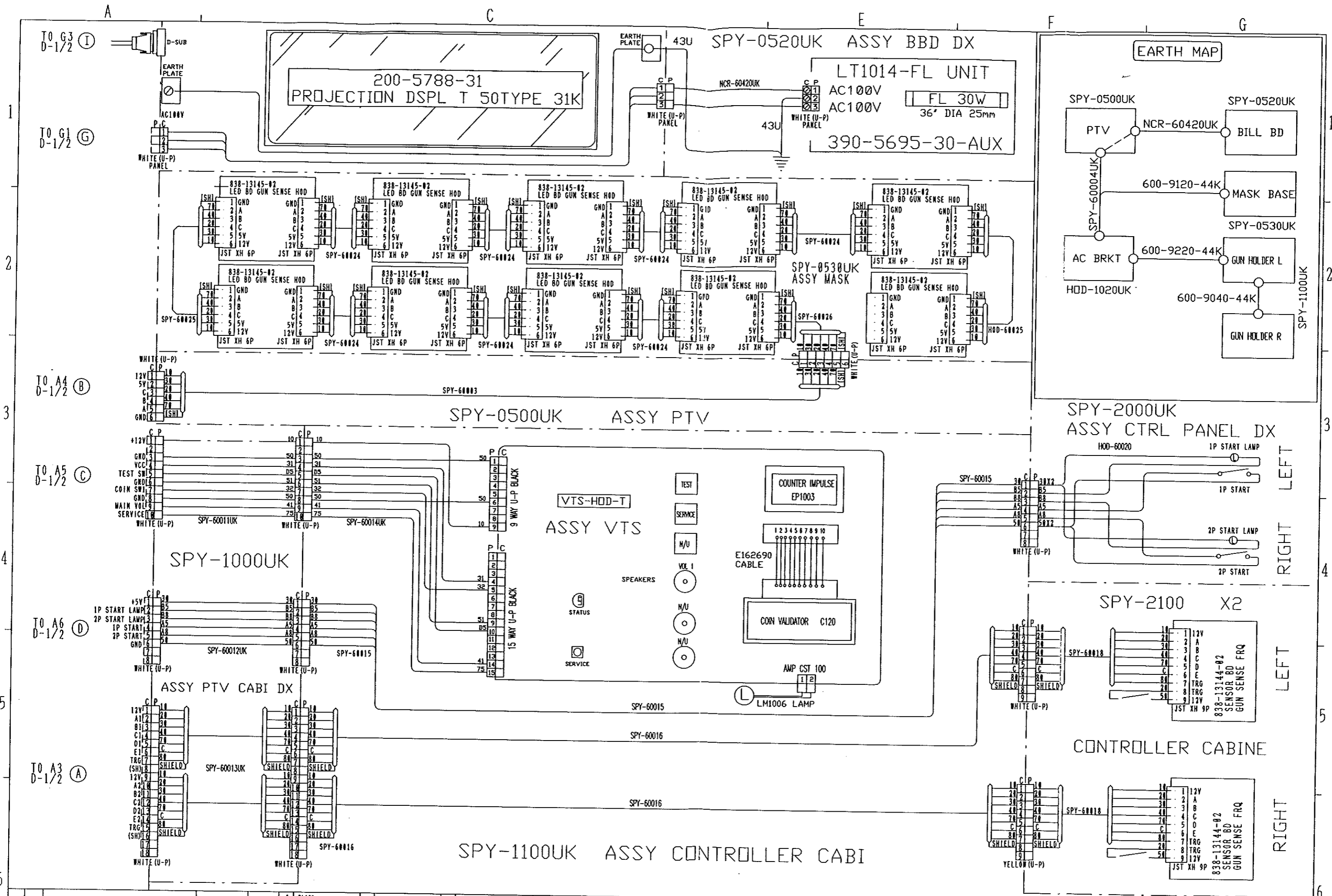

8 BLACK 7 BRANGE 5 WHITE 4 GREEN 3 YELLOW 2 BLUE 1 RED		E LIGHT GREEN D PURPLE C BRANN B SKY BLUE A PINK W GRAY		431 EARTH WIRE U1 ANGIA 011015 U2 ANGIA 011017 ANG22 011017		DRAWN MT 20/11/00		SEGA SEGA ENTERPRISES, LTD. THIS DRAWING WILL IN NO WAY BE COPIED. TO BE TURNED ON DEMAND.		SPY-0000UK TOP ASS'Y		SPY DX UK DESCRIPTION		SCHEM 2/2 DIAGRAM NO.	
--	--	--	--	--	--	-------------------------	--	--	--	-------------------------	--	--------------------------	--	--------------------------	--

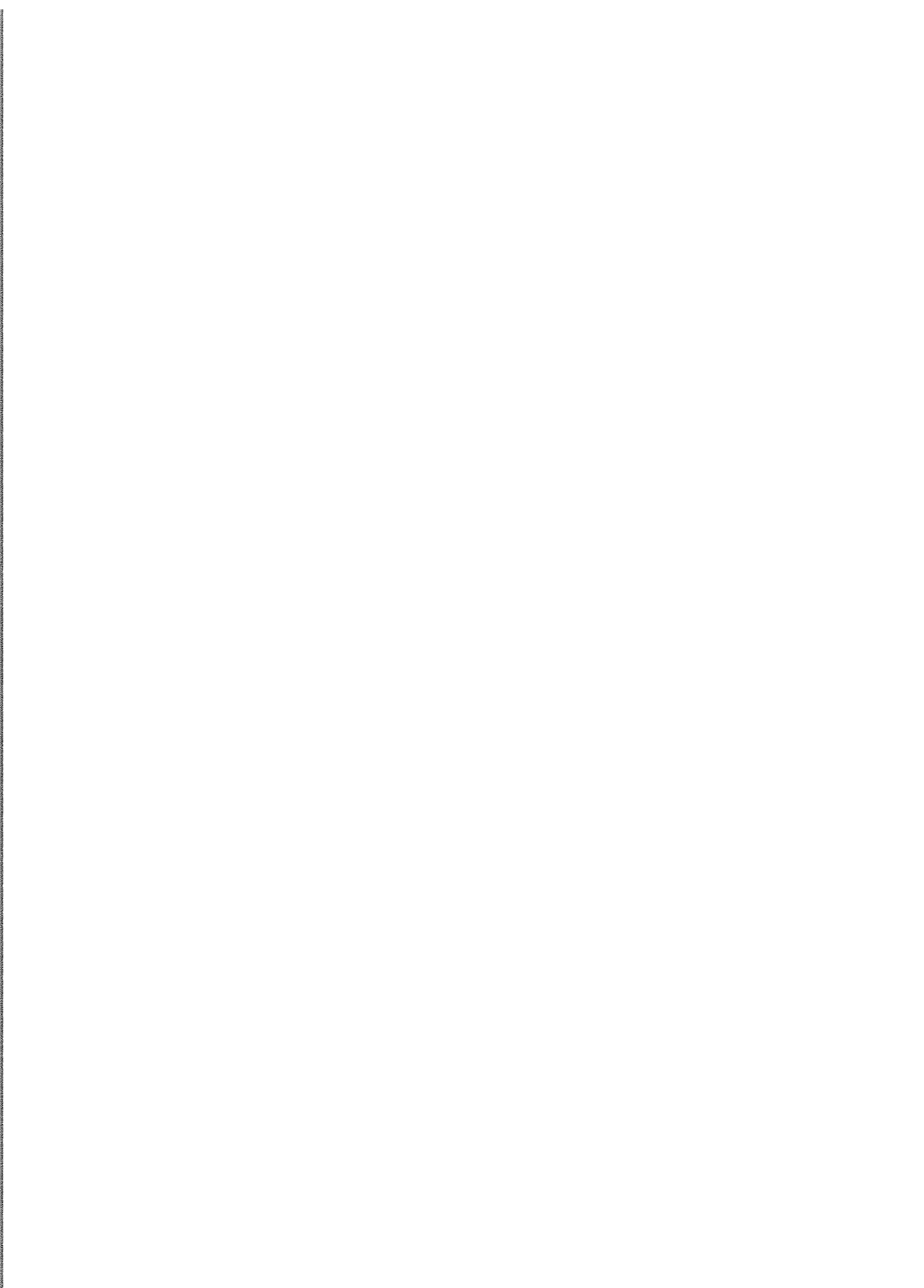
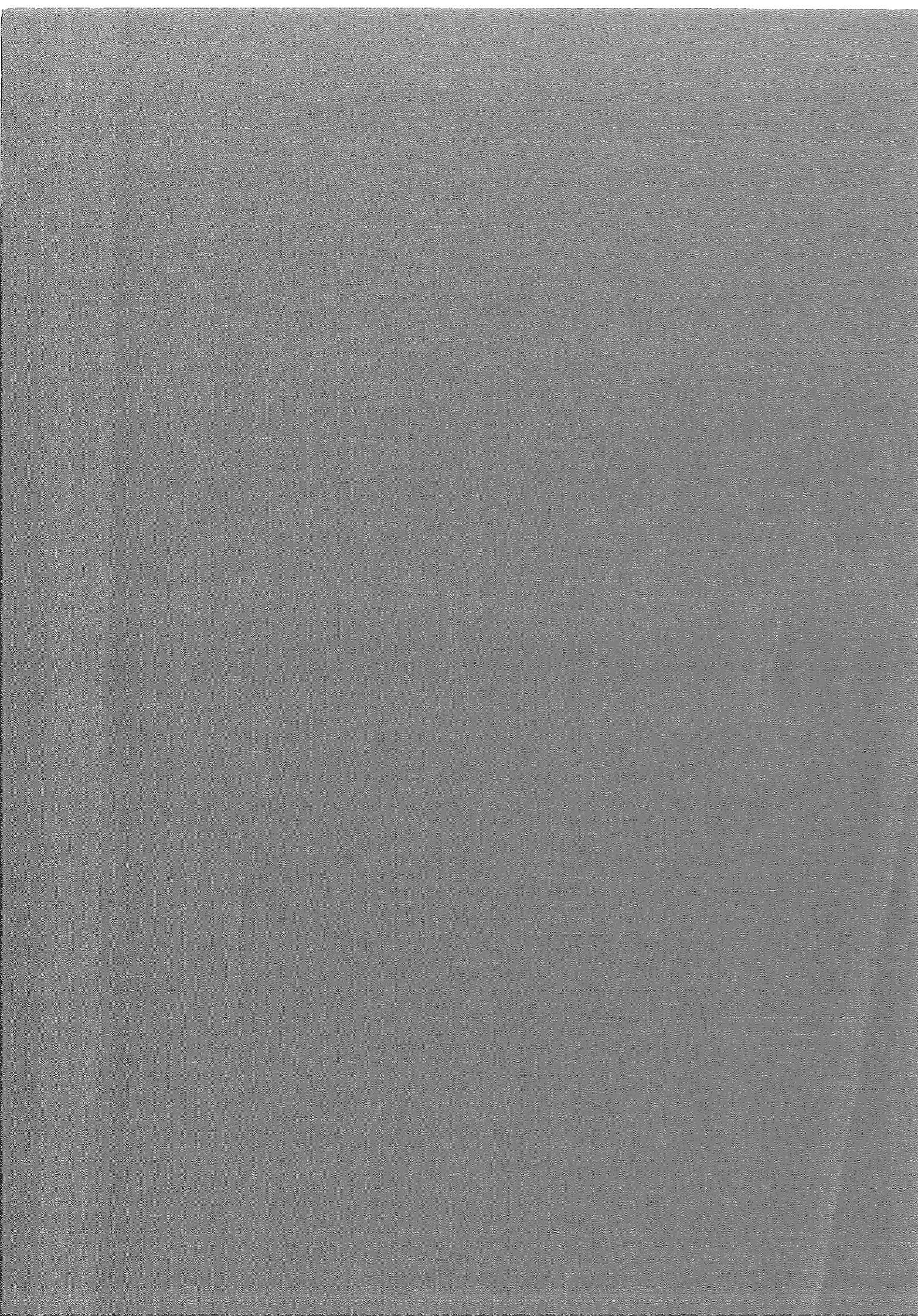

SEGA AMUSEMENTS EUROPE

Unit 2 Industrial Estate
Leigh Close
New Malden
Surrey
KT3 3NL
UK

UK Customers

Tel: +44(0) 20 8336 1222

Fax: +44(0) 20 8336 1715

European Customers

Tel: +44(0) 20 8336 2256

Fax: +44(0) 20 8942 1343

SEGA



© SEGA 2000